

MODEL 737-1 PRINTER

OWNER'S MANUAL

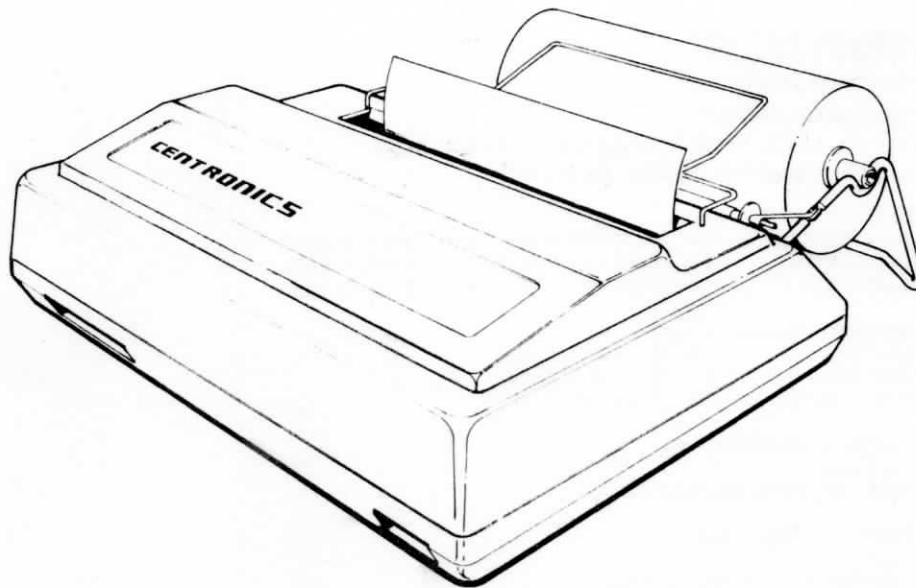

MARCH 1980
Centronics No. 37400781 Rev.-3

CENTRONICS®
data computer corporation
Hudson, New Hampshire 03051
Telephone (603) 883 - 0111

THE INFORMATION CONTAINED HEREIN IS
PROPRIETARY AND IS NOT TO BE RELEASED
OR REPRODUCED WITHOUT WRITTEN PER-
MISSION OF CENTRONICS data computer corp.

SERVICING INFORMATION FOR YOUR PRINTER MAY BE
OBTAINED BY CALLING THE NUMBERS LISTED BELOW.
(ASK FOR FIELD ENGINEERING)

CENTRONICS® data computer corporation

Hudson, New Hampshire 03051

Tel. (603) 883-0111, TWX. (710) 228-6565, TLX. 94-3404

Field Engineering Headquarters - (603) 883-2492

— Regional Sales Offices —

Eastern Region (Mass.): Tel. (617) 935-6150, TWX. 710-348-0343
Central Region (Texas): Tel. (817) 461-5711, TWX. 910-890-4916
Western Region (Calif.): Tel. (714) 979-6650, TWX. 910-595-1925

— Regional Field Engineering Offices —

Eastern Region (Mass.): Tel. (617) 935-8130
Central Region (Texas): Tel. (817) 461-7121
Western Region (Calif.): Tel. (714) 957-1510

Centronics Data Computer (Canada) Ltd.

Mississauga, Ontario
Tel. (416) 625-0770, TWX. 610-492-4382

Centronics Data Computer (U.K.) Ltd.

London, England
Tel. 011-44-464-5011, TLX. 851-877801

Centronics Data Computer (France)

50 Rue Dombasle, 75015 Paris, France
Tel. 828-4051, TLX. 202686

Centronics Data Computer (Germany), Gmbh

6000 Frankfurt am Main 71
Tel. 666-1021, TLX. 841-413224

Centronics of Puerto Rico

Dorado, Puerto Rico
Tel. (809) 796-1881, TLX. 385-9349

Centronics (Italia) S.P.A.

Via Santa Valeria 5, 20123 Milan, Italy
Tel. 809-514

© Copyright 1979 Centronics Data Computer Corp.
All rights reserved
Patents pending in U.S.A. and other countries
Printed in U.S.A.

Specifications subject to change without notice

TABLE OF CONTENTS

<u>Section</u>	<u>Page</u>
DESCRIPTION	1
SPECIFICATIONS	3
SETTING UP	4
RIBBON INSTALLATION	9
OPERATION	11
PRINCIPLES OF OPERATION	13
PRINTER INTERFACE	17
CHARACTER STYLES.	23
PROGRAMMING INFORMATION	25
MAINTENANCE	30

DESCRIPTION

The Model 737-1 is an operationally simple, compact, high density, dot-matrix impact printer which can print either monospaced or proportional characters in line lengths up to 8 inches. The ability to print monospaced and proportional characters coupled with the printer's ability to produce elongated and condensed characters makes possible a wide variety of character styles.

Monospaced characters may be printed at 10 characters per inch or 16.7 characters per inch which makes possible an 80 column or 132 column format for business applications. Proportional characters may be right justified under host control making the printer ideally suited for word processing and text preparation.

The printer provides near letter quality output using a heavy-duty free flight print head to form up to 9 vertical and from 6 to 18 horizontal dot placements in the generation of proportional (N x 9) characters. The printer also produces monospaced characters in a 7 x 8 matrix formation. The proportional and monospaced character sets consist of 96 ASCII characters.

The printer's three-way paper handling system allows the use of the following types of paper:

1. 9-1/2" wide standard computer fanfold forms, with fixed position pins to ensure pinfeed paper registration; paper can be multipart up to three parts.
2. Rolled paper, 8-1/2" wide, 1" core and up to 5" diameter. The printer includes a roll paper holder. With rolled paper a built-in rip-and-read cutting edge allows removal of paper within 5 lines of the last line printed.
3. Single sheets of 8-1/2 inch wide paper, hand fed as with an ordinary typewriter.

The 10 cpi, 16.7 cpi and proportional characters can be elongated beginning and ending anywhere within a line by host-generated control codes. Elongated characters are printed double-width, thus only half as many elongated characters can fit on a line.

Other significant features include:

- o Local paper feed, forward and reverse; one line or continuous.
- o Host-controlled forward and reverse paper feed in full-line and half-line increments.
- o Underscore capability.
- o Superscript and subscript capability.
- o Host-controlled backspace capability.

SPECIFICATIONS

Ribbon (12 per box)	20 yard Zip-Pack mobius loop (Centronics Part No. 63701468-6003)
Paper	Cut Sheets (8-1/2" wide) Rolls (3-1/2" to 8-1/2" wide x 5" diameter with 1" Core), 2 ply Fanfold (9" pin-to-pin), 3 ply
Printing Speed	22 lines per minute (lpm) at 80 characters per line (cpl) or 60 lpm at 20 cpl left justified
Characters Per Line	80 maximum (10 cpi); 132 maximum (16.7 cpi)
Print Width	8 inches maximum (204 mm)
Character Structure	Nx9 Dot Matrix (Proportionally Spaced) 7x8 Dot Matrix (Monospaced)
Line Feed Buffer	Capacity for 255 pending line feeds
Line Feed Repeat Rate	12 line feeds/second
Vertical Spacing	6 lines per inch
Horizontal Spacing	Monospaced: 10 or 16.7 characters per inch Proportional: 8.2 to 24.6 cpi depending on text; 13 to 14.5 cpi average density. Numerics are monospaced at 12.5 cpi for tabulating data.
Parallel Data Input Connector	40-pin PC edge connector
Code	Standard ASCII
Character Sets	Primary: 96 ASCII 10 cpi monospaced characters. Secondary: 96 ASCII proportionally space characters.
Input Data Format	7 parallel data bits
Input Data Rate	Up to 2,200 characters/second
Input Voltage/Frequency	115 VAC $\pm 10\%$, 60 Hz ± 1 Hz
Power Requirements	100 watts
Size	14-1/2"W x 11"D x 5"H; (368mm) x (279mm) x (127mm)
Weight	12 lbs (5.4 Kg)

SETTING UP

INSPECTION

Visually inspect the printer for signs of damage received during shipment. Notify the common carrier immediately of any discrepancies.

NOTE

Any attempt to operate a damaged printer voids the warranty and may cause further damage.

QUICK SET-UP PROCEDURES

1. Install roll paper holder and roll paper, fanfold paper, or single-sheet paper.
2. Remove top cover and check ribbon, then reinstall cover and install top paper guide.
3. Place POWER switch in the OFF position and place ON-LINE/LOCAL switch in LOCAL position.
4. Connect power cord to a 3-wire, grounded AC outlet.
5. Connect interface cable to printer interface connector.
6. Place POWER switch in ON position and observe that the LED illuminates through paper exit slot.
7. Place ON-LINE/LOCAL switch in ON-LINE position to receive data.

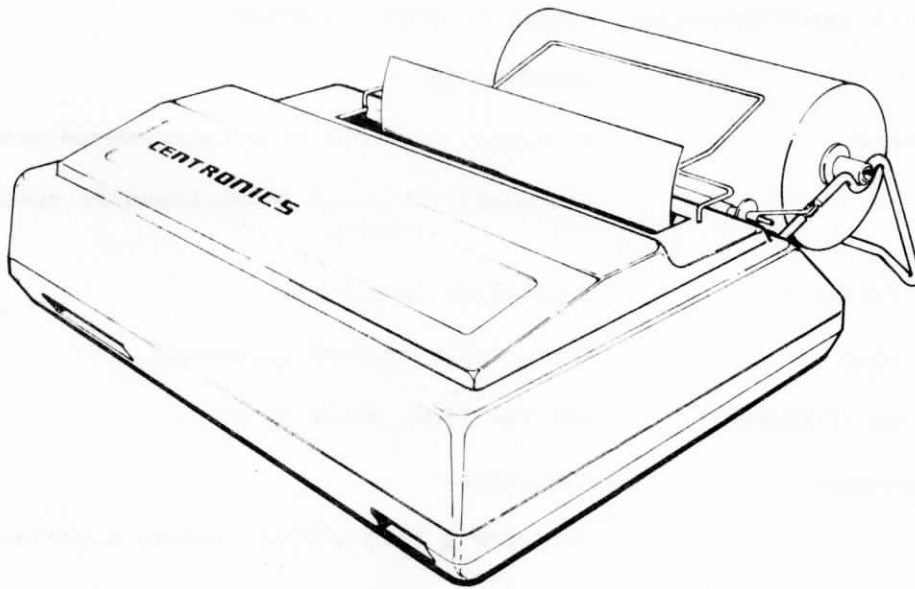

Figure 1. MODEL 737 PRINTER WITH ROLL PAPER

ROLL PAPER HOLDER INSTALLATION

1. Set the printer on a flat surface with enough room in back of the printer for the roll paper holder.
2. Refer to Figure 2 and squeeze the support arms together slightly.
3. Insert support arms into two holes provided at rear of printer and release support arms.
4. Remove core hub from plain end and insert roller through standard 1-inch paper roll core and place roll on holder as shown with paper feeding from bottom of roll.

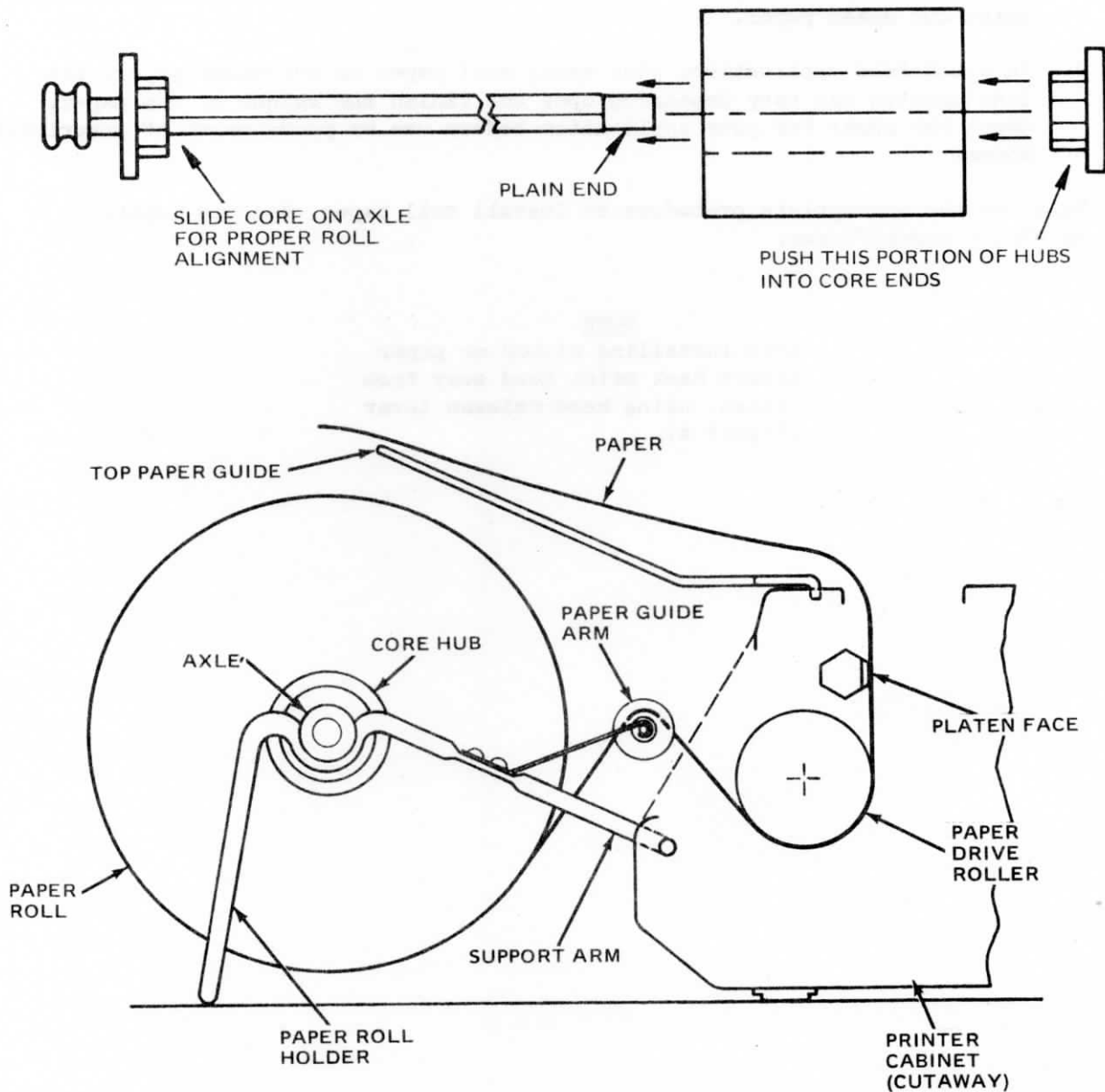

Figure 2. ROLL PAPER HOLDER INSTALLATION

PAPER INSTALLATION

Printer Forms Selection Guide

The printer has the unique ability to handle three common types of paper; cut sheet, roll, and fanfold. Line registration can vary depending on the type of paper stock being used. To select the ideal type of paper or form for your application you should consider the following guidelines:

1. Precise registration, 6 lines to the inch, can be best maintained by using continuous fanfold edge-punched paper. This type of paper should be used wherever registration is critical such as in preprinted forms applications.
2. The last line can be printed up to 1.6" from the bottom of the page when using cut sheet paper.
3. In pinch-feed applications when using roll paper or cut-sheet paper, the line spacing can vary depending upon the finish and weight of the paper. Check the paper for your application before use or procurement of preprinted forms.

Refer to the appropriate procedure to install roll paper, fanfold paper, or single sheets/forms.

NOTE

When installing ribbon or paper always back print head away from platen, using head-release lever (Figure 4).

Roll Paper

1. Install the roll on the paper holder as described previously.
2. Remove top cover by lifting at rear edge where paper enters.
3. Retract head to the paper/ribbon load position by rotating head release lever (Figure 4) fully counterclockwise.
4. Push the pinch-roller release lever towards rear of printer.
5. Feed the paper over the paper guide arm (Figure 2) and through the bottom rear of the printer under the paper drive roller.
6. Align the edges of the free end of paper with paper-drive roller edges and straighten as required.
7. Remove any skew between paper roll and the paper-drive roller by sliding the roll on the holder axle to align the paper as shown in Figure 3.

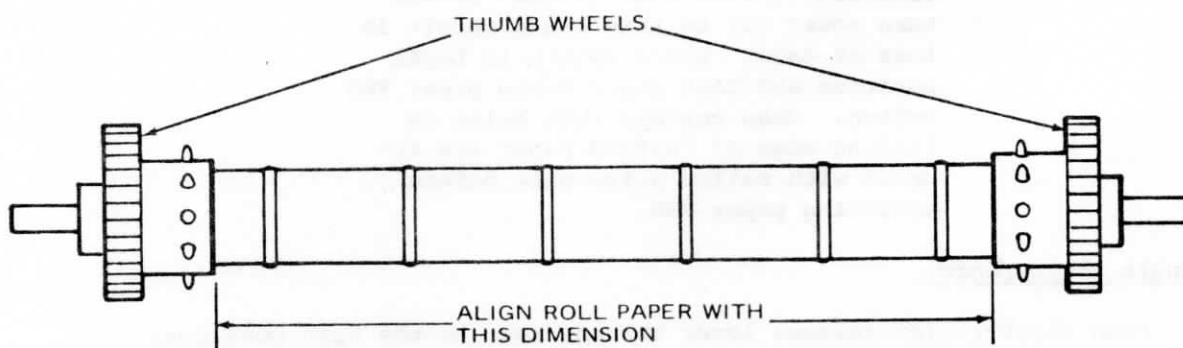

Figure 3. PAPER DRIVE ROLLER

8. Push the pinch-roller release lever forward to secure paper.
9. Advance paper into printer by turning either thumbwheel (power must be OFF) until paper exits through the top of the printer.
10. Check ribbon position, remove slack if necessary, move head-release lever to print position, and install top cover. Print position numbers on print head assembly indicate the basic setting for the number of plies of paper. Note that print-head position may vary depending upon type of paper being used.

Fanfold Paper

1. Remove the top cover, retract head and make sure release lever is in down position (open). For fanfold paper, paper feed may work best if lever remains in the open position.
2. Engage paper onto pins of paper-drive roller at bottom rear of printer.
3. Hold paper in place while turning either thumbwheel (power must be OFF) until the paper exits through the top of the printer.
4. Be sure the paper supply is feeding properly.
5. Check ribbon position, remove slack if necessary; move head-release lever to appropriate print position and install top cover. Print position numbers on print head assembly indicate the basic setting for the number of plies of paper. Note that the print-head position may vary depending upon type of paper being used.

NOTE

If replenishing paper during operation (interfaced with host device) DO NOT turn power off as this could result in loss of data. Place switch in LOCAL position and load paper using paper FWD switch. Make certain that holes in leading edge of fanfold paper are indexed with roller drive pins before actuating paper FWD.

Single Sheets/Forms

1. Push pinch-roller release lever towards rear to the open position.
2. Insert top edge of sheet/form through opening in the rear of the printer under the paper drive roller.
3. Slide sheet/form into rear of printer under paper-drive roller until sheet/form rises through paper-exit slot.
4. Match the top and bottom edges of paper. Straighten paper as required.
5. Pull pinch-roller release lever forward to closed position.
6. Manually turn either thumbwheel (power must be OFF) until sheet is in position for the first printed line.

RIBBON INSTALLATION

Zip-Pack ribbons are used with the printer. The procedure for installing the ribbon is as follows:

1. Remove printer top cover to gain access to ribbon tray.

NOTE

Use the throw-away plastic gloves provided with the new ribbon when performing the following steps.

2. Refer to the ribbon threading diagram. Move the driven roller away from the drive roller.
3. Retract the head by rotating the head-release lever (Figure 4) fully counterclockwise.
4. Unthread the old ribbon and discard it.
5. Remove the Zip-Pack from the plastic bag.
6. Place Zip-Pack in printer tray as shown in Figure 5.
7. Pull ribbon out from both ends of Zip-Pack and thread as shown in Figure 4, being careful to position mobius loop twist on the left side.
8. Hold ribbon in place by pressing down on plastic strip through hole in shell piece and then remove wrapper by pulling by the end.
9. Remove and discard shell and plastic strip.
10. Manually advance drive roller clockwise until slack is removed from ribbon.
11. Engage print head and install top cover.

RIBBON SPECIFICATIONS

The printer uses a 180° mobius loop ribbon configuration that allows printing on upper and lower portions of the ribbon on alternate passes, thereby increasing ribbon life. The specifications are as follows:

LENGTH:	20 yards (18.3 meters)
WIDTH:	9/16 inch \pm 1/64 inch (14.3 meters \pm 0.5 mm)
THICKNESS:	0.0004 inch \pm 0.00025 inch (0.1 mm \pm 0.00064 mm)

Ribbons may be obtained from Centronics in packages of one dozen. The part number for one dozen ribbons is 63701648-6003. The ribbon color is black.

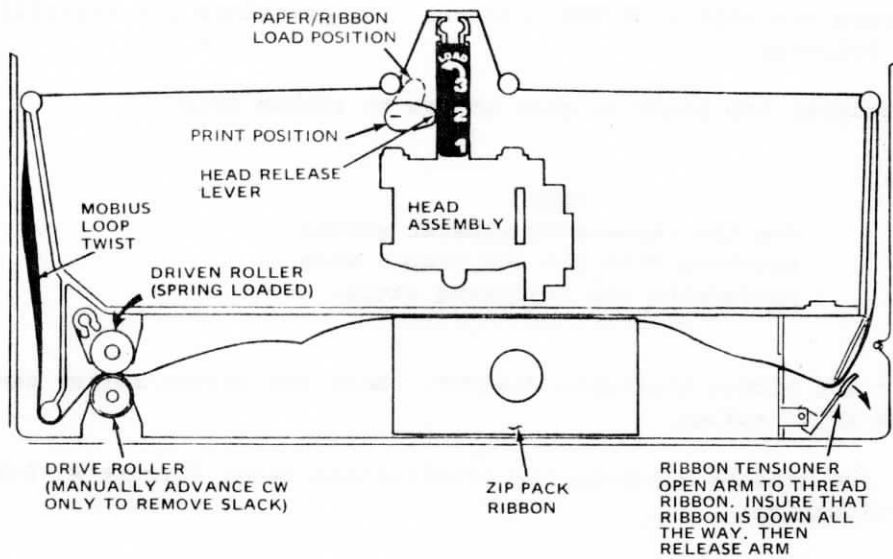

Figure 4. RIBBON THREADING DIAGRAM

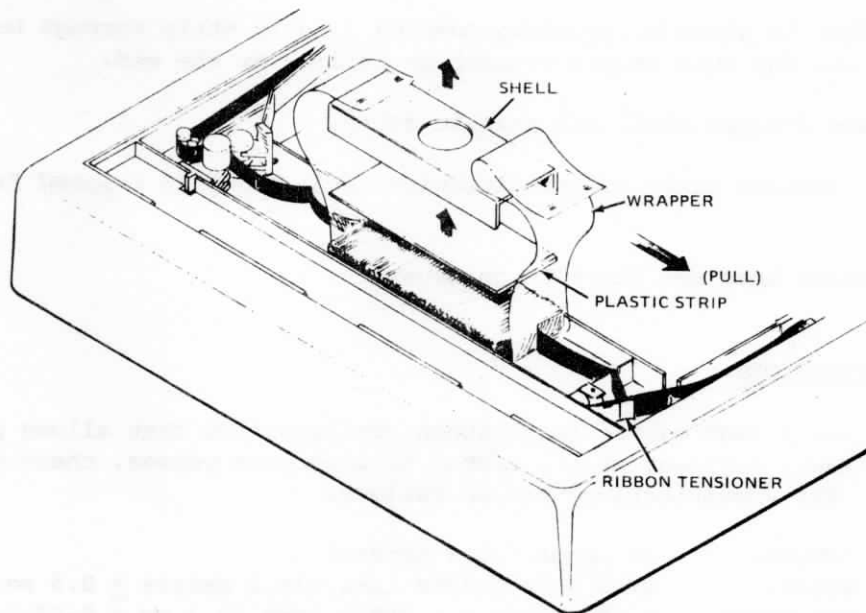

Figure 5. ZIP-PACK INSTALLATION DIAGRAM

OPERATION

USING THE PRINTER

1. Ensure that a ribbon is installed in the printer and that an adequate supply of paper has been installed.
2. Place ON-LINE/LOCAL switch in LOCAL position. This prevents the printer from printing and keeps it "off-line".
3. Place POWER ON/OFF switch in ON position (this automatically selects 10 cpi monospaced characters). "Power On" LED should be visible through paper-exit slot.

CAUTION

When turning power on or off the ON-LINE/LOCAL switch should first be placed in the LOCAL position to prevent erroneous communications between the host device and the printer.

4. Place ON-LINE/LOCAL switch in the ON-LINE position. Printer is ready to accept data.
5. With the switch in the LOCAL position, the PAPER REV/FWD switch may be used. Momentary movement of the switch to the FWD position advances paper one line; momentary movement of the switch to the REV position moves paper down one line. Holding the switch in either position for more than 1/2 second causes continuous paper movement.
6. To turn printer off, place ON-LINE/LOCAL switch in LOCAL position, then place POWER ON/OFF switch in OFF position.

OPERATING NOTES

- o Always plug printer into a 3-wire grounded outlet.
- o Do not place objects on any part of printer.
- o Do not subject printer to temperatures below +40°F during operation, to a sudden change in temperature, to dust, or to extreme shock.
- o Use only a dry, soft cloth to clean printer surfaces. Do not use harsh detergents or chemicals.
- o Periodically clean ink build-up from ribbon guide path and remove paper dust from interior.
- o Always place ON-LINE/LOCAL switch in LOCAL position before turning printer on or off.

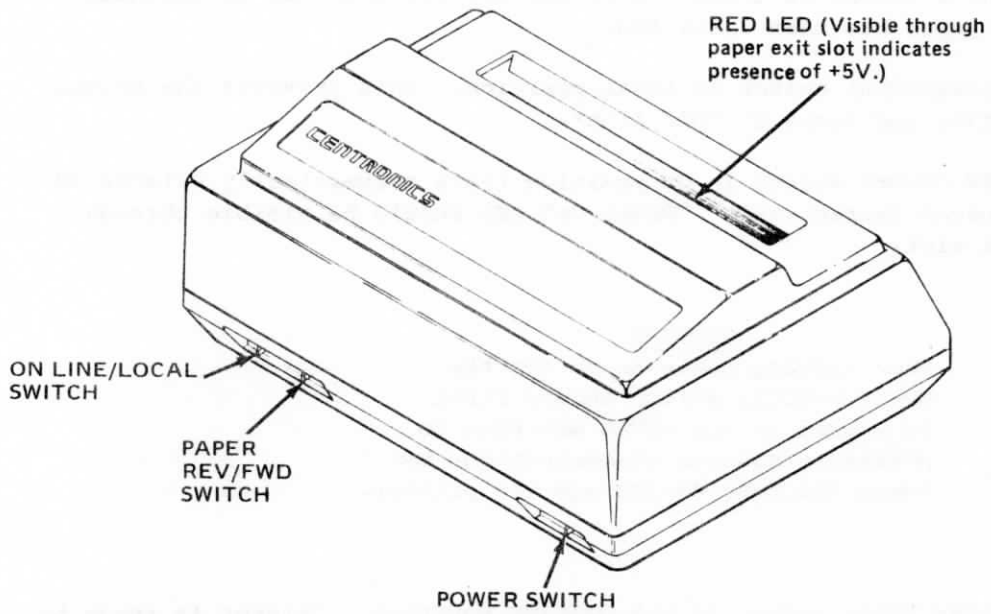

FRONT

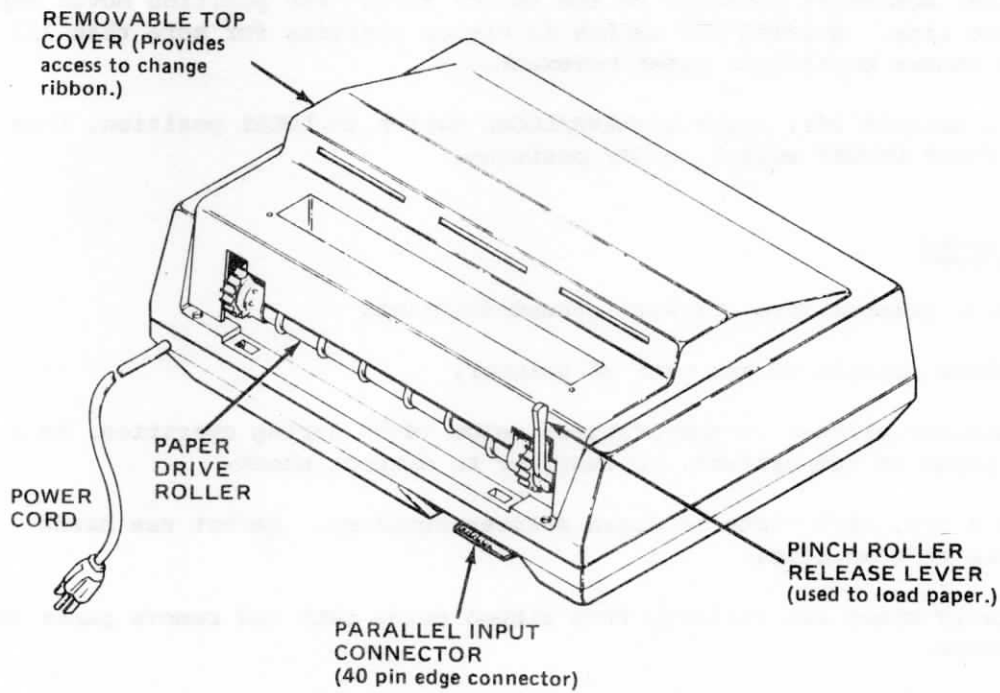

REAR

Figure 6. OPERATOR CONTROLS

The printer is capable of printing 80 monospaced characters per line; 10 characters per inch (10 cpi). The monospace matrix is 7x8, in upper and lower-case characters. Monospace descenders (y, g etc.) do not touch the underline (if used), which is provided by activating the 9th pin for all characters to be underlined (including intercharacter and interword spaces if appropriate). Underline may be turned on or off anywhere within a line and as many times as desired, for all character sets. Monospaced characters may be condensed to 16.7 cpi, resulting in 132 character per line.

The secondary character set is proportionally spaced, printed in Nx9 (N = 6 to 18) dot matrix. The proportional descenders (y, g etc.) will run into the underline because the 9th pin is used to form proportional descenders. Proportional text may be right justified through the use of intercharacter and inter-word spaces generated by the host device.

Average character spacing for proportional is approximately 14 cpi; however, numerals 0-9 are monospaced at 12.5 cpi to allow tabulation. Rather than counting characters to determine a full line, columns are counted for the proportional set, 1200 columns making a full line. If the host device does not transmit a Carriage Return (CR) to end the line at this point, the logic terminates the line with CR after counting and accepting every column of the character that exceeds a count of 1185, regardless of the width of the character (even an elongated W). The remainder of a truncated word (if this is the case) would begin on the next line. For monospaced 10 cpi, CR occurs at 80 characters, and for condensed (16.7 cpi), CR occurs at 132 characters.

All three basic character sets (proportional, monospaced and condensed) may be elongated beginning anywhere in the line after the host transmits ESC, SO. Elongation is accomplished by simply printing each character column twice. This results in half as many characters per inch for all character sets, and a wider, bold-appearing character. ESC, SI terminates the elongated characters.

Line feed (LF) control codes received by the printer control paper movement. Each line feed code received causes the paper to be advanced one line. The printer has a special line feed buffer, separate from the holding buffer, which can store up to 255 line feed commands. LF control codes are received at the same data transfer rate as character data (up to 2200 characters per second). The initial LF code causes an immediate advance of one line. Additional line feed codes received are stored as a count in the line feed buffer. Line feed codes and character data sent to the printer may be inter-mixed; however, all line feeds received are performed before printing the next line of data.

Line feed codes may be used for limited paper-handling functions. Each line feed code moves the paper one-sixth of an inch. Thus, if it is desired to move the paper 12 inches, 72 line feed codes are required.

Automatic line feed upon completion of each line may be disabled by removing resistor R11 (270 ohms) from the printed circuit board. With automatic line feed disabled, the first line of data is printed when a CR control code is sent by the host device, or when 80 characters are counted by the printer logic for 10 cpi; 132 characters for 16.7 cpi, or 1186 dot spaces are counted for proportional. The print head returns to the left margin after printing the line, but the paper is not advanced. Thus, an LF control code must be sent after each CR control code to end a normal text line. Otherwise, overprinting will occur with automatic LF disabled.

Figure 8 shows the printer interface timing. Each set of data bits (1-7) sent to the printer is strobed by the DATA STROBE signal (sent by the host device). Within 50 nsec following the trailing edge of the DATA STROBE signal a BUSY signal is generated by the printer which is sent to the host device. The BUSY signal informs the host device that the printer is processing the input data and that no additional data from the host device will be accepted by the printer. After completion of processing the input data an ACKNLG signal is sent to the host device indicating that the data sent by the host device has been accepted and processed. Within 50 nsec following the leading edge of the ACKNLG signal the BUSY signal is terminated, indicating that the printer is again ready to accept additional input data. A DEMAND signal is also generated by the printer and is available to the host device. The DEMAND signal is the inverse of the BUSY signal and when present (positive) indicates that the printer is not busy and is ready to accept data.

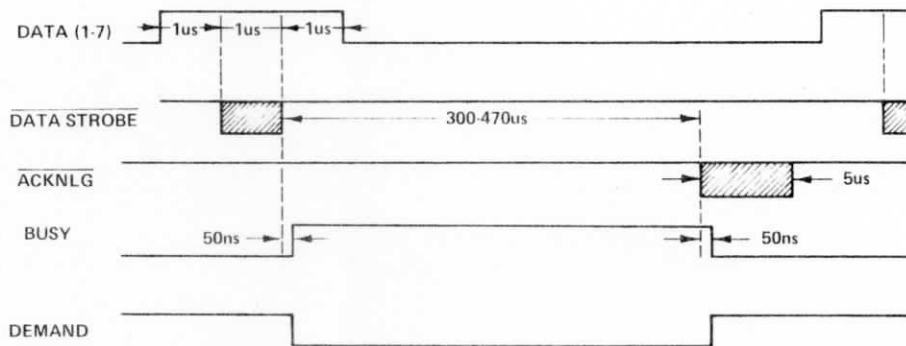

Figure 8. INTERFACE TIMING

The Power ON/OFF switch controls the application of electrical power to the printer. When power is turned on, an LED visible through the paper exit slot indicates that the +5 volts is active. The ON-LINE/LOCAL switch controls the printer modes of operation. When placed in the LOCAL position, the printer is placed in a local mode of operation and a BUSY signal is sent to the host device. When placed in the ON-LINE position, the print head is returned to the left margin and the BUSY signal is discontinued allowing data to be sent by the host device. If the switch is placed in the OFF-LINE position when the printer is processing a line of data, the printer will complete printing the line of data and return the print head to the left margin. If the printer is performing multiple line feeds at the time that the switch is placed in the LOCAL position, the line feed operation currently being performed is completed and the remaining line feeds are processed only when the printer is returned to the on-line mode. The switch should be placed in the LOCAL position when turning power to the printer on or off as extraneous acknowledge (ACKNLG) signals can occur when power is turned on or off.

PRINTER INTERFACE

PRINTER INTERFACE CONNECTIONS

Printer Interface Connector

A 40-pin printed circuit edge-card connector located at the left rear of the printer provides the means for connecting the printer to an input device. A mating connector for preparing a customer-supplied interface cable may be procured from Centronics (Part No. 31230032). Two alternate sources of mating connectors are 3M (Part No. 3464-0001) and T&B Ansley (Part No. 609-4015M.) The physical and electrical characteristics, pin orientation, and connector pin-outs of the printer interface connector are shown below.

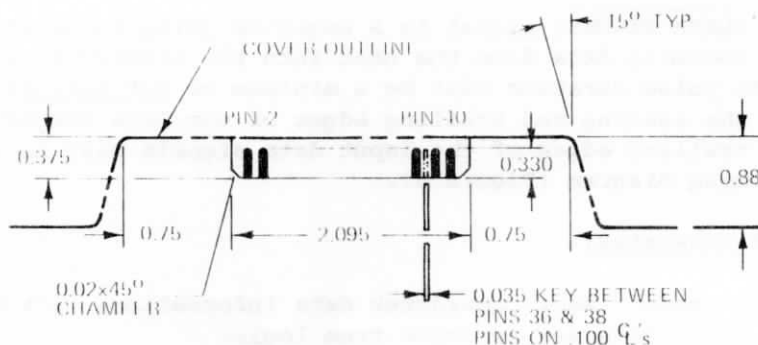

Figure 9. TOP VIEW OF PRINTER INTERFACE CONNECTOR

PRINTER INTERFACE CONNECTOR PIN-OUTS

<u>PIN</u>	<u>SIGNAL</u>	<u>PIN</u>	<u>SIGNAL</u>
1	DATA STROBE	2	TWISTED PAIR GROUND (DATA STROBE)
3	DATA BIT 1	4	TWISTED PAIR GROUND (DATA BIT 1)
5	DATA BIT 2	6	TWISTED PAIR GROUND (DATA BIT 2)
7	DATA BIT 3	8	TWISTED PAIR GROUND (DATA BIT 3)
9	DATA BIT 4	10	TWISTED PAIR GROUND (DATA BIT 4)
11	DATA BIT 5	12	TWISTED PAIR GROUND (DATA BIT 5)
13	DATA BIT 6	14	TWISTED PAIR GROUND (DATA BIT 6)
15	DATA BIT 7	16	TWISTED PAIR GROUND (DATA BIT 7)
17	DATA BIT 8	18	TWISTED PAIR GROUND (DATA BIT 8)
19	ACKNOWLEDGE	20	TWISTED PAIR GROUND (ACKNOWLEDGE)
21	BUSY	22	TWISTED PAIR GROUND (BUSY)
23	ALWAYS LOGIC 0 (GROUND)	24	TWISTED PAIR GROUND (DEMAND)
25	ON-LINE	26	NOT USED
27	SIGNAL GROUND	28	ALWAYS LOGIC 1
29	NOT USED	30	GROUND
31	SIGNAL GROUND	32	PIN 32 JUMPERED TO PIN 34
33	CHASSIS GROUND	34	FOR SENSING PRINTER CONNECTED
35	+5V SIGNAL (P.S. ON)	36	DEMAND
37	+17V	38	NOT USED
39	+17V	40	NOT USED

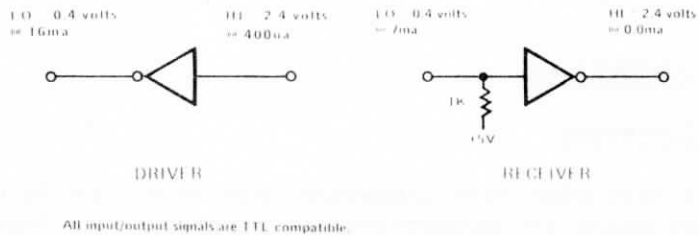

Figure 10. INTERFACE DRIVERS AND RECEIVERS

INPUT/OUTPUT SIGNAL DESCRIPTIONS

Data Strobe (Host Generated)

The data strobe (DATA STROBE) signal is a negative-going pulse which is used to transfer the incoming data from the host into the electronic circuitry of the printer. The pulse duration must be a minimum of one microsecond. The relationship of the leading and trailing edges of the DATA STROBE signal with the leading and trailing edges of the input data signals must be as shown in the interface timing diagram (Figure 8).

Data Lines (Host Generated)

Data bits DB1-DB7 contain ASCII character data information. Bit 8 (DB8) is inactive. Data bit levels are positive true logic.

Acknowledge (Printer Generated)

The acknowledge (ACKNLG) signal is a negative-going signal which indicates that the printer has processed the latest data transferred from the host. No new data can be sent to the printer until the leading edge of the ACKNLG pulse has occurred. If the printer receives a carriage return (CR) control code, or if the printer print buffer or line feed buffer becomes full, the acknowledge pulse will not occur until after the line has been printed or until the line feed buffer becomes only partially full.

Busy (Printer Generated)

The BUSY signal is a positive-going signal which indicates the time when the printer cannot accept new data. The BUSY signal goes positive on the trailing edge of every data strobe pulse and remains high until the leading edge of the acknowledge pulse. No new data can be sent to the printer while the BUSY signal is high.

Demand (Printer Generated)

The DEMAND signal is the inverse of the BUSY signal. When high (positive), the DEMAND signal indicates that the printer can accept data.

+5V Signal (Printer Generated)

The +5V signal (I/O Connector, Pin 35) indicates that the +5V power supply is operating in the printer. The +5V signal is intended to be used for signal purposes only and it must not be used to provide power to external equipment.

HOST-GENERATED CONTROL CODES

Control code data is sent to the printer along with character code data via the input data lines. Control codes are interpreted as instructions by the printer. The following is a summary of the control codes and control code sequences recognized by the printer. Each of the control codes is described in detail in the following paragraphs.

<u>Mnemonic</u>	<u>Decimal</u>	<u>Octal Code</u>	<u>Hex Code</u>	<u>Function</u>
LF	10	012	0A	Full Line Feed Forward
CR	13	015	0D	Print Command
ESC, SOH	27, 01	033, 001	1B, 01	1 Dot Space
ESC, STX	27, 02	033, 002	1B, 02	2 Dot Spaces
ESC, ETX	27, 03	033, 003	1B, 03	3 Dot Spaces
ESC, EOT	27, 04	033, 004	1B, 04	4 Dot Spaces
ESC, ENQ	27, 05	033, 005	1B, 05	5 Dot Spaces
ESC, ACK	27, 06	033, 006	1B, 06	6 Dot Spaces
ESC, LF	27, 10	033, 012	1B, 0A	Full Line Feed Reverse
ESC, SO	27, 14	033, 016	1B, 0E	Start Elongated Print
ESC, SI	27, 15	033, 017	1B, 0F	Stop Elongated Print
ESC, DC1	27, 17	033, 021	1B, 11	Select Secondary Character Set (Proportional)
ESC, DC3	27, 19	033, 023	1B, 13	Select Primary Character Set (10 cpi Monospaced)
ESC, DC4	27, 20	033, 024	1B, 14	Select 16.7 cpi (Monospaced)
ESC, FS	27, 28	033, 034	1B, 1C	Half Line Feed Forward
ESC, RS	27, 30	033, 036	1B, 1E	Half Line Feed Reverse
SI	15	017	0F	Start Underline
SO	14	016	0E	Stop Underline
BS*	08	010	08	Backspace

*BS must be followed by a number that defines the dot spaces to Backspace.

Line Feed (LF) Code

Each LF code received by the printer causes the paper to advance one line (one-sixth inch). Consecutive line feeds are received at the character code rate, but the first LF code is acted upon immediately and subsequent LF codes are counted, pending execution by the roller stepper motor. As each pending LF is executed, the count is decremented until all consecutive LF codes are executed and the Line Feed Counter has a count of zero. If a stream of LF codes causes the count to be 255, the Busy signal stays active until the count is decremented (by one). Whenever an LF code is sent after text, the text is printed before the LF code(s) is executed, and text following the LF code will be printed on the line below. Note that LF codes do not reset the character count (or dot position count) thus, text following LF codes will not be printed starting at the left margin unless a CR code is sent prior to the LF code.

Carriage Return (CR) Code

When a CR code is received, it is a print command and carriage-return function. Receipt of a CR code causes immediate printing of characters in the printer character buffer, then the carriage returns to the left margin and the character count (or dot position count) is reset to zero. The printer logic generates a CR code on a buffer full condition. Buffer full equals 80 characters in 10 cpi monospaced mode, or 132 characters in 16.7 cpi monospaced mode, or 1186 dot positions in proportional spaced (or mixed proportional spaced and 16.7 cpi monospaced mode).

Intercharacter/Interword Spacing for Justification (ESC, SOH, etc.)

Right justification of the proportional or 16.7 cpi monospaced characters may be accomplished using spacing commands ESC, SOH (1 dot space); ESC, STX (2 dot spaces); ESC, ETX (3 dot spaces); ESC, EOT (4 dot spaces); ESC, ENQ (5 dot spaces) and ESC, ACK (6 dot spaces). The host device must provide the appropriate control codes so that the printed text is right justified at the desired line measure up to 8 inches. Note that after 1185 dot positions, the next character received forces a CR code to end the line. Right justification is not recommended for 10 cpi monospaced.

Full Line Feed Reverse (ESC, LF)

ESC, LF activates one line feed (one-sixth inch) in reverse. Text prior to the ESC, LF code sequence is printed before execution of the reverse line feed. The character count (or dot position count) is not changed; thus, characters following ESC, LF will be printed one line above the previous text.

Elongated Characters (ESC, SO; ESC, SI)

When an ESC, SO code sequence is received, all subsequent characters are printed double width (elongated). The reception of an ESC, SI code sequence or end of a print line terminates elongated characters. Elongated character start and stop (ESC, SO; ESC, SI) may be entered any number of times within a line and can be used with 10 cpi monospaced, 16.7 cpi monospaced and proportional character sets.

Select Proportional Character Set (ESC, DC1)

The secondary character set is proportional. ESC, DC1 code sequence selects the proportional set to begin a line (terminating the present character set) or may be sent by the host in a line containing 16.7 cpi monospaced for style mixing. The logic will accommodate mixing of proportional and 16.7 cpi monospace, but 10 cpi mixing is not recommended. Proportional characters are terminated by selecting another character set (ESC, DC3 or ESC, DC4).

Select 10 CPI Monospaced Character Set (ESC, DC3)

The primary character set is 10 cpi monospaced, selected by the printer logic during initialization, or by ESC, DC3. The selection of the 10 cpi character set should be done only at the beginning of the line, and the other two sets should not be mixed with it. 10 cpi monospaced is terminated by selecting another character set (ESC, DC1 or ESC, DC4) at the beginning of a new line.

Select 16.7 CPI Monospaced (Condensed) Character Set (ESC, DC4)

When ESC, DC4 is received, all following text will be printed in 16.7 cpi monospaced, providing a 132 character-per-line capability. If desired, ESC, DC1 may be sent within the same line to set proportional characters for style mixing. 16.7 cpi monospaced characters may be terminated by selecting another character set (ESC, DC1 at any point; ESC, DC3 at the beginning of the next line).

Half Line Feed Forward (ESC, FS)

The receipt of an ESC, FS sequence causes immediate printing of text, then the paper is advanced one-half line (one-twelfth inch). A new baseline is created for any text that follows; thus, this function can be used for subscript characters. The original baseline can be reinstated using an ESC, RS code sequence. The subscript characters will be printed, then the paper will move one-half line in reverse, back to the original baseline.

Half Line Feed Reverse (ESC, RS)

ESC, RS causes immediate printing of previous text, then the paper is moved in reverse one-half line (one-twelfth inch). A new baseline is created for any text that follows; thus, this function can be used for superscript characters. The original baseline can be reinstated using an ESC, FS code sequence. The superscript characters will be printed, then the paper will move one-half line forward (to the original baseline).

Start Underline (SI), Stop Underline (SO)

Receipt of an SI code causes all following characters to be underlined. Underlining is accomplished by driving pin 9 to create a continuous, unbroken line until an SO code is received, which terminates the underlining. End of printed line does not terminate underlining. Proportional descenders will touch the underline, as they are partly formed by the 9th pin. Monospaced 10 cpi and 16.7 cpi character descenders are above the underline.

Backspace N Dot Positions (BS, "N")

The printer may be backspaced from 1 to 126 dot positions by the BS, "N" sequence. "N" is a 7-bit digital value from 0000001 to 1111110 to define the backspace number. The receipt of BS, "N" causes immediate printing of previous text, the carriage returns to the left margin then moves out to the new dot column position indicated by the character pointer (which was decremented by the backspace number "N"). If greater than 126 dot position backspace is desired, consecutive BS, "N" codes may be sent. If "N" exceeds the present dot position, the character pointer is reset to zero. If BS, NULL (N = 0) is sent, no operation takes place; the code sequence is ignored (NO-OP). BS, "N" cannot be sent after the 80th character (10 cpi), 132nd character (16.7 cpi) or 1186th dot position, as a buffer full condition exists and the line is terminated and printed automatically.

Backspacing Characters

For backspacing of a character or space, the code sequences for the three basic character sets are shown below. The second number in each command represents the dot width of a character or space for that character set. To backspace for elongated characters, this number must be doubled.

CH SET	DOTS	CODE	HEX	DECIMAL	OCTAL	BINARY
10 cpi	10	BS, 10	08, 0A	08, 10	10, 12	0001000, 0001010
16.7 cpi	9	BS, 9	08, 09	08, 09	10, 11	0001000, 0001001
Prop*	6-18*	BS, N*	08, N*	08, N*	10, N*	0001000, XXXXXXX*

*For proportional character dot widths, refer to Figure 13 Proportional Character Style Code Chart.

CHARACTER STYLES

General

Three character styles; proportional, standard (10 cpi) and condensed (16.7 cpi) can be printed. The proportional characters are formed using an N x 9 character matrix. The standard and condensed characters are formed using a 7 x 8 character matrix. Any of the three character styles may be selected using host-generated control codes. When the printer is initially turned on the 10 cpi character style is automatically selected. Proportional characters and condensed (16.7 cpi) characters may be intermixed within lines of data. Standard (10 cpi) characters cannot be intermixed with condensed (16.7 cpi) or proportional characters within lines of data.

Any of the three character styles may be printed as elongated characters. Elongated characters are double-width characters formed by printing each column of dots within each character twice. Spaces between characters and words in this mode are also double-width.

Figure 11 shows each of the character styles, both normal and elongated. The following paragraphs describe each of the various styles and the control codes required for their selection.

Proportional Characters

Proportional characters are selected by using the ESC, DC1 control code sequence. The characters are N x 9 characters whose widths vary from 6 dot columns to 18 dot spaces. All numerals in this character style are the same width (12 dot spaces). This allows tabular numbers to be aligned vertically.

Standard (10 CPI) Monospaced Characters

Standard (10 cpi) monospaced characters are initiated during power up or by using the ESC, DC3 control code sequence. Standard monospaced characters are 7 x 8 characters printed at 10 characters per inch (80 characters per line).

Condensed (16.7 CPI) Monospaced Characters

Condensed (16.7 cpi) monospaced characters are initiated using the ESC, DC4 control code sequence. Condensed monospaced characters are 7 x 8 characters printed at 16.7 characters per inch (132 characters per line).

Elongated Characters

Elongated characters in all three character styles are initiated using the ESC, SO control code sequence and terminated using the ESC, SI control code sequence. Printing of elongated characters may be initiated and terminated within a line, which allows intermixing of normal and elongated characters within lines. Printing of elongated characters is automatically terminated at the end of a line. Carry-over of elongated characters to the next line must be accomplished by using the ESC, SO code sequence preceding the character data for the next line.

PROPORTIONAL NORMAL

!"#\$%&'()*+,-./0123456789:;<=>?
@ABCDEFGHIJKLMNPOQRSTUVWXYZ[\]^_
'abcdefghijklmnopqrstuvwxyz{|}~

PROPORTIONAL ELONGATED

!"#\$%&'()*+,-./0123456789:;<=>?
@ABCDEFGHIJKLMNPOQRSTUVWXYZ[\]^_
'abcdefghijklmnopqrstuvwxyz{|}~

10 CPI NORMAL

!"#\$%&'()*+,-./0123456789:;<=>?
@ABCDEFGHIJKLMNPOQRSTUVWXYZ[\]^_
'abcdefghijklmnopqrstuvwxyz{|}~

10 CPI ELONGATED

!"#\$%&'()*+,-./0123456789:;<=>?
@ABCDEFGHIJKLMNPOQRSTUVWXYZ[\]^_
'abcdefghijklmnopqrstuvwxyz{|}~

CONDENSED (16.7 CPI) NORMAL

!"#\$%&'()*+,-./0123456789:;<=>?
@ABCDEFGHIJKLMNPOQRSTUVWXYZ[\]^_
'abcdefghijklmnopqrstuvwxyz{|}~

CONDENSED (16.7 CPI) ELONGATED

!"#\$%&'()*+,-./0123456789:;<=>?
@ABCDEFGHIJKLMNPOQRSTUVWXYZ[\]^_
'abcdefghijklmnopqrstuvwxyz{|}~

Figure 11. CHARACTER STYLES

PROGRAMMING INFORMATION

PROGRAMMING CONSIDERATIONS

The printer operates under the complete control of the host device which must be programmed to provide the proper instructions to the printer for desired outputs. The following paragraphs summarize some of the items which must be considered when programming the host device.

1. When the printer is turned on, normal 10 cpi monospaced characters are automatically initiated.
2. 10 cpi monospaced characters cannot be intermixed with proportional or condensed characters in the same line.
3. The use of justification codes with 10 cpi monospaced characters is not recommended.
4. Elongated characters are automatically terminated at the end of a line.
5. Underline is NOT terminated at the end of a line and continues until a terminating command (SO) is sent by the host device.
6. When the auto line feed after carriage return function is enabled the print head moves to left margin after printing, then paper is advanced one line.
7. When the auto line feed after carriage return function is disabled the print head moves to the left margin after printing, but paper is NOT advanced. When in this mode all carriage return (CR) commands should be immediately followed by a line feed command to prevent overprinting.
8. Half line feed commands (forward or reverse) cause printing prior to the line feed. The print head is returned to the left margin after printing, then moves out to the position where the last character ended.
9. Half line feeds cause new character baselines one half space below (forward) or above (reverse) the former baseline. When subsequent data is printed it will be printed on the new baseline.
10. Multiple sequential line feeds, partial or full, are logically summed prior to their execution.
11. A line feed command (full or half) causes immediate printing of all preceding data in a line prior to execution of the line feed. The print head is moved to the left margin after printing, then moves to the position above or below the last character printed.
12. A CR command causes all preceding data in a line to be printed then returns the print head to left margin and resets the dot position counter (or character counter) to zero.

13. A backspace control code (BS, "N") cannot be sent after the 80th character (10 cpi), 132nd character (16.7 cpi), or 1186th dot position (proportional) as a buffer full condition would occur causing the line to be printed prior to the receipt of the backspace command.

RIGHT JUSTIFICATION

Data printed using proportional or condensed (16.7 cpi) character styles may be right justified using a host device program. Right justification is accomplished by adjusting the width of spaces between words and/or characters. The justification control code sequences allow "dot spaces" to be inserted anywhere within a line of data either between words or between characters. The justification control code sequences are as follows:

<u>ASCII</u>				
<u>Mnemonic</u>	<u>Decimal</u>	<u>Octal Code</u>	<u>Hex Code</u>	<u>Function</u>
ESC, SOH	27, 01	033, 001	1B, 01	One Dot Space
ESC, STX	27, 02	033, 002	1B, 02	Two Dot Spaces
ESC, ETX	27, 03	033, 003	1B, 03	Three Dot Spaces
ESC, EOT	27, 04	033, 004	1B, 04	Four Dot Spaces
ESC, ENQ	27, 05	033, 005	1B, 05	Five Dot Spaces
ESC, ACK	27, 06	033, 006	1B, 06	Six Dot Spaces

Line lengths may be extended by inserting dot spaces between words or between characters as desired within a line of data. Line lengths may be compressed by replacing normal spaces (normal space = 7 dot columns) with shorter dot spaces.

The following items must be considered when preparing a host device control program.

Dot Columns

Dot column spacing may be calculated from the following values:

Maximum Line Length = 1185 dot columns
Dot Column Density = 150 dot columns/inch
Dot Column Width = 0.00666 inches/dot column

Note that when preparing host device right-justification programs, the longest line to be considered is 1185 dot columns in length. This is because lines of data sent to the printer which exceed 1185 dot columns in length cause a buffer-full condition in the printer. This results in automatic printing of the line of data, causes loss of print control by the host device, and random lengths of lines may be printed.

Proportional Characters

Proportional characters vary in width from 6 to 18 dot spaces. The host device justification program must accommodate the variations in proportional character dot widths. Figure 12 shows the proportional characters arranged by dot widths. Figure 13 shows the proportional characters arranged in ascending ASCII code. All codes are in octal. Octal 177 (delete character) is ignored by the software and is not used.

Condensed (16.7 CPI) Characters

Condensed (16.7 cpi) characters are all formed using a 7 x 8 character matrix. When printing condensed characters the printer electronics automatically adds a two dot intercharacter space following each character. For programming purposes, all condensed (16.7 cpi) characters including normal spaces are to be considered 9 dot spaces wide. Figure 13 may be used as a reference for the ASCII codes for each character, but dot widths shown in Figure 13 are for proportional characters only.

Mixed Proportional and Condensed (16.7 CPI) Characters

Proportional and condensed (16.7 cpi) characters may be intermixed within a line. The host device justification program must be able to accommodate dot column widths for both proportional and condensed characters when they are printed in the same line.

Elongated Characters

Elongated characters may be intermixed with normal characters within a line. The dot widths for elongated characters are twice those of normal characters (12 to 36 for proportional characters; 18 for condensed characters).

6 DOTS	7 DOTS	8 DOTS	10 DOTS
j - 152	Space - 040	i - 151	" - 042
	! - 041	l - 154	I - 111
	' - 047		Z - 132
	(- 050		c - 143
) - 051		f - 146
	' - 054		r - 162
	. - 056		t - 164
	: - 072		z - 172
	; - 073		} - 173
	\ - 140		} - 175
	- 174		

12 DOTS

\$ - 044	6 - 066] - 135	o - 157
* - 052	7 - 067	^ - 136	p - 160
+ - 053	8 - 070	underline - 137	q - 161
- - 055	9 - 071	a - 141	s - 163
/ - 057	< - 074	b - 142	u - 165
0 - 060	= - 075	d - 144	v - 166
1 - 061	> - 076	e - 145	x - 170
2 - 062	? - 077	g - 147	y - 171
3 - 063	S - 123	h - 150	~ - 176
4 - 064	[- 133	k - 153	
5 065	\ - 134	n - 156	

14 DOTS	15 DOTS	16 DOTS	18 DOTS
@ - 100	# - 043	% - 045	M - 115
C - 103	B - 102	A - 101	W - 127
E - 105	R - 122	D - 104	
F - 106		G - 107	
J - 112		H - 110	
L - 114		K - 113	
P - 120		N - 116	
Q - 121		O - 117	
T - 124		U - 125	
& - 046		V - 126	
		X - 130	
		Y - 131	
		m - 155	
		w - 167	

Figure 12. PROPORTIONAL CHARACTER SET DOT WIDTHS

CODE CHAR WIDTH	040 SP 7	041 ! 7	042 " 10	043 # 15	044 \$ 12	045 % 16	046 & 14	047 , Accent 7 Acute
CODE CHAR WIDTH	050 (7	051) 7	052 * 12	053 + 12	054 , Comma 7	055 - 12	056 . 7	057 / Right Slash 12
CODE CHAR WIDTH	060 0 12	061 1 12	062 2 12	063 3 12	064 4 12	065 5 12	066 6 12	067 7 12
CODE CHAR WIDTH	070 8 12	071 9 12	072 : 7	073 ; 7	074 < 12	075 = 12	076 > 12	077 ? 12
CODE CHAR WIDTH	100 @ 14	101 A 16	102 B 15	103 C 14	104 D 16	105 E 14	106 F 14	107 G 16
CODE CHAR WIDTH	110 H 16	111 I 10	112 J 14	113 K 16	114 L 18	115 M 18	116 N 12	117 O 16
CODE CHAR WIDTH	120 P 14	121 Q 14	122 R 15	123 S 12	124 T 14	125 U 16	126 V 16	127 W 18
CODE CHAR WIDTH	130 X 16	131 Y 16	132 Z 10	133 [12	134 \ Left Slash 12	135 J 12	136 ^ 12	137 _ Under- line 12
CODE CHAR WIDTH	140 \ Accent 7 Grave 12	141 a 12	142 b 12	143 c 10	144 d 12	145 e 12	146 f 10	147 g 12
CODE CHAR WIDTH	150 h 12	151 i 8	152 j 6	153 k 12	154 l 8	155 m 16	156 n 12	157 o 12
CODE CHAR WIDTH	160 p 12	161 q 12	162 r 10	163 s 12	164 t 10	165 u 12	166 v 12	167 w 16
CODE CHAR WIDTH	170 x 12	171 y 12	172 z 10	173 { 10	174 Vertical Rule 7	175 } 10	176 ~ 12	177 Not Used -

Figure 13. PROPORTIONAL CHARACTER STYLE CODE CHART (OCTAL CODES)

MAINTENANCE

PREVENTIVE MAINTENANCE

Routine preventive maintenance should be performed at regular intervals to insure satisfactory performance of the printer. The preventive maintenance required consists of periodic cleaning, inspection, and lubrication. The recommended preventive maintenance and suggested frequencies are shown below. Preventive maintenance may be required more or less frequently than indicated depending upon the printer application, operating environment, and type of paper/forms used.

WARNING

When performing preventive maintenance procedures the POWER ON/OFF switch should be placed in the OFF position and the AC input plug should be disconnected as high voltages are present in some locations within the printer when the printer is turned OFF.

PREVENTIVE MAINTENANCE

<u>ITEM</u>	<u>FREQUENCY</u>	<u>PROCEDURE</u>
External Cleaning	As Required	Clean all external surfaces using a mild detergent and a soft, clean, lint-free cloth.
Internal Inspection	Each Ribbon Change	Visually inspect interior of printer for loose wires, connectors, and hardware, chafing of cables, and badly worn or damaged parts.
Print Head and Carriage Assembly	Each Ribbon Change	After removing ribbon, use a soft-bristle brush to carefully brush dust and residue from print head and carriage assembly.
Print Head	Each Ribbon Change	Using a soft, clean, lint-free cloth gently remove all dried ink from the front of the print head.
General Cleaning	6 Months	Perform all of the above procedures. Clean the platen surface using a soft lint-free cloth. Using a vacuum cleaner with a soft brush attachment carefully vacuum interior of printer taking care not to damage printer.

PREVENTIVE MAINTENANCE (cont'd)

<u>ITEM</u>	<u>FREQUENCY</u>	<u>PROCEDURE</u>
Carriage Shafts	6 Months	Move print head to left side of printer. Apply several drops of lubricating oil to clean, lint-free cloth and lightly rub carriage shafts to remove any build-up of residue. Move print head to right side of printer and repeat procedure.
Paper Drive Roller	6 Months	Using a lint-free cloth, clean the paper drive roller and plate bushings. After cleaning, apply one drop of light lubricating oil to both paper roller end plate bushings. Cycle the paper roller using the thumbwheels to allow the oil to seep into the bushings.

TROUBLESHOOTING

The troubleshooting chart below lists some malfunctions which may occur, the probable causes, and the remedies. If after performing the remedies indicated, the equipment remains inoperative, the equipment should be serviced by qualified service personnel. Note that attempts to repair the printer which result in further damage to the printer void the warranty.

WARNING

When performing troubleshooting procedures, the POWER ON/OFF switch should be placed in the OFF position and the AC input plug should be disconnected as high voltages are present in some locations within the printer when the printer is turned OFF.

TROUBLESHOOTING CHART

<u>TROUBLE</u>	<u>PROBABLE CAUSE</u>	<u>REMEDY</u>
Print too light.	Print head release lever open or partially open.	Rotate print head release lever clockwise to normal printing position.
	Worn or defective ribbon.	Replace ribbon.
Roll Paper/Cut-sheet paper does not advance properly.	Pinch roller release lever in open position.	Pull pinch roller release lever forward to closed position.

TROUBLESHOOTING CHART (cont'd)

<u>TROUBLE</u>	<u>PROBABLE CAUSE</u>	<u>REMEDY</u>
Ribbon does not feed properly.	Ribbon twisted or im- properly loaded.	Check ribbon threading and correct as required.
	Ribbon drive rollers not engaged properly.	Open and release driven roller. Rotate driven roller clockwise to ensure proper movement of ribbon.
Printer completely inoperative.	AC input plug not connected.	Connect AC input connector to power source.
	Paper jam.	Remove power and carefully clear paper jam. Check condition of ribbon before returning power.
	Fuse F1 blown.	Check if "Power On" LED is lit by looking down through paper exit slot. If not lit, replace fuse F1 with a good fuse of the same rating.
Power applied/data sent-printer does not print.	Cable between input de- vice and printer not connected.	Check that connectors at both ends of data input cable are properly connected to mating connectors.
	ON-LINE/LOCAL switch in LOCAL position.	Place switch in ON-LINE position.

REMOVAL OF COVER ASSEMBLIES

In order to replace fuse F1 or to disable the auto line feed on carriage return function it is necessary to remove the cover assemblies. Refer to Figure 14 and proceed as follows:

1. Place POWER ON/OFF switch in OFF position and disconnect AC input plug from power source. Disconnect data input connector.
2. Remove top cover by lifting at rear edge where paper enters.
3. Unthread the ribbon from the print head carriage assembly, then take up slack in ribbon by turning ribbon driven roller knob clockwise.
4. Release the two screws at the front of the printer and the three screws at the rear of the printer using a No. 2 Phillips-head screwdriver.
5. Gradually raise the body cover until there is enough room to reach under the front of the cover.
6. Reach under the body cover and disconnect the ribbon drive motor cable connector from connector J002 on the logic PC board.
7. Keep the body cover level to prevent ribbon from unthreading and set cover to one side.
8. To reassemble printer, reverse procedure.

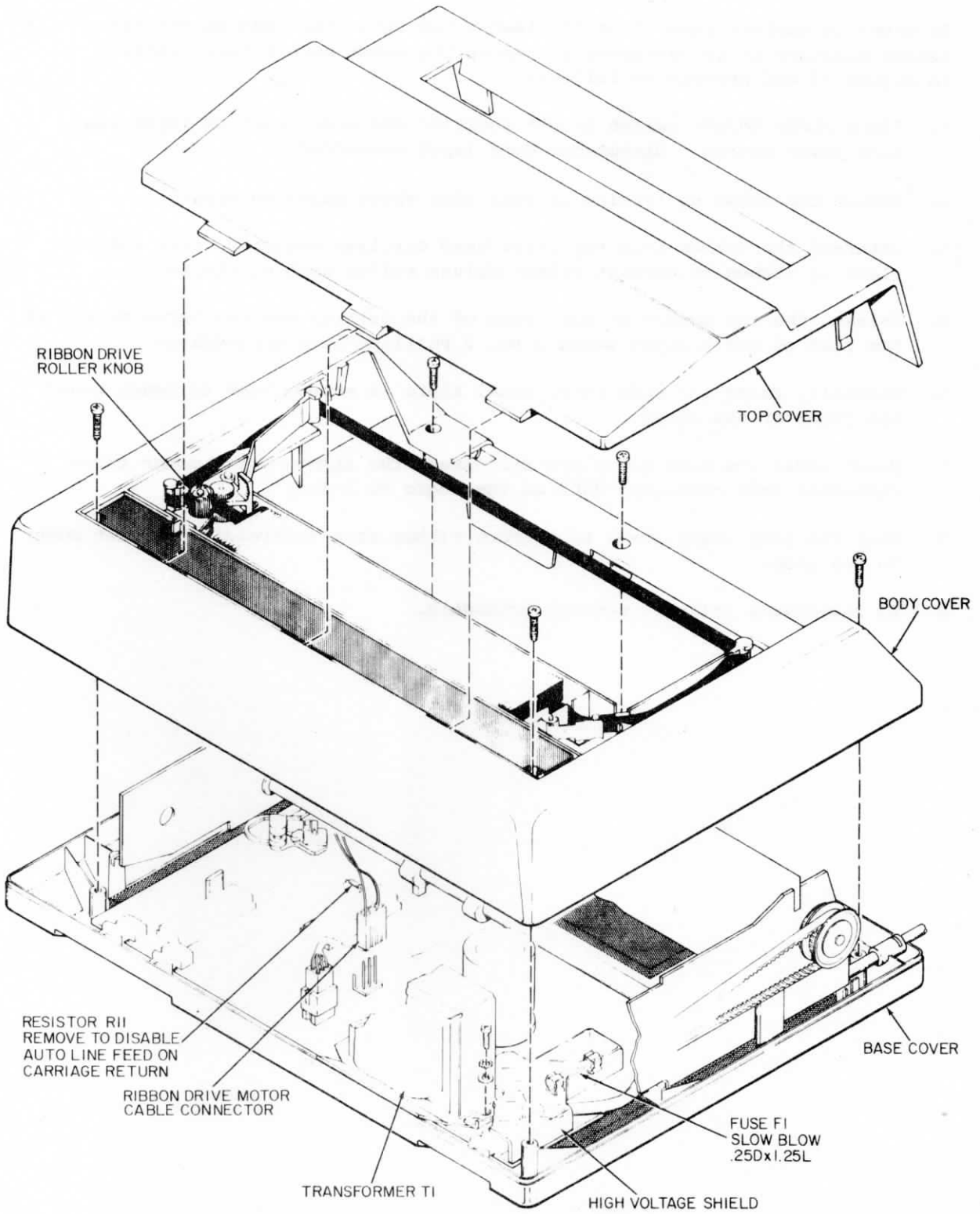

Figure 14. REMOVAL OF COVER ASSEMBLIES

FUSE REPLACEMENT

Fuse F1 is located on the forward right-hand corner of the logic P.C. board. Refer to Figure 14 and proceed as follows:

1. Remove cover assemblies to gain access to logic P.C. board mounted on the base cover (See procedure for disassembly of cover assemblies).
2. Loosen screw, located on right side of transformer using a phillips-head screwdriver.
3. Remove the clear plastic high voltage shield covering the fuse and AC input circuits.
4. Remove and replace the defective fuse with one of the same rating.
5. Reinstall the high voltage shield. Make sure that the slotted portion of the shield is under the flat washer.
6. Tighten the phillips-head screw to secure the shield and transformer.
7. Reassemble the cover assemblies.

DISABLING OF AUTO LINE FEED ON CARRIAGE RETURN

The auto line feed on carriage return function may be disabled by removing resistor R11 on the logic P.C. board. To disable this function, refer to Figure 14 and proceed as follows:

1. Remove cover assemblies to gain access to logic P.C. board mounted on base cover. (See procedure for disassembly of cover assemblies).
2. Locate resistor R11 and cut the lead that is most distant from the large IC chip, using side cutters.
3. Bend resistor upward away from P.C. board and cut second resistor lead.
4. Reassemble the cover assemblies.

The auto line feed on carriage return function may be re-enabled by installing a new resistor R11; 270 ohms, 1/4 watt. Use a 25 to 35 watt soldering iron and wicking braid or a solder sucker to remove old solder, then solder the new resistor in place. Before installing the resistor, trim and form leads so that they do not extend more than 1/8 inch through the printed circuit board.

Fold

BUSINESS REPLY MAIL
No Postage Necessary if Mailed in USA

First Class
Permit 31
Hudson, N.H.
03051

Postage will be paid by—

CENTRONICS

Data Computer Corp.
Hudson, New Hampshire 03051



ATTN: MGR. TECHNICAL PUBLICATIONS

Fold