

Heathkit Model H10 Paper Tape Reader/Punch

A Review

By Roger H. Edelson, Hardware Editor

This is not one of my normal card-of-the-month articles as I didn't build the Reader/Punch described herein. However, I have spent a reasonable amount of time with the Heathkit Reader/Punch.

The Heathkit H10 provides a reasonable cost method of reading and punching standard 8-level, 1-inch paper tape. The Reader/Punch can accommodate either fan-fold or up to a 10-inch diameter roll of oiled or unoled paper tape. The maximum reading speed is 50 characters per second, and up to 10 characters a second is the maximum punch speed.

Both the reader and punch may be operated simultaneously and yet controlled independently. The H10 has a standard TTL parallel interface and uses a photo-electric tape reader rather than electro-mechanical types to achieve reliable operation. Independent adjustment of the "1/0" threshold is provided for each channel. The tape reader transport is driven by a stepper motor in order to achieve dependable operation. An additional nice touch is a pushbutton feed switch to generate as much leader tape as desired and a pushbutton switch to permit the easy copying of other tapes.

**...the instructions are typical Heath;
an entire eighty page manual is
provided to guide you through the
construction. . .the manual provides
clear and detailed text . . .**

As I didn't build this device I can't comment directly on its construction. However, the instructions are typical Heath; an entire eighty page manual is provided to guide you through the construction. As in all Heathkits, the assembly manual provides clear and detailed text liberally sprinkled with the necessary pictures. Each step is checked off as it is completed, and scales are provided for the measurement of the hookup wires which are to be cut to the length specified in the manual. All this is standard Heath but must come as a sort of a shock to persons familiar with the rather barren fare of the standard computer kit manuals.

The Reader/Punch is divided into a number of different functional areas which makes it convenient to discuss each section separately. Figure 1 provides a full view of the schematic and will be used in the following discussions.

Reading of the paper tape is performed by a photo-Darlington transistor Q101. This device provides a high gain conversion from the light passing through the tape

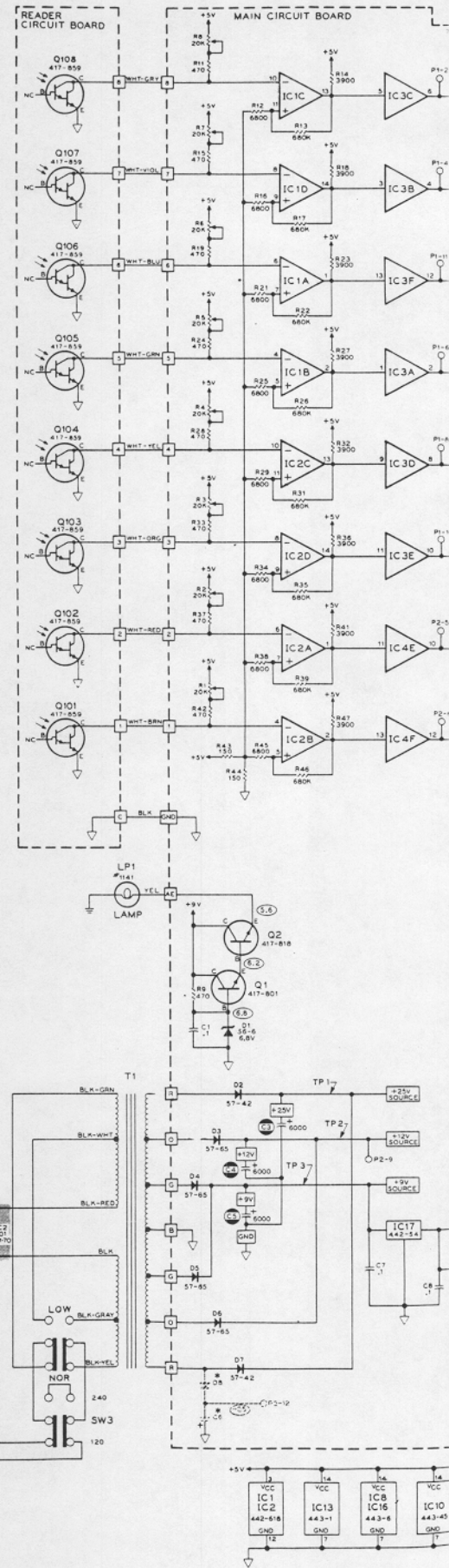

Copyright © 1977 Heath Co. All Rights Reserved

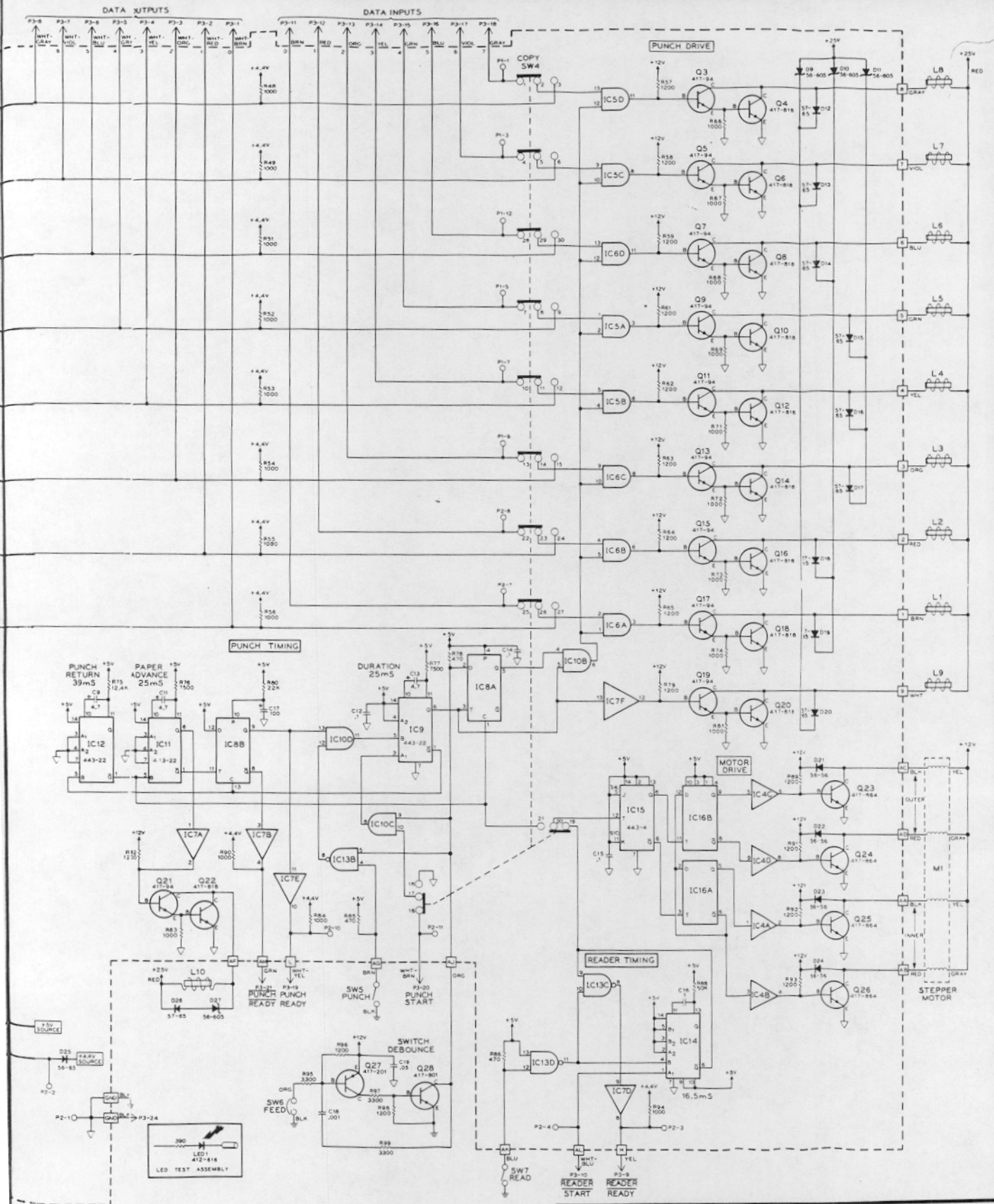

Figure 1.

- Part of 595-2000
- COMPONENT NUMBERS ARE IN THE FOLLOWING GROUPS:
 1) 99 PARTS MOUNTED ON THE CHASSIS AND MAIN CIRCUIT BOARD.
 100-199 PARTS MOUNTED ON THE READER CIRCUIT BOARD.
 - ALL RESISTORS ARE 1/2 WATT UNLESS MARKED OTHERWISE.
 RESISTOR VALUES ARE IN OHMS, K Ω , 100K, 1M, 100K, 10M.
 - ALL CAPACITORS ARE IN μ UNLESS MARKED OTHERWISE.
 - ∇ THIS SYMBOL INDICATES CIRCUIT BOARD GROUND.
 - \square THIS SYMBOL INDICATES CHASSIS GROUND.
 - THIS SYMBOL INDICATES WHERE A WIRE IS SOLDERED TO A CIRCUIT BOARD.
 - THIS SYMBOL INDICATES A CONNECTOR INSIDE CHASSIS PUG 91.
 - THIS SYMBOL INDICATES A PART THAT APPEARS TO BE IN A CIRCUIT BOARD BUT IS ACTUALLY MOUNTED ON THE CHASSIS.
 - THIS SYMBOL INDICATES A DC VOLTAGE TAKEN WITH A HIGH INPUT IMPEDANCE VOLTMETER FROM THE POINT INDICATED TO CHASSIS GROUND. VOLTAGES MAY VARY 10%.
 - PARTS IN SHADDED AREAS ARE CRITICAL FOR CONTINUED SAFETY. REPLACE THEM ONLY WITH PARTS OF THE SAME RATING OR WITH THE PROPER HEATH PARTS.
 - COPY SWITCH SW4 IS SHOWN IN THE OUT POSITION.
 - THESE PARTS ARE FOR POSSIBLE FUTURE APPLICATION.

We speak your language

And we're giving you what you want.

- a **comprehensive product line.** Hardware, assembled or kits, and software from major manufacturers. Plus books and current literature. Financing available.
- a **trained, enthusiastic staff.** We'll help you choose or design the system that's right for you. No high pressure here.
- **service when you need it.** We won't sell you something we can't keep running.

- a **brand new facility in Pennsylvania.** We'll be able to serve our South Jersey-Pennsylvania customers more efficiently now.
- a **bigger, better New Jersey store.** We've enlarged our showroom in Iselin. Now there are more displays you can try out. There's more room to stock the products you need.



The Microcomputer People.™

Computer Mart of New Jersey Computer Mart of Pennsylvania

New Jersey Store
501 Route 27
Iselin, NJ 08830
201-283-0600
Tue.-Sat. 10:00-6:00
Tue. & Thur. til 9:00

Pennsylvania Store
550 DeKalb Pike
King of Prussia, PA 19406
215-265-2580
Tue.-Thur. 11:00-9:00
Fri. & Sat. 10:00-6:00

(our only locations)

CIRCLE INQUIRY NO. 79

holes to a electrical current. This current flowing through resistors produces a voltage which is sensed by the comparator. One of the resistors is variable, thereby allowing individual adjustment of the I/O discrimination level of each channel. This technique provides a method for removing the individual differences of each channel without the need for expensive worst-case design. The comparator is designed with positive feedback to provide switching hysteresis which eliminates (or reduces) false triggering. The comparator output drives a buffer amplifier, which in turn drives the data output lines.

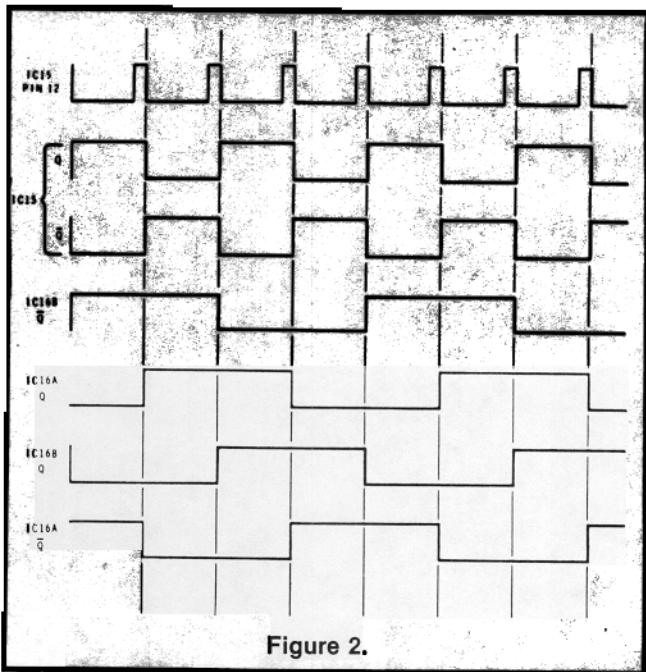

Figure 2.

A nice Heath touch is evinced by the circuitry used to supply the lamp power. Here Heath has chosen to provide a voltage controlled source using a zener diode, D1, and two transistors, Q1 and Q2. This technique provides a constant light output, necessary for reliable "hole/no hole" discrimination, and long lamp life since the lamp is protected from harmful over-voltages.

Timing for the stepper motor drive circuitry is generated by the one-shot multivibrator IC14, in conjunction with the Reader Start and Reader Ready lines. When the Read switch SW7 is pushed to ON, the 16.5 ms one-shot will be triggered if the Reader Start line is low. The \bar{Q} output of the multivibrator goes low, driving the trigger input of flip-flop IC15, part of the motor drive circuitry. At the same time, the Reader Ready line is driven high to indicate that the reader is busy.

After 16.5 ms, the one-shot times out, \bar{Q} goes high again, and the Reader Ready line is pulled low to indicate that the reader is now ready to accept another 1-to-0 transition on the Reader Start line in order to advance the tape one more hole. When the Copy switch is set to the copy position, the punch timing circuitry drives the motor timing drive circuitry directly without using the multivibrator. Since the punch always runs much slower than the maximum rate of the reader, there is no need to use the handshaking circuitry; the punch just provides a drive signal directly to the trigger input of IC15.

The motor drive circuitry takes the 16.5 ms timing pulse from the one-shot multivibrator and produces the 4-phase driving pulses required by the stepping motor. IC15 produces two output signals which are 180 degrees out of phase, and each is one half of the frequency of the input timing signal.

To better understand this circuitry, refer to the timing diagram given in Figure 2. To follow the circuit action, assume that when power is applied, the \bar{Q} outputs of

BYTE

of PALO ALTO

extensive business applications

for new low cost computer systems

DOCTORS/DENTISTS
MANUFACTURERS
BUSINESSMEN
LAWYERS/INSURANCE AGENTS
SCIENTISTS/ENGINEERS

BYTE OF PALO ALTO
2233 EL CAMINO REAL
PALO ALTO, CA 94306
(415) 327-8080

New Store Opening

475 SACRAMENTO
SAN FRANCISCO, CA 94111

of PALO ALTO

CIRCLE INQUIRY NO. 70

IC15 and IC16A are high and IC16B-Q is also high. Because the D inputs of the IC16 A&B flip-flops are tied to the Q output of IC16A, the Q output of IC16A will be driven high. This is where the timing sequence shown in the figure begins.

With the first pulse to the trigger input of IC15, the flip-flop inverts its state, and the Q output goes low and Q goes high. Because the D inputs of IC16 are high, IC16B output goes high and Q goes low. The other half of IC16, IC16A, is unaffected. The next time IC15 changes state, IC16B remains unchanged and IC16A inverts its outputs. As the input pulses to IC15 continue, the result of this action is to produce a 4-phase signal that is applied through buffers to the motor drive transistors Q23 through Q26. The diodes D21 through D24 are used to suppress the inductive voltage spikes generated by the motor windings when the drive current is terminated.

The punch solenoids are driven by Darlington transistor pairs in order to provide the high current required by the solenoid while interfacing with standard logic. Again, diodes are used to prevent inductive overvoltages from damaging the drive transistors. However, in this case, in order to shorten the punch recovery time, the diodes are clamped instead to a voltage about 20 volts above the supply. The clamp voltage is set by a zener diode. The drive for the punch is the logical AND of a punch drive timing signal (derived from IC10B - Pin 6) and the data signal from either the data input connector or the tape read circuit (if the copy switch is set for copy).

The punch solenoids are driven by Darlington transistor pairs in order to provide the high current required. . .

Three one-shot multivibrators control the punch timing. IC9 controls the duration of the punching operation, IC12 provides the time for the punches to return to their normal positions, and IC11 times the paper-advance solenoid. The multivibrators are interconnected so they will perform their timing functions in the proper sequence.

Gate IC10B is for circuit protection. Without it, when the unit is turned on, the Q output of IC8A could be high and possibly turn on all the solenoids continuously. This could blow the fuse or damage the solenoids.

When the Feed switch is pushed, the pulse is debounced by Q27 and Q28, and the output of gate IC10C goes low and starts the timing of IC9; its Q output goes high. This operates solenoid L9 (through IC7F, and Q19 and Q20) and transfers the low at the D input of IC8A to the Q output. With a low and a high at the inputs of IC10B, solenoids L1 through L8 remain off.

When the Q output of IC9 goes high, the Q output goes low. After IC9 times out, the Q output goes high again and starts IC12 and drives its Q low. This does not affect IC11 at this time, but it does clear IC8A and turns off the punch drivers.

When IC12 times out, its Q output goes high and starts IC11, driving its Q output high. This drives IC7A and transistors Q21 and Q22 to drive tape advance solenoid L10. When IC11 times out, its Q output goes high and forces a high at the Q output of IC8B, which had been cleared when IC9 started timing out. This is transferred to the Punch Ready output by IC7E. This high at pin 13 of IC10D now allows the Punch and Feed switches or a "punch start" signal at P3-19 to control the punching.

In normal operation, a transition from high to low on the "punch start" line (P3-19) will be coupled through IC10C to trigger IC9.

Stand Alone ASCII Keyboard Specification

☆ 4 SIMULTANEOUS OUTPUTS AVAILABLE: THE ONLY ONE ON THE MARKET

- 1. SERIAL TTL LEVEL
 - 2. BUFFERED 8 BIT (TRI-STATE LATCH) PARALLEL OUTPUT WITH VALID DATA SYNC PULSE AND LEVEL
 - 3. 20 MA OPTO-ISOLATED CURRENT LOOP, POLARITY INDEPENDENT
 - 4. EIA RS232C
- ☆ SINGLE +5 VOLT 300 MA (NOMINAL) POWER SUPPLY (REQUIRED)
 - ☆ INDUSTRY STANDARD 2 KEY ROLLOVER ENCODER
 - ☆ ANSI - COMPATIBLE KEY SET; FOR SLIM-LINE "HIDEAWAY" PACKAGING
 - ☆ SEGMENTED SPACE BAR ALLOWS FAST MULTIPLE-SPACING WITHOUT REPEAT KEY
 - ☆ REPEAT KEY REPEATS AT CHARACTER RATE
 - ☆ USER SELECTABLE UPPER CASE ONLY (KSR/ASR/33 REPLACEMENT) OR UPPER/LOWER CASE
 - ☆ FACTORY SET AT 110 BAUD BUT EASILY ADJUSTED BY USER TO ANY BAUD RATE FROM 110 TO 9600 BAUD
 - ☆ FLEXIBLE PARITY
 - ☆ LED INDICATOR FOR SHIFT-LOCK KEY ELIMINATES CASE UNCERTAINTY
 - ☆ 24 PIN DUAL - INLINE CONNECTOR
 - ☆ LOW PROFILE CASE (OPTIONAL) \$40.00

\$9700 ASSEMBLED AND TESTED

Plus \$3.00 handling charge. California residents add 6 1/2% sales tax.

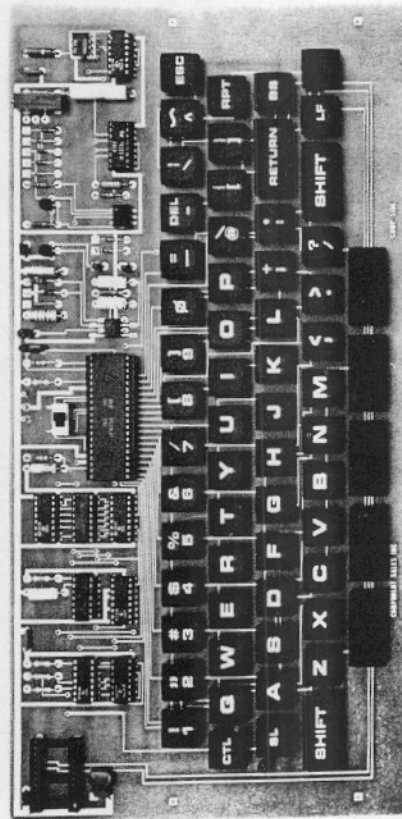

Orders accepted by phone or mail.

MASTERCHARGE ☆ VISA ☆ COD ☆ CHECK ☆ MONEY ORDER

COMPONENT SALES INC.
778-A BRANNAN, SAN FRANCISCO, CA 94103

[415] 861-1345



BASF diskettes . . .
the industry standard

100% certified at single density. Our experience indicates low error rates at 4X single density. **SATISFACTION GUARANTEED.** Return diskettes with packing list in original container within 15 days of receipt to obtain refund.

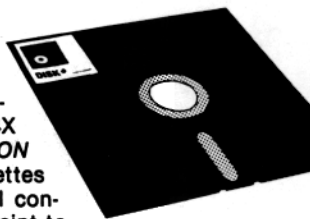

choose from the following one-side diskettes:

8 INCH: one sector (soft) or 32 sector (hard)

5 1/4 INCH: one sector; ten sector; 16 sector

Mix or match boxes of 20 diskettes to take advantage of quantity 40 or 80 VOLUME PRICING:

QTY.	AMOUNT	PRICE EACH
10	45.00	4.50
20	85.00	4.25
40	160.00	4.00
80 or more	288.00/80	3.60

TO ORDER state size, sector, and quantity. Add \$5.00 for handling. Wisconsin residents add 4% sales tax or send copy of your resale permit. Please allow three weeks for personal checks to clear. Charge and cash orders shipped in three working days.

Madison Business Systems

1863 Monroe Street
Madison, WI 53711
Phone (608) 255-2236
Open 10-6 Mon.-Sat.



CIRCLE INQUIRY NO. 87

The power supply is relatively standard with a single three-terminal regulator providing the 5 volt logic power. Heath has provided their normal nice touches by having a 120/240 selector switch — something not found on most home computer equipment. Additionally, in order to optimize the punch drive circuits, a switch is provided to adjust the reader/punch power supply for either low or normal line voltage conditions.

The mechanical design is typically Heathkit, generally effective and buildable by the home hobbyist. The major problem would appear to be the necessary compromise between kitability and cost and precision. The punch suffers the most from this problem with the major symptom being a long, almost tortuous, path from the back of the unit to the punch itself. While the long channel serves to provide registration for the paper tape, the whole process of loading a tape for punching is invisible to the user. In fact, the tape is never seen from the time it is placed in the beginning of the channel at the bottom rear of the unit until it emerges (as if by magic) from the slot at the front. Also, the triangular protrusion used to help tear the paper tape does not work very well because of the slope of the unit front. It leaves very ragged edges which makes it difficult to inset the tape into the reader.

On the other hand, the reader is nicely designed. The long channel is much easier to use, and there is a nice pin strategically placed to hold fan-fold tape. The reader is easy to use and would appear to be highly reliable. The punch mechanism and the solenoid drivers are nicely set up and would appear to provide trouble free service.

On the balance, the Heathkit H10 Paper Tape Reader/Punch is a reasonable cost means of adding reliable paper tape capability to your system; it's not an ASR 33, but then its not \$1,500 either. □

the **BYTE SHOPS** of South Florida

Our experience has proven the SOL-20 to be among the very best computers. So we confidently offer this fine system, either kit or assembled, along with compatible peripherals and operating software.

PERIPHERALS

- North Star MICRO-DISK
- Centronics 700 Series Printers
- Micromation Disk System

SOFTWARE

- Powerful Word Processor for SOL on North Star Disk.
- Inventory Control
- New business packages coming

Proudly Feature **SOL-20**



Continuing service and assistance, and a complete line of books and magazines are offered at both locations, to assure you that your system, purchased from one of the **BYTE SHOPS** of South Florida, will keep giving you excellent performance.

2 Locations open 10-6 Monday through Friday, Saturday 10-2

BYTE SHOP OF MIAMI
7825 Bird Road, Miami, FL 33155
DIAL (305) 264-BYTE

BYTE SHOP OF FORT LAUDERDALE
1044 E. Oakland Park Blvd., Ft. Lauderdale, FL 33334
DIAL (305) 561-BYTE