

# MICRO<sup>TM</sup>

Advancing Computer Knowledge

## New Wave of Computers

 **ATARI 1200XL**

 **APPLE IIe**

 **C64...**

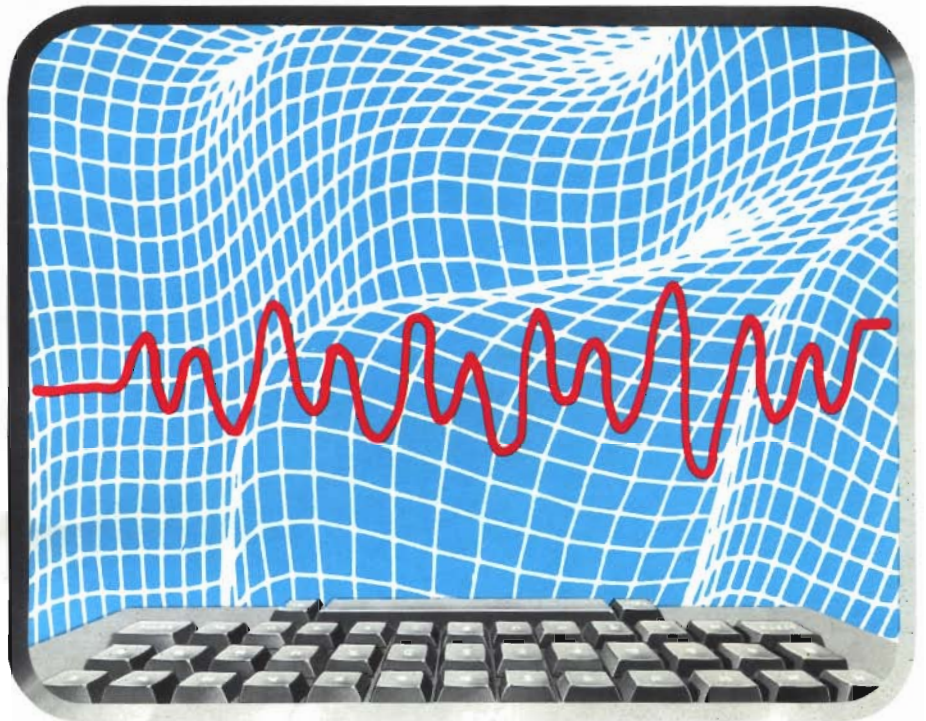

**Color Computer Clock**

**Graphics on the APPLE and PET**



**In this month's Learning Center:**

**File Management for Commodore Computers**

**Breakup: An Animation Game**

**for APPLE and Commodore ...**

# MAGIC MEMORY

## Will Remember Everything You

Imagine a system that would record all the wonderful, valuable information you have assimilated onto a single tiny disk. (No more scattered bits of paper, business cards, etc.) Imagine the same system giving you a typed sheet you could put into a notebook or print out for a party and instantly change, or add to, at a moments notice. Imagine cross-referencing to suit both your business needs and personal desires so that all your data was organized into one little black book! On top of all this — imagine having fun putting it together.

MAGIC MEMORY™ is built for the computer rookie. Everyone can relate to MAGIC MEMORY™ because its form is familiar. It looks like an address book but it's not. It's *more*. Like the address book, MAGIC MEMORY™ presents an A thru Z index tabulation on the right edge of the video display. The user simply selects a tab and the book is opened to the proper page(s). A second set of tabs are available that can be labeled by the user (i.e., companies, deals, wife's birthdays, lists, wine shops, etc.) Yet MAGIC MEMORY™ is



"Imagine" no more. ARTSCI, INC. proudly announces MAGIC MEMORY™, the complete advanced database system. MAGIC MEMORY is made to simplify the information storage process.

The typical first-time computer user has no human experience that will help him to relate to a computer's methods of handling information. Therefore his learning ability is hampered and remains so for many hours of use, UNLESS the computer has been designed to run simply.



much more versatile than the old paper address book. This system can instantly add or delete information, sort alphabetically, and transfer data to other locations in the book.

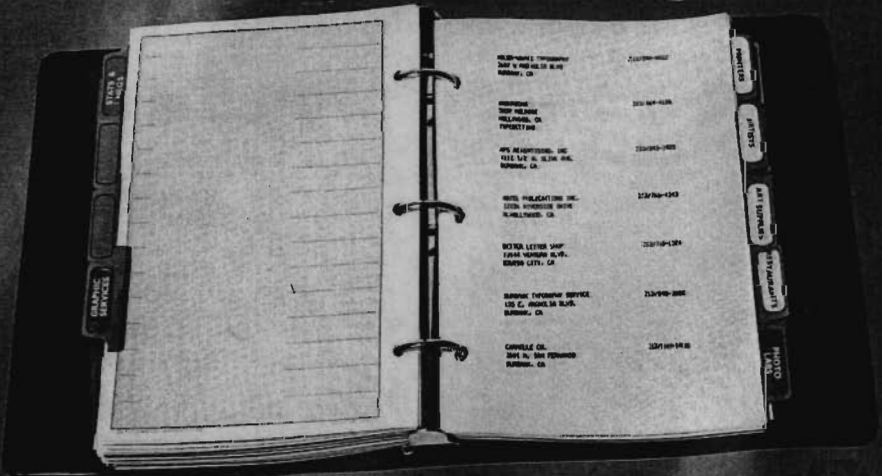

One of the features in the print section of MAGIC MEMORY™ is the ability to print out any or all of the address book.



or any of its special sections. A window binder is included in the package for the address or special sections pages. Lists are also available.

MAGIC MEMORY™ will present a screen with information available to anyone. It is only information that originates from your files.

MAGIC MEMORY™ is designed to be used in a home or office and still be portable. It can be used in a file cabinet. The system will fit into 5 1/4" floppy disks. The 70-column display requires no additional hardware.

MAGIC MEMORY™ will retail for \$39.95. Call 213/985-5763 to see your imagination to build your own additional files. MAGIC MEMORY™ is available at ATTENTION.

213/985-5763  
5547 Satsuma Avenue  
North Hollywood, Ca 91601

SYSTEM DESIGN, SAGE IV

# Meet The New Giant Of The Microcomputer Industry. All 4.8 x 12.5 x 16.75" Of It.

The challenge was to create a computer having room for a megabyte of RAM, a built-in Winchester with floppy backup, and the ability to perform 2,000,000 instructions per second.

A small miracle, in other words.

And small is exactly what it turned out to be. In fact, the 16-bit Sage™ IV, including all of the above attributes, takes up less than 1/2 cubic foot.

What makes such a breakthrough possible? System design.

It took the latest 64K dynamic RAMs and the Motorola 68000 processor technology, plus Winchester technology. And it took a highly integrated, closely packed, low power, high speed design incorporating a proprietary bus.

Now the Sage™ IV is ready for you. Actually, you can choose from three different Sage™ IV models to meet your exact needs—configurations with a 5 megabyte

Winchester plus 640K floppy right on up to a combination of four fixed or removable Winchesters plus one or two floppies (200 megabytes of disk capacity in all).

Because of the Sage™ IV's no-compromise system design you can load a 16K program in 1/10 second from Winchester disk.

What's more, there are over 120 sources for existing popular programs for the Sage™ IV. The incredible p-System operating system, standard on every Sage™ IV converts software that was originally written for 8-bit computers in Pascal, BASIC and Fortran. Optionally, CP/M-68K Modula, and HyperForth are also available.

Better yet, our small miracles come with prices to match.

So give us a call or write today for more Sage™ IV information and the name of your nearest dealer.

### Western United States

Sage Computer Technology,  
35 North Edison Way, #4, Reno,  
NV 89502 (702) 322-6868.

### Eastern United States

Sage Computer Technology,  
15 New England Executive Park  
Suite 120, Burlington, MA 01803  
(617) 229-6868

### In UK

TDI LTD, 29 Alma Vale Road,  
Clifton, Bristol BS8-2HL  
Tel: (0272) 742796.  
Tx: 444 653 Advice G

### In Germany

MM Computer, GmbH,  
Hallwanger Str. 59, 8210 Prien  
Tel: 08051/3074  
Tx: 525 400 mrrco-d



Sage trademark of Sage Computer Technology  
CP/M, trademark of Digital Research  
Modula, trademark of Molson Systems  
Hyper-Forth, trademark of Forthright Engineering  
p-System, trademark of UC Regents



# PRINTER OPTIMIZER



Why buy a mere "spooler" when you can have THE PRINTER OPTIMIZER?

- \* 64k to 256k spooling buffer
- \* adapts different brands - can mix Serial and Parallel
- \* character conversion: 1 to 1, 1 to many, many to 1, ignore
- \* pushbutton automated access to your printer's various type styles and printing modes
- \* several ways to PAUSE printing
- \* access any character, graphic design or printer "trick" from any program at any time
- \* special features for use as a MODEM buffer

## ETI<sup>2</sup>

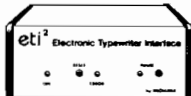

The cost effective alternative. Converts IBM, Adler/Royal, Olympia and other Electronic Typewriters into letter quality printers.

- \* 2K memory buffer
- \* access all typewriter characters and automated features
- \* Serial or Parallel versions
- \* Many proprietary features and commands insure compatibility with your system and software
- \* Typesetting capability!

## PETI<sup>2</sup>



Super low cost adaptor for new inexpensive portable Electronic Typewriters can yield typewriter and letter quality printer combination for around \$500 total!

- \* perfect for "personal use"
- \* easy "plug-in" Parallel connection to most computers
- \* compatible with popular word processing programs

## APPLIED CREATIVE TECHNOLOGY INC.

2723 Avenue E East, Suite 717  
Arlington, Texas 76011  
(817)-261-6905  
(800)-433-5373

# MICRO<sup>TM</sup>

## Highlights

### The New Wave of Computers

"Great waves looked over others coming in...." Robert Frost was speaking of the Pacific Ocean; we are speaking of the many new computer products that are flooding the market. A few years ago it was a simple matter to go out and buy a home computer — you didn't have much selection. Today you must choose from computers that fit nearly any situation, any pocketbook, and any kind of computerist — from novice to highly technical.

Once you have decided which computer is right for you (taking into consideration memory requirements, load and save capabilities, editing functions, etc.), then you should become knowledgeable about add-on boards, modems, printers, hardware, and software that is available. The May issue of MICRO is designed to provide you with information about the tide of new products flowing into the market today and what you can expect in the near future.

Paul Swanson opens our feature section with a comparison of the Atari 1200XL, 400, and 800 in "The Atari 1200XL" (pg. 20). In "Microprocessors for Your Apple II" (pg. 26), Phil Daley and John Hedderman compare add-on boards for the Apple II that increase capabilities, provide new features, and teach new languages. "New Commodores" (pg. 30) by Loren Wright is a discussion of Commodore's new product line, including the VIC-20, Commodore 64, and a computer soon to appear on the market — the C 128/80. Keith Roberson asks "Is 16 Bits the Solution?" (pg. 32). The 16-bit microprocessor has made a significant impact on the imagination of microprocessor users. However, Keith believes 8-bit technology can be expected to have a long and active life in the small computer marketplace.

### Programming Aids

This month we provide you with seven programming aids. Werner Kolbe shows you how to write up to four times more numerical data on a CBM disk using the computer's internal binary format instead of ASCII strings. Read "Get More Data on Your CBM Disk" (pg. 38). Randall Hyde discusses several methods for passing data to and

from assembly-language subroutines. He uses examples for the 6502, 6809, 68000, and 16032 microprocessors. See "Parameter Passing in Assembly Language" (pg. 40). John Steiner has written a subroutine that adds a real-time clock and date function to your programs. Learn how to use TIME\$/SUB in "Real-time Clock for the Color Computer" (pg. 50).

"&GET" by David Dice (pg. 52) is a machine-language program to allow customized input routines; and "Modifying and Using MAE" (pg. 56), by F. Arthur Cochrane, describes how to modify the MAE assembler to enable output to an ASCII printer and listing output to a disk file. Joe Hootman continues his series with a discussion of miscellaneous instructions implemented by the 68000. See "68000 Instructions" (pg. 58). And finally, Jim Strasma continues his series "It's All Relative, Part 5: Printing Commodore File Data" (pg. 62) with a discussion on formatting and printing data from Commodore relative disk files.

### Graphics and Printers

The graphics section includes several informative articles regarding printers. You can learn how to print Apple II's hi-res graphics screens on Okidata Microline 80's printer; use an assembly-language program for the Apple II that automatically produces top and bottom margins on each page of printer output, address a second PET as an IEEE device 4. Also learn to print AIM listings the full width of your printer with a machine-language printer driver, and to interface an OSI Superboard II to a Radio Shack Quick Printer II.

### The Learning Center

In the Learning Center this month you will study PEEKs and POKEs in "Breakup" (pg. 71) by Loren Wright and Phil Daley. "Breakup" is a simple animation display game that includes a ball and brick wall and tests for collisions. Brian Zupke's "Addressfile" (pg. 76) is an easy tape-based file-management system for the VIC-20 and other Commodore computers. You can store names, addresses, phone numbers, and memos in a cassette file.

We continue to provide you with a wealth of information in our on-going columns. Be sure to read PET Vet, From Here to Atari, Coco Bits, and Interface Clinic, as well as our regular departments. MICRO keeps you on the crest of the wave of new computers.

MICRO

*The* PEACH™

LN

GR

## EMI-RFI FILTERED AC SURGE PROTECTOR

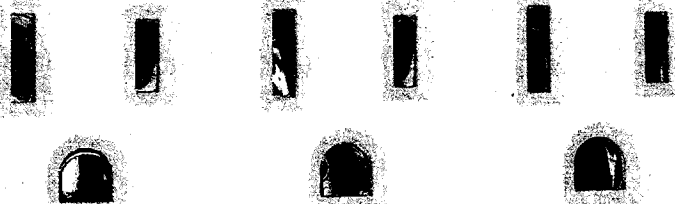

In addition to a crop of surge protectors. It is this "spikes" or "surges" that can damage your equipment. The "hash" or "noise" produced by modern electronics while they are operating simultaneously can also produce "jazz" or "noise" - Magnetic Interference (EMI) and Radio Frequency Interference (RFI).

The increasing density and scope of modern electronics means that each microprocessor element must perform its function with signals of any kind that may or reduce the intelligibility of the "Hash" - electrical noise produced by opening and closing of switches or

with the "spikes" or "surges" that can damage your equipment. The "hash" or "noise" produced by modern electronics while they are operating simultaneously can also produce "jazz" or "noise" - Magnetic Interference (EMI) and Radio Frequency Interference (RFI).

The increasing density and scope of modern electronics means that each microprocessor element must perform its function with signals of any kind that may or reduce the intelligibility of the "Hash" - electrical noise produced by opening and closing of switches or

with the "spikes" or "surges" that can damage your equipment. The "hash" or "noise" produced by modern electronics while they are operating simultaneously can also produce "jazz" or "noise" - Magnetic Interference (EMI) and Radio Frequency Interference (RFI).

The increasing density and scope of modern electronics means that each microprocessor element must perform its function with signals of any kind that may or reduce the intelligibility of the "Hash" - electrical noise produced by opening and closing of switches or



# MICRO™

Advancing Computer Knowledge

MICRO  
P.O. Box 6502  
Amherst, NH 03031  
(603) 889-4330

**Managing Editor**  
Marjorie Morse

**Technical Editors**  
Phil Daley  
Loren Wright

**Programming**  
John Hedderman

**Editorial**  
Emmalyn H. Bentley  
Maureen Dube

**Contributing Editors**  
Cornelis Bongers  
Dave Malmberg  
John Steiner  
Jim Strasma  
Paul Swanson  
Richard Vile

**Production**  
Helen Bergeron

**Advertising**  
Sales Manager—Bob Mackintosh  
Paula Kramer  
Admin. Assist.—Dawn Blute

**Dealer Sales**  
Sales Manager—Kathie Maloof  
Linda Hensdill

**Circulation**  
Carol A. Stark  
Cindy Schalk

**Accounting**  
Donna M. Tripp

**President**  
Robert M. Tripp  
**Publisher**  
John G. Grow

**Associate Publisher/  
Circulation Manager**  
Nancy Lapointe

MICRO is published monthly by: MICRO, Amherst, NH 03031. Second Class postage paid at: Amherst, NH 03031 and additional mailing offices. USPS Publication Number: 483470. ISSN: 0271-9002. Send subscriptions, change of address, USPS Form 3579, requests for back issues and all other fulfillment questions to MICRO, 10 Northern Blvd., P.O. Box 6502, Amherst, NH 03031, or call (603) 889-4330, Telex: 955329 TLX SRVC, 800-227-1617. *Subscription rates (per year):* U.S. \$24.00, \$42.00 / 2 yr. Foreign surface mail \$27.00. Air mail: Europe \$42.00; Mexico, Central America, Middle East, North Africa, Central Africa \$48.00; South America, South Africa, Far East, Australasia, New Zealand \$72.00. Copyright © 1982 by MICRO. All Rights Reserved.



## New Wave of Computers

- 20 **The ATARI 1200XL** ..... Paul S. Swanson  
A comparison of the ATARI 1200XL, 800, and 400 computers
- 24 **Microprocessors for Your APPLE II** ..... Phil Daley/John Hedderman  
A comparison of add-on boards for the APPLE II
- 30 **COMMODORE New Wave** ..... Loren Wright  
A discussion of COMMODORE's new product line
- 32 **Is 16 Bits the Solution?** ..... Keith Roberson  
Can 8-bit technology survive in the small computer market?

## PROGRAMMING AIDS

- 38 **Get More Data on Your CBM Disk** ..... Werner Kolbe  
Write up to four times more numerical data on disk using binary format
- 40 **Parameter Passing in Assembly Language, Part I** ..... Randall Hyde  
Pass data to and from assembly-language subroutines
- 50 **Real-time Clock for the Color Computer** ..... John Steiner  
Add a real-time clock and date function to your programs
- 52 **&GET on the APPLE** ..... David Dice  
A machine-language program to allow customized input routines
- 56 **Modifying and Using MAE on the PET** ..... F. Arthur Cochrane  
Modifications allow output to an ASCII printer and listing output to a disk file
- 58 **68000 Instructions** ..... Joe Hootman  
Miscellaneous instructions implemented on the 68000
- 61 **It's All Relative, Part 5: Printing COMMODORE File Data** ..... Jim Strasma  
How to format and print data from COMMODORE relative disk files

*New computers  
change the nature of  
the microcomputer  
industry.*

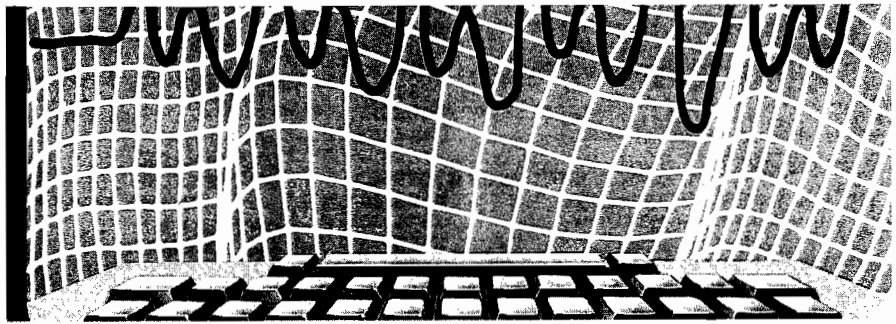

## THE LEARNING CENTER



- 73 **Breakup** ..... *Loren Wright/Phil Daley*  
A simple animation game that demonstrates PEEKs and POKEs
- 76 **Addressfile** ..... *Brian Zupke*  
A file-management system for the VIC-20 and other  
COMMODORE computers

## GRAPHICS

- 80 **APPLE Graphics for  
Okidata Microline 80: Revisited** ..... *Gary Little*  
Print APPLE II hi-res graphics screens on an  
Okidata Microline 80 printer
- 84 **A Universal Printer Pager  
for APPLE** ..... *C. Anthony Ray*  
Automatically produce top and bottom margins on each page  
of printer output
- 87 **Second PET as Soft Printer** ..... *Hans Hoogstraat*  
Address a second PET as IEEE device 4
- 91 **MULTIC — A Multi-Column Print  
for AIM** ..... *Joel Swank*  
Print AIM listings the full width of your printer
- 99 **Superboard II/Quick Printer II** ..... *Ken Benson*  
An inexpensive way to interface the OSI Superboard II  
to a RS Quick Printer II

## COLUMNS

- 12 **PET VET** ..... *Loren Wright*  
LOAD-and-RUN programming
- 16 **From Here to Atari** ..... *Paul S. Swanson*  
Drawing geometric shapes
- 17 **CoCo Bits** ..... *John Steiner*  
A look at the TDP 100, modems, and service manuals
- 102 **Interface Clinic** ..... *Ralph Tenny*  
Experiments in interfacing

## DEPARTMENTS

- 2 May Highlights  
6 Letters/Updates/Microbes  
10 Editorial  
105 Annual Index  
110 Reviews in Brief  
115 Software Catalog  
119 Data Sheet  
122 Hardware Catalog  
124 6809 Bibliography  
127 Next Month in MICRO  
128 Advertiser's Index

*Apple II.....page 24*



*Atari 1200XL.....page 21*



*Commodore.....page 31*

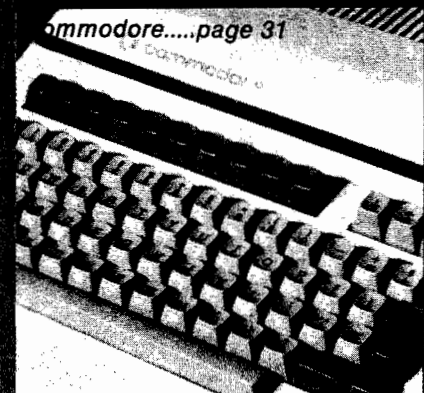

**NEW LOWER PRICES**

**ASHTON TATE**  
 dBASE II ..... \$489.00  
 BOTTOM LINE STRATEGIST ..... 279.00  
 C.I.TOH  
 PROWRITER PARALLEL ..... 399.00  
 F-10 55 ..... 1799.00  
 F-10 PARRALLEL/SERIAL ..... 1359.00  
 GRAPPLER INTERFACE ..... 125.00  
 PROWRITER II ..... 789.00  
**CALIFORNIA COMPUTER SYSTEMS**  
 ASYNCHRONOUS INTERFACE ..... \$129.00  
 SYNCHRONOUS INTERFACE ..... 149.00  
 CALENDAR CLOCK ..... 105.00  
 RS232 INTERFACE ..... 124.00  
 PROGRAMMABLE TIMER FOR APPLE...99.00  
**COMSHARE TARGET MARKETING**  
 PLANNER CALC ..... \$79.00  
 TARGET FINANCIAL MODELING ..... 249.00  
**CONTINENTAL SOFTWARE**  
 HOME ACCOUNTANT FOR APPLE...\$59.00  
 HOME ACCOUNTANT FOR IBM ..... 109.00  
**DICTRONICS, INC.**  
 RANDOM HOUSE ELECT. THESAURUS\$129.00  
 PROOF READER ..... 50.00  
**EAGLE**  
 MONEY DECISIONS ..... \$99.00  
**FORCE II**  
 MATH \* ..... \$89.00  
**FOX & GELLER**  
 dUTIL ..... \$68.00  
 QUICKCODE FOR dBASE II ..... 219.00  
 QUICKSCREEN ..... 129.00

**INTEGRAL DATA SYSTEMS**  
 IDS MICROPRISM 480 PRINTER . . . \$589.00  
 IDS PRISM-132 PRINTER . . . 1279.00  
 IDS PRISM-80 PRINTER . . . 999.00  
**INTERACTIVE STRUCTURES**  
 PKASSO ..... \$135.00  
**INNOVATIVE SOFTWARE, INC.**  
 TIM III ..... \$359.00  
 GRAPHMAGIC ..... 69.00  
 MATHEMAGIC ..... 69.00  
**INFORMATION UNLIMITED SYSTEMS**  
 EASYFILER ..... \$349.00  
 EASYSPELLER ..... 159.00  
 EASYWRITER II ..... 279.00  
**MAXELL**  
 FD-1 or FH-1-32 (8" SINGLE SIDED) . . . \$39.00  
 FD-2 (8" DOUBLE SIDED) . . . 49.00  
 MD-1 or MH-1 (5 1/4" SINGLE SIDED) . . . 31.00  
 MD-2 or MH-2 (5 1/4" DOUBLE SIDED) . . . 48.00  
**MICROPRO**  
 CALCSTAR ..... \$99.00  
 DATASTAR ..... 165.00  
 MAILMERGE ..... 149.00  
 WORDSTAR ..... 279.00  
 WORDSTAR/MAILMERGE ..... 349.00  
**MICROSOFT**  
 128K RAM FOR IBM PC ..... \$389.00  
 BASIC COMPILER FOR APPLE II . . . 289.00  
 128K RAMCARD ..... 389.00  
 192K RAMCARD ..... 519.00  
 256K RAMCARD ..... 659.00  
 64K RAMCARD ..... 259.00  
 MICROSOFT Z80 PREMIUM PACK . 489.00  
 MICROSOFT Z80 SOFTCARD . . . 249.00  
 MULTIPLAN ..... 199.00  
 TASC APPLESOFT COMPILER . . . 129.00  
**NORTH AMERICAN BUSINESS SYSTEMS**  
 THE ANSWER ..... \$229.00  
**PEACHTREE**  
 ACCOUNTS PAYABLE ..... CALL  
 ACCOUNTS RECEIVABLE ..... CALL  
 GENERAL LEDGER ..... CALL  
 INVENTORY ..... CALL  
 PAYROLL ..... CALL  
 SALES INVOICING ..... CALL  
**PERFECT SOFTWARE**  
 PERFECT CALC ..... \$139.00  
 PERFECT FILER ..... 199.00  
 PERFECT SPELLER ..... 139.00  
 PERFECT WRITER ..... 199.00  
**QUADRAM**  
 128K MEMORY EXPANSION . . . \$380.00  
 192K MEMORY EXPANSION . . . 475.00  
 64K MEMORY EXPANSION . . . 280.00  
 64K MEMOY UPGRADE . . . 129.00  
 MICROFAZERS ALL MODELS . . . CALL  
 QUADBOARD 64K ..... 459.00  
 QUADBOARD 128K ..... 599.00  
 QUADBOARD 192K ..... 699.00  
 QUADBOARD 256K ..... 779.00  
**SMITH-CORONA**  
 CONTROLLER FOR ELITE I . . . \$99.00  
 RANA ELITE I ..... 299.00  
 RANA ELITE II ..... 465.00  
 RANA ELITE III ..... 599.00  
**SORCIM**  
 SMITH-CORONA TP-1 ..... \$599.00  
 SUPERCALC BY SORCIM . . . \$219.00  
 SPELLGUARD ..... 189.00

**CALL TOLL-FREE  
 1-800-523-9511  
 IN PENNSYLVANIA  
 1-215-868-8219**

**T/MAKER COMPANY**  
 T/MAKER III ..... \$199.00  
**VIDEX**  
 ENHANCER II ..... 129.00  
 VIDEX KEYBOARD ENHANCER . . . 129.00  
 VIDEX VIDEOTERM FOR APPLE II . . 269.00  
**VISICORP**  
 DESKTOP PLAN APPLE II . . . \$179.00  
 DESKTOP PLAN IBM ..... 228.00  
 VISICALC ..... 179.00  
 VISICALC ADVANCED VERSION . . . CALL  
 VISICALC BUSINESS FORECASTING . 89.00  
 VISIFILE APPLE II/IBM . . . CALL  
 VISILINK ..... 184.00  
 VISIPILOT FOR APPLE ..... 159.00  
 VISITREND/VISIPILOT . . . 228.00

IBM IS A TRADEMARK OF INTERNATIONAL BUSINESS MACHINE,  
 APPLE IS A REGISTERED TRADEMARK OF APPLE COMPUTERS,  
 INC., CROSSTALK IS A TRADEMARK OF MICROSTUFF, INFOSTAR  
 IS A TRADEMARK OF MICROPRO. PRICES, SPECIFICATIONS  
 AND AVAILABILITY SUBJECT TO CHANGE WITHOUT NOTICE.  
 NOT ALL PROGRAMS AVAILABLE IN ALL FORMATS. PLEASE  
 CALL FOR ADDITIONAL PRODUCT INFORMATION.

MICROHOUSE  
 P.O. Box 499 / 1444 Linden Street  
 Department 302  
 Bethlehem, PA 18016  
 Dealers inquiries welcome!

**MICROHOUSE™**

**YOUR MICRO-COMPUTER PEOPLE**



# PUT PRICES IN CHECK

CARTRIDGE RIBBONS FOR  
**APPLE PRINTERS**  
 NEC 8023A  
 C. ITOH PROWRITER

**\$9.95** EA. **\$107.46** DOZ.

CARTRIDGE RIBBONS FOR  
**EPSON**  
**MX-80 MX-100**

**\$6.99** EA **\$11.95** EA  
**\$86.29** EA **\$129.06** DOZ

**MAXELL**  
**DISKETTES**  
 5 1/4" SINGLE SIDE  
 DUAL DENSITY  
 MD-1

**\$29.90** 10 PACK

**INNOVATIVE**  
**CONCEPTS**  
**FLIP'N'FILE**  
 DISC STORAGE BOX  
 HOLDS UP TO 60 DISKETTES

5 1/4" 8"

**\$24.95** EA **\$29.95** EA

RIBBONS FOR  
**IDS PRINTERS**

EA DOZ.

440 **\$2.77** **\$29.92**  
 PAPER TIGER **\$6.95** **\$75.06**  
 MICROPRISM **\$7.99** **\$86.29**  
 PRISM **10.95** **118.25**

**DISKETTE**  
**STORAGE**  
**BOXES**  
 5 1/4" — BLUE OR BEIGE

**\$2.49** EA.

DUAL SPOOL RIBBONS FOR  
**OKIDATA**  
**PRINTERS**

80, 82, 83 EA DOZ  
 92, 93 **\$2.77** **\$29.92**  
 84 **\$5.99** **\$64.69**

**MEMOREX**  
**DISKETTES**  
 5 1/4" SINGLE SIDE - DUAL DENSITY

**\$24.99** 10 PACK

**COLOR-**  
**CODER**  
 LIBRARY CASE SET  
 CONTAINS 5 BRIGHT COLORS

5 1/4" 8"

**\$19.95** SET OF 5 **\$23.95** SET OF 8

**ANTI-STATIC**  
**SPRAY**  
 FULL QUART SIZE  
 WITH DISPENSER

**\$6.95** QT.  
**\$19.95** 1 GALLON REFILL

CARTRIDGE RIBBONS FOR  
**COMREX**  
**DAISYWRITER 2000**

**\$2.49** EA **\$26.89** DOZ

**LABEL**  
**SPECIAL**

**\$2.99** / K  
 (5K MIN)

1 ACROSS 3 x 15/16 CONTINUOUS LABELS

**MOST RIBBONS AVAILABLE IN COLORS TOO!**  
 CALL OR WRITE FOR OUR SUPPLIES CATALOGUE  
 ON ORDERS UNDER \$14.00 PLEASE ADD \$3.00 FOR SHIPPING  
 MINIMUM RIBBON ORDER \$30.00 OR 1 DOZEN



**Check-Mate**™

TOLL FREE 800-343-7706  
 IN MASS 617-963-7694  
 PHONES OPEN 9AM-7PM EASTERN TIME

51 DIAUTO DR P.O. BOX 103  
 RANDOLPH, MA 02368

MASS RESIDENTS  
 ADD 5% SALES TAX

Circle No. 6



**Computer Case Company**

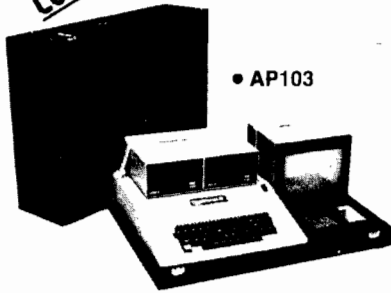

• AP103

Attache-style cases for carrying and protecting your complete computer set-up. Accommodates equipment in a fully operational configuration. Never a need to remove equipment from case. Simply remove lid, connect power, and operate.

AP101	Apple II with Single Drive	\$109
AP102	Apple II with Two Disk Drives	119
AP103	Apple II, 9 Inch Monitor & Two Drives	129
AP104	Apple III, Two Drives & Silentye Printer	139
AP105	13" Monitor with Accessories	99
AP106	AMDEK Color Monitor	119
RS201	TRS-80 Model I, Expansion Unit & Drives	109
RS204	TRS-80 Model III	129
AT301	ATARI Computers with Peripherals	109
P402	Centronics 730/737 & Radio Shack Printer	89
P403	Epson MX70/80 or Microline 82A	89
P404	Epson MX100 Printer	99
P405	IDS 560 or Prism 132 Printer	109
P406	Starwriter/Printmaster F-10 Printer	119
P407	Okidata Microline 83A or 84 Printer	99
P408	Prowriter 2 Printer	99
P409	Prowriter (Apple Dot Matrix) Printer	89
IB501	IBM Personal Computer	129
IB502	IBM Monitor	99
HP601	HP41 with Accessories	99
CM703	Commodore Model 64 with Drives	119
CM704	Commodore Model 64 with Dataset	109
NS010	North Star Advantage	139
CC80	Matching Attache Case (5")	85
CC90	Matching Attache Case (3")	75
CC91	Matching Accessory Case	95
CC92	5.25" Diskette Case	49

**Computer Case Company**

5650 Indian Mound Court  
Columbus, Ohio 43213  
(614) 868-9464

**CALL TOLL FREE**  
**800-848-7548**



Dear Editor:

Mr. Tripp and Mr. Daley did a fine job of outlining two strongly contrasting viewpoints regarding BASIC in the February 1983 dual editorial. I would like to express my complete agreement with both viewpoints, with one reservation.

Mr. Tripp's critique of BASIC is not a critique of BASIC at all. It is a critique of a particular implementation of BASIC, most likely Microsoft BASIC. Every complaint he outlines can be fixed in a properly implemented BASIC, and some of the complaints *have* been fixed in some implementations.

For instance, I took delivery of my personal Wang 2200 in November 1972. Wang 2200 BASIC does indeed make effective use of disk facilities (at first only hard disks were supported because floppy disks had not yet been invented!). Since I also own a CBM 8032/8050 combination and several Apple IIs it pains me considerably when I contemplate the exceptionally poor DOSes these machines have.

The Wang also has superb string-handling facilities and has the ability to translate back and forth between decimal and hex. There is never any garbage collection with Wang strings, and binary object code can be loaded and manipulated as string arrays since both formatted and unformatted string arrays are allowed.

Mr. Tripp's point 4 (the large program problem with line numbers used as labels for GOSUBs and GOTOs) has, I understand, been licked in some extant BASIC interpreters. In any event, it is clear that that problem can be licked, as well as his points 1 and 2. Now that Mr. Tripp has brought the matter to my attention, it is clear that a good BASIC should support cursor commands such as CURSOR (R,C) to place the cursor, READ CURSOR TO (R,C), and even READ CURSOR LAST TO (R,C). The meaning of the first two statements is (I hope) evident, and the last means 'where was the cursor when the last CR/LF was input?'. All of these can be readily implemented.

This brings us to Mr. Tripp's sixth and final point — the slowness of the interpretation process. All of us know

(presumably) about the use of BASIC compilers to fix this problem and also about the inconvenience of the compilation process. However, there are two ways to cure the problem, which do not involve a separate and distinct compilation. The obvious one is to use a newer, faster processor chip than the 6502 or 6809 with which MICRO readers are familiar.

The second method is to write a BASIC in which the stored program is essentially a compiled BASIC but where tables of variable names, tables of labels and such, are used along with an interpreter during the editing phase only, which makes the operator believe that the BASIC is fully interactive.

Even now, in the industry-standard Microsoft BASIC, a keyword such as GOSUB is not stored as ASCII 'G, O, S, U, B'. Instead, those ASCII characters are replaced with a single byte. Then, when listing the program, the computer makes the operator believe that the program does indeed store the GOSUB command as five ASCII characters. My suggestion is that we (considerably) extend this use of the computer to obscure from the operator the exact form of the stored program while persuading the operator during program input and editing that the stored form is conventional.

All of the complaints raised by Mr. Tripp are valid in some BASICs. Some of those complaints have already been fixed and all of them can be fixed. What we need is a properly written BASIC.

Hal W. Hardenbergh  
Digital Acoustics, Inc.  
1415 E. McFadden, Suite F  
Santa Ana, CA 92705

## Updates and Microbes

### MICRO Calc Mistake

Listing 1 in MICRO Calc (58:47) by Loren Wright contained several errors. [CH] indicates the HOME key. The following lines contained errors or omissions. Note that line 115 is a new line.

## Updates & Microbes

(continued)

```
20 CR#:=CHR#(13):DL#:=
CHR#(20):RB#=" [RVS]
 [OFF]" :BL#=" [20
 SPACES]" :DI#="
 [OFF][CL]"
110 S#:=S#(LL):IF RIGHT
#(S#,1)="? " THEN
PRINT "[RVS]" BL#CR#
 "[CU]" :
115 PRINTS#DI# :
180 IFT#="+" THEN S#(LL)
=S# : GOSUB 5000 : LL=
1 : GOTO 110
2010 IFT#="@ " OR T#:=CR#
OR T#=" [CD]" OR T#="
 [CU]" OR T#="+" OR T#
=DL# OR T#=" [CLR]"
THEN RETURN
8510 PRINT "[CLR]" : FOR
I1=1 TO NL : S#:=S#(I1)
8520 PRINT "[YEL][CD]"
S# "[RVS]" LEFT#(BL#
,20-LEN(S#)) : NEXT :
PRINT "[CH][CD]" :
RETURN READY.
```

### Corrections for Apple Micro Calc

61 THEN  
65 "SS" instead of "BB"  
1000 (Include) POKE 216,0

### Model Rocket Line Change

In listing 1 of "Model Rocket Simulation in BASIC" by David Eagle (56:31), substitute ↑ for the ± in line 120.

### Missing Line

I caught an omission in the program BANK from "Discrete Event Simulation in Pascal" in the January issue (56:21). Add the following line: newtime := round(rnexp(1,uariv)) + time; just before the line "schedule ('d',newtime);" in 'service'.

Jeff LaBarre  
Santa Monica, CA

### Review Correction

The review of WP 6502 Version 1.3a from Dwo Quong Fok Lok Sow (57:99) needs a slight revision. Replace the last sentence in the documentation section with: "The disk is supplied with a number of text files already in place, complete with errors to be corrected with the editing features of WP 6502."

Earl Morris  
Midland, MI

**MICRO**

**At Last! Two new ways to expand the usefulness of your Rockwell AIM or Cubit CPU computer are available for immediate, off-the-shelf delivery.**

**To discover how two new, state-of-the-art circuit cards from Design Dynamics can expand the use you get from your AIM or Cubit computer by providing bus compatible Analog to Digital Interface and Full Color Graphics, please read on.**

Until now, if you needed a complete Analog to Digital Interface or Full Color Graphics display for your AIM or Cubit computer, you had to design and build it yourself.

But today, Design Dynamics fills each need on 4½" x 6½" cards. Just look at the features packed into each card:

#### A total control interface

The AIM/Cubit-compatible interface has been designed to provide you with a flexible, total control interface which includes A to D functions, D to A functions, a clock with user ports section and a User Prototyping Area. Circuit Card with all functions, \$1,100.

#### Boards with selected functions

Analog to digital input is handled on 16 channels with 12 bit resolution. Maximum conversion time is 35 μsec. per channel. Card with only A to D function, \$375.

Digital to analog output provides control of 0 to 10 Volts. 8 μsec. conversion is provided by double-buffered, 4 channel, 12 bit D/A converters. Card with only D to A function, \$675.

A 24-hour time of day clock, with independent crystal time-base, includes an alarm mode for scheduling events. Two 16 bit timers, each with 16 bit prescaler and start/stop control can count multiple source pulses.

And, a User Prototyping Area provides power, ground bus and grid area for custom signal conditioning. Clock with Prototyping Area Card, \$275.

Start-up software for each circuit card is provided.

#### Full Color Graphics

Now you can expand your system display from limited alpha-numerics to a full color CRT display which includes two graphic modes, multicolor mode and text mode, viewed on your own color CRT.

Design Dynamics Full Color Graphics uses no system RAM, and includes its own 16K dynamic RAM memory. It provides 35 planes of vertically stacked display, 32 sprites in front of graphic plane and internal anti-collision management.

Graphics I provides pattern graphics in 15 colors, 256 x 192 pixels; while Graphics II offers more complex colors and patterns. The Multicolor mode displays in positions of 64 x 48, with four colors per 8 x 8 pattern. The Text mode pattern plane is broken into 40 x 24 positions for text-only display. Full Color Graphics Card, \$175.

Startup software included assists the user in becoming familiar with the extensive capacities of this board.

#### Full documentation included

A Data Pack which includes full documentation for each board makes it simple to put the A to D Interface and Full-Color Graphics to immediate use. Or, if you need to be sure these boards will fit your applications, you may order the Data Pack separately for only \$15 per card.

#### Motherboard available

A fully buffered Motherboard for system expansion of eight cards allows convenient placement of boards for prototyping. Expansion Motherboard is \$175.

#### Save time, money; call today

Get these AIM and CUBIT function-expanding cards *right now*, or call Jack Schnabel for complete information.

## DESIGN DYNAMICS

1830 Soscol Avenue • Napa, California 94559 • (707) 257-6000

Rockwell AIM is a trademark of Rockwell, International • Cubit CPU is a trademark of Cubit, Incorporated

Circle No. 8

## FOX 20:™

The magazine for \*VIC-20 users  
\*1982

FOX 20 will provide you, each month, with 5 or more ready-to-run programs on cassette-exciting, imaginative, game, educational, and utility programs for most VIC memory configurations. In addition, you will receive Foxtales, an informative Video Newsletter, on Side 2. Novice and pro alike, FOX 20 is the magazine for you. Be a sly little fox for only \$53 a year - \$6.50 single issue.

### FOX 20 is a division of:

Foxtire Systems, Inc.  
3811 Newton  
Pasadena, Texas 77503

To order: Send check (U.S. Funds), add 5% Sales Tax for Texas residents, Canada and Overseas \$63, orders pre-paid. Dealer and author inquiries invited.

## FOX 20:™

The magazine for \*VIC-20 users  
P. O. BOX 507  
Deer Park, Texas 77536  
(713) 473-6723



\*VIC-20 is a trademark of  
Commodore Business Machines

Circle No. 9

# MICRO™

## Editorial

### The New Wave

When we decided to run a feature on the "new wave" of computers almost a year ago, we knew several new systems with different types of configurations would be entering the market in 1983. We believe these computers are an important trend and — because of the low prices — will help draw more people into the world of microcomputers. As discussed in last month's editorial our latest section, The Learning Center, will offer new users programming techniques and applications for these systems.

But we want readers who have been with us over the past few years to know that we are going to continue to support them. Apple and PET owners will still find high-level information and programs. And we'll also offer *advanced* material for VIC-20, TRS-80 Color Computer, Commodore 64 and Atari users, in addition to The Learning Center.

There is no doubt that the nature of the microcomputer world is changing — it's no longer only for the highly technical computerists using complicated and expensive systems. Technology has allowed manufacturers to produce sophisticated yet easy-to-use computers at an inexpensive price. No longer is there the huge gap between strictly game machines and intimidating computers. There are many varieties in the middle. Micro will keep you up to date on future "new wave" systems and how to use them.

## COMPU SENSE!

QUICK BROWN FOX **\$60.95**  
The #1 word processor!

GENERAL LEDGER **\$19.95**  
(VIC-20)

CHECK MINDER  
VIC-20 **\$19.95** C-64 **\$24.95**

HOME INVENTORY **\$19.95**  
(VIC-20)

CENTIPOD **\$27.95**  
Like Centiped, only better!

FROGEE **\$27.95**  
The exciting arcade game of Frogger.

MOTOR MOUSE **\$29.95**  
What a cheese'ee game!

CRIBBAGE  
VIC-20 **\$14.95** C-64 **\$17.95**  
This is the game of Cribbage.

STAR TREK  
VIC-20 **\$12.95** C-64 **\$17.95**  
Excellent adventure game!

MASTER MIND  
VIC-20 **\$12.95** C-64 **\$19.95**  
Makes you think.

ROACH MOTEL **\$9.95**  
Kill the bugs!

YAHTZEE 1.1 **\$12.95**

YAHTZEE 2.1 **\$14.95**

TO ORDER:  
P. O. BOX 18765  
WICHITA, KS 67218  
(316) 263-1095



Personal checks accepted  
(Allow 3 weeks) or  
C.O.D. (Add \$2.00)  
Handling charges \$2.00

VIC-20® is a registered trademark of Commodore

Circle No. 10

### MICRO Moves North!

We're still tripping over boxes and packing foam, but everyone agrees that our move to southern New Hampshire was a good idea. Our brand new offices among the pine trees will provide an inspiring setting to continue to mold MICRO into an exciting magazine.

Of course, as with any move, we (and our readers, advertisers, and authors) suffered thorough quite a bit of confusion. For instance we were in the new building for three days before the phones actually worked. So if you tried to call our old number you were connected with the few souls left in Chelmsford who had no information except our new number — which wasn't working yet! We apologize for any inconveniences.

A big reason for the trek north is that over half the staff lives in southern New Hampshire. Commuting time has been cut considerably, which gives us more time to devote to the magazine. So, as soon as the phone lines are connected and the last box gets unpacked, we'll all be smiling and back to work as usual.

Our new address is: 10 Northern Blvd., Northwood Executive Park

P.O. Box 6502

Amherst, NH 03031

Our new phone number is: (603) 889-4330

Marjorie Morse

MICRO™

# Lyc0 Computer Marketing & Consultants

TO ORDER

CALL US

TOLL FREE 800-233-8760

In PA 1-717-398-4079

**FREE**

DUST COVER  
with Purchase of

ATARI 800 48K .... \$489.00

ATARI 400 64K .... \$349.00

810 DISK DRIVE.....\$419.00

ATARI 1200 64K RAM... \$CALL \$



A Warner Communications Company

## ATARI HARDWARE

810 DISK DRIVE.....\$419.00  
410 RECORDER .....\$75.00  
1010 RECORDER.....\$75.00  
850 INTERFACE.....\$164.00

### PACKAGES

CX482 EDUCATOR .....\$119.00  
CX 483 PROGRAMMER.....\$54.00  
CX488 COMMUNICATOR .....\$219.00  
CX419 BOOKEEPER .....\$189.00  
KX7104 ENTERTAINER .....\$69.00

### NEW RELEASES

400 KEYBOARD.....\$99.00  
MINER 2049er.....\$32.75  
FROGGER.....\$25.75  
PREPPIE.....\$19.75  
SEA DRAGON.....\$24.75  
STRATOS.....\$24.75  
DISKY.....\$39.95  
MONKEY WRENCH 2.....\$52.75

## MONITORS

NEC JB1260.....\$125.00  
NEC JB1201.....\$155.00  
NEC TC1201.....\$315.00  
AMDEK 300G.....\$159.00  
AMDEK COLOR I.....\$329.00

## MODEMS

ANCHOR MARK I.....\$79.00  
ANCHOR MARK II.....\$79.00  
HAYES SMART.....\$239.00  
HAYES MICRO II.....\$309.00  
CAT.....\$144.00  
J-CAT.....\$CALL \$

## PERCOM DISK DRIVES

SINGLE DRIVE AT88.....\$389.00  
ADD ON.....\$289.00  
SINGLE DRIVE 40S1.....\$529.00  
ADD ON.....\$329.00  
DUAL DRIVE 40S2.....\$845.00  
DUAL HEAD SINGLE DRIVE 44S1 ...\$649.00  
DUAL HEAD DUAL DRIVE 44S2....\$789.00

# SAVE on these in-stock PRINTERS

PROWRITER.....\$375.00

NEC 8023A.....\$439.00

SMITH CORONA TP1 ...\$569.00

STARWRITER.....\$1475.00  
PRINTMASTER.....\$1675.00

## PRINTER CABLES

for Atari

CITOH.....\$35.00  
EPSON.....\$35.00  
NEC.....\$35.00  
OKIDATA.....\$35.00  
SMITH CORONA.....\$35.00

OKIDATA 82A.....\$419.00  
OKIDATA 83A.....\$639.00  
OKIDATA 84.....\$1029.00  
OKIDATA TRACTOR.....\$63.00

## DISKETTES : In Stock

BASF.....\$19.00  
ELEPHANT.....\$21.00  
MAXELL MDI.....\$34.00  
MAXELL MDII.....\$44.00

## BUSINESS SOFTWARE

VISICALC.....\$159.75  
LETTER PERFECT.....\$115.75  
LETTER PERFECT ... ROM...\$159.75  
DATA PERFECT.....\$75.75  
TEXT WIZZARD.....\$79.75  
SPELL WIZZARD.....\$64.75  
FILE MANAGER 800+.....\$69.75  
ATARI WORD PRO.....\$109.75



POLICY  
DURING APRIL



In-Stock items shipped within 24 hours of order. Personal checks require four weeks clearance before shipping. No deposit for COD orders. PA residents add sales tax. All products subject to availability and price change. Advertised prices show 4% discount offered for cash. Add 4% for Mastercard and Visa.

Circle No. 11

TO ORDER

CALL TOLL FREE

800-233-8760

In PA 1-717-398-4079  
or send order to

Lyc0 Computer  
P.O. Box 5088

Jersey Shore, PA 17740

NAME BRAND

# SUPER SALE

Bulk Diskettes\* with envelopes

\*Now Get High Quality at a Low Price Manufactured by a Major Disc Company For MDS Without Their Name on Diskettes \*Minimum order 20 diskettes with Tyvek envelope and storage shipping box \*Quantity Discounts - 100 deduct 3%, 1000 deduct 5%, 10,000 deduct 10% - 100+ Certified 1 Year Warranty

## 5 1/4" Soft Sectors

SINGLE SIDE SINGLE DENSITY W/HUB RING	<b>\$1.69*</b>
SINGLE SIDE DOUBLE DENSITY W/HUB RING	<b>\$1.99*</b>
DOUBLE SIDE DOUBLE DENSITY W/HUB RING	<b>\$2.79*</b>

## 8" Soft or 32 Sectors

SINGLE SIDE SINGLE DENSITY	<b>\$1.79*</b>
SINGLE SIDE DOUBLE DENSITY	<b>\$2.29*</b>
DOUBLE SIDE DOUBLE DENSITY	<b>\$3.09*</b>

## PRINTERS

All EPSONS available	..... \$call
GEMINI 10 by Star Micronics	\$359.00
GEMINI 15 by Star Micronics	\$549.00
Okidata Microline 80	..... \$call
Okidata Microline 82	\$469.00
Okidata Microline 83A	..... \$call
Okidata Microline 84	..... \$call

## MICROBUFFER

MBP-16K Parallel	..... \$149.00
MICROBUFFER IN-LINE For Most Printers	
32K Parallel	..... \$289.00
64K Parallel	..... \$339.00
32K Serial	..... \$289.00
64K Serial	..... \$339.00
64K Memory	
Expansion Modules	..... \$169.00

## TANDON DISK DRIVE ENCLOSURES

Complete with Chassis & Power Supply: Fully assembled silver or beige chassis with external card edge connector for easy cable installation for 5 1/4" drives. With MDS 120 days warranty ..... \$59.00



## BARE DRIVES

TM100 1 40 Trk	..... \$199.00
TM100 2 40/40 Trk	..... \$269.00
TM100 4 80-80 Trk	..... \$339.00
SIEMENS FDD100 8 SS/DD 8 in	..... \$279.00
TM50 SS DD 40 Trk Thinline	..... \$199.00
TM84B 1 SS/DD 8" 77 Trk Thinline	..... \$369.00
TM84B 2 DD/DD 8" 77 Trk Thinline	..... \$479.00

Add \$59.00 For Complete 5 1/4" Drive System



## MCB 1000 High Performance Business System

- Includes FREE MicroPro Software: • WordStar • SpellStar • MailMerge • CalcStar • And More • Z-80A C.P.U. • 64KB RAM • 328KB mini floppy disk drive • CP/M operating system • 12" non-glare green phosphor video display screen • Centronics parallel printer port • RS232C serial port • Additional disk drives up to 2.3MB



**\$1595**  
SAVE \$2000\*

Free shipping on all prepaid orders over \$100.00 in U.S.A.

(\* If purchased separately)

CASH ORDERS ONLY

# MDS MICRO DATA SUPPLIES

22295 EUCLID AVE.  
EUCLID, OHIO 44117

Call (216) 481-1600

WE ACCEPT  
• Visa  
• MasterCard  
• Checks  
• Money Order  
• C O D

ALL PRICES ARE FOR MAIL ORDER ONLY Prices, Specifications and Offerings subject to change without notice

ADD \$3.00 FOR SHIPPING & HANDLING \$6.00 Extra for C O D Orders Ohio Residents add 6.5% Sales Tax

DEALER INQUIRIES WELCOME

Circle No. 12

# MICRO™

## PET Vet

Loren Wright

One convenience offered by Commodore computers is the load-and-run function of the shifted RUN/STOP key. With BASIC 4 PETs and CBMs, pressing the key loads the first program on drive 0 of the disk and immediately RUNs it. With the VIC, Commodore 64, and pre-BASIC 4 PETs, pressing the key causes the next program on tape to LOAD and immediately RUN. Doing this from within a program is a different story, though.

There are many applications for LOAD-and-RUN programming, and even more ways to accomplish it. You can load one program from another without destroying the variables defined in the first. This is a technique described by Jim Strasma in Part 1 of his "It's All Relative" series [MICRO 55:37, December '82] under the topic of chaining. Strasma's application was a mailing list program that used one start-up module to define a number of constants, with some based on the current equipment configuration. This way he could avoid redefining these in every new module. The technique also allowed him to pass parameters from one module to another. For more details see Strasma's article.

It is also possible to perform this kind of chaining without changing the values of pointers if you make sure the first program is always longer than the second. If this isn't the case, then add some extra REM statements at the end of the first program. This technique is essential if you have a program that is too long to fit into memory at once. Just find a convenient place to split it, make the first part longer than the first, and include an appropriate LOAD statement for the second part. Variables do not have to be redefined and are passed intact to the second program.

We now have techniques for chaining programs without destroying variables. However, there are situations when neither of these techniques will do the job. One is when you want to load a machine-language program at the top of memory, followed by a BASIC driver. Another is when you need to do a NEW before running the second program. In both cases we need the pointers set to their default values, but the programmed LOAD leaves them as they were for the original program. Also, since a NEW causes the program in memory to disappear, you can't very well LOAD a new program if the LOAD instruction no longer exists! (Continued on page 14)

### PET Vet Listing

```
10 Q$=CHR$(34): NC=158: KB=623:
   DN$=",8": PO$="000000"
20 PRINT "Q": FOR I=1 TO 3: READ NA$(I)
   ): PRINT NA$(I) "Q": NEXT
30 INPUT "Q INPUT PROGRAM #": N
40 PRINT "Q NEW"
50 PRINT "Q LOAD" Q$ NA$(N) Q$ DN$
60 PRINT PO$ "RUN"
70 POKE NC,4: POKE KB,19: FOR I=1
   TO 3: POKE KB+I,13: NEXT
1000 DATA PROGRAM 1,PROGRAM 2,
   PROGRAM 3
```

# SJB DISTRIBUTORS. THE MOST COMPETITIVE PRICES ON COMMODORE.



## NEW COMMODORE PRODUCTS

CBM 64	Call
CBM B500	\$ 695
CBM B700	2990
CBM 1520 Plotter	259
CBM 1701 Color Monitor	279
B Series Software	Call

## SOFTWARE FOR CBM 64

Word Processing (WordPro 3+)	\$ 69
Word-Pac (tape)	60
The Assistant Series	
Writer's Assistant (easy and flexible)	99
File Assistant (database with merge)	99
Spreadsheet Assistant	99
Pers. Finance Assist. (great reports)	45
Busicalc (Spreadsheet)	55
Coco II (build your own games easily)	45
Home Accounting Package	39
General Ledger, A/R, A/P (with check writing)	ea. 139
CBM EasyFinance	50
CBM EasyScript	80
CBM EasyFile	80
Data Manager	70
Stock (investment analysis)	80
Pet Emulator (emulates 4.0 basic)	30
Sprite-Magic (use joystick to design sprites)	19
Assembler Package (cassette or disk, compiled, includes editor, loader, disassembler)	39
Spacebelt	20
Retrobball	34

## INTERFACES & ACCESSORIES

80 Column Expander	\$159
VIC 1600 Modem	95
VIC 1650 (auto answer, auto dial)	150
VIC 1525 Graphic Printer	329
VIC 1530 Datasette Recorder	65
VIC 1541 Disk Drive	329
VIC Switch (connect 8 64's or Vics to printer, dd)	149
IEEE Interface (64)	85
PET-IEEE cable	33
IEEE-IEEE cable (2m)	43
Parallel Interface (Epson, Okidata, IDS, NEC)	80
RS-232 Printer Interface (Okidata, Diablo, etc.)	60
Programmers Reference Guide	18
Verbatim Diskettes (10 per box)	26
Vicree (Programmers Utility)	75

## VIC PRODUCTS & ACCESSORIES

8K RAM Memory Expansion Cartridge	\$ 40
16K RAM	70
24K RAM	105

VIC IEEE Interface	75
VIC 3 Slot Expander	27
VIC 6 Slot Expander	70
RS-232 Printer Interface	65
Cassette Interface	27
Home Finance Package (6 tapes)	47
Gorf (64 also)	30
Omega Race	30
Arcade Joystick - Heavy duty w/2 firing buttons! Great for the VIC or 64	25

## MONITORS - GREAT RESOLUTION (64 OR VIC)

Amdek Color I	\$ 299
Amdek II or III	call
Panasonic CT160	279
Comrex 6500 - 13" Color	299
Transtar 20 (High Resolution Green Phosphor)	129
Video/Audio Cable	15

## PRINTERS - LETTER QUALITY

CBM 8300, 40 cps	\$1450
Diablo 620, 25 cps	949
ComRiter, 17 cps	819
Transtar 130, 16 cps (auto load, wp features!)	769
NEC 7700 series	2350
NEC 3500 series	1600

## PRINTERS - DOT MATRIX

CBM 8023, 150 cps/graphics	589
Epson FX Printer, 160 cps	529
Epson MX-80 w/Grafix	349
CBM Graphics for Epson	65
Okidata 82A, 120 cps (serial and parallel)	429
NEC 8023A (parallel)	439
Okidata 92	559
Star Gemini, 10	360
Star Gemini, 15	499

## COMMODORE BUSINESS SERIES

SuperPet (5 languages, 2 processors)	\$1409
CBM 8032 Computer, 80 Column	1029
CBM Memory Expansion, 64K	359
CBM 8050, 1 mg. Dual Drive	1259
CBM 8250, 2 mg. Dual Drive	1500
CBM D9060, 5 mg. Hard Disk	2240
CBM D9090, 7.5 mg. Hard Disk	2600
CBM 2031, 170K Single Drive (New)	489
DC Hayes Smart Modem	220

## BUSINESS SOFTWARE

WordPro 4+ or 5+	\$ 309
Administrator	489
VisiCalc (expanded)	199
The Manager (database)	199
BPI A/R, G/L, Job Cost, Inventory, Payroll	ea. 325

## MasterCard, Visa, Money Order, Bank Check

COD (add \$5) accepted.  
Add 3% surcharge for credit cards.  
In stock items shipped within 48 hours,  
F.O.B. Dallas, Texas  
All products shipped with manufacturer's  
warranty.

Prices are subject to change without notice.

## TO ORDER CALL TOLL FREE

**800-527-4893**  
**800-442-1048**  
(Within Texas)

Business Hours  
Mon.- Fri. 8 to 6, Sat. 10-2

Write for free catalog.

## GAME OF THE MONTH

Adventu-Writer (make your  
own adventure game) ..... 39



## SJB DISTRIBUTORS INC.

10520 Plano Road, Suite 206  
Dallas, Texas 75238  
**(214) 343-1328**

Circle No. 13

# COMMANDER

THE MONTHLY JOURNAL FOR  
COMMODORE COMPUTER USERS

SUPER PET

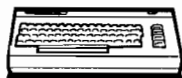

VIC-20

PET/CBM



## GET YOUR MONEY'S WORTH

You've probably made a sizeable investment in your computer equipment. **COMMANDER** can help you make the most of it.

Each issue brings you the *no-nonsense* advice you need to stay on the leading edge of this constantly changing field. **COMMANDER** will be your reference to the world of computers... with the best, most comprehensive coverage you can get!!



Subscribe now and take advantage of our limited offer of \$4 off the one year subscription.

1 YR. U.S. \$22  2 YR. U.S. \$40  3 YR. U.S. \$58  
(Prices do not include \$4 Discount) Prices in U.S. Funds  
Washington residents please add 7.8% sales tax

—Subscription Orders Only—  
Toll Free Number: 1-800-426-1830  
(except WA, HI, AK)

**COMMANDER**  
P.O. BOX 98827  
TACOMA, WASHINGTON 98498  
(206) 565-6816

Circle No. 14

# MICROSPEC

## Quit Playing Games . . . Disk Based Software to Make Your Computer Get Down to Business

**Disk Data Manager**—Create and manage your own data base. Allows you to create, add, change, delete, search, sort, print, etc. Up to 1200 records on a single disk.  
VIC 20 . . . 59.95    CBM 64 . . . 89.95

**Payroll System**—Full featured, complete payroll system. Even prints checks.  
VIC 20 . . . 89.95    CBM 64 . . . 99.95

**Mailing List**—Up to 1200 records on a single disk. Presorts by Zip Code. Prints on stock up to four labels wide.  
VIC 20 . . . 44.95    CBM 64 . . . 54.95

**Inventory Package**—Maintains quantity on hand, cost, sales price, reorder point, etc. Generates suggested reorder, sales report, and sales analysis.  
VIC 20 . . . 89.95    CBM 64 . . . 99.95

**General Ledger**—Up to 75 accounts! Generates Balance Sheet, Income Statement, Update Report, etc.  
VIC 20 . . . 89.95    CBM 64 . . . 99.95

**Checkbook Manager**—Up to 25 expense categories. Tracks all outstanding checks until they are paid.  
VIC 20 . . . 49.95    CBM 64 . . . 49.95

### CONTACT US FOR ALL YOUR DISK BASED SOFTWARE NEEDS

Call for specifics on Hardware Configurations.  
Send Self-Addressed Stamped Envelope for  
Catalogue of Games and other Applications  
DEALER INQUIRIES WELCOME



P.O. Box 863085  
Plano, Texas 75086  
(214) 867-1333



VISA and MASTERCARD Accepted

Circle No. 15

## PET VET (continued)

Having just finished preparing MICRO's new book "Mastering Your VIC-20" for publication, I wanted to be able to demonstrate the programs at the West Coast Computer Faire. The book comes with a cassette, but obviously that is not the appropriate medium for a demonstration. I needed a menu program that would display a list of the programs on the screen and automatically LOAD and RUN any program selected. I tried making my menu program longer than the longest program by adding REMs at the end, but that didn't leave enough room to store the variables created by other, shorter programs. Also, several programs involved lowering the top-of-memory pointer to protect RAM-defined character sets. When a longer program is loaded after one of these, there isn't enough memory available. Obviously (since nothing is impossible), a different technique was required. I read about this technique in the early PET literature, but rather than digging through back issues, I decided to rediscover it myself.

### Programming the Keyboard Buffer

This technique has a number of applications besides automatic loading, including having a program add lines to itself or write a whole new program! One commonly used variation is to convert machine language into BASIC DATA statements.

The addresses involved are different for the different Commodore machines, so consult the table for the Addresses for your machine. Below is a demonstration program for loading one of three programs. (It is up to you to make sure there actually are programs by those names on the disk!)

### The Table

Function	Variable	BASIC 1	BASIC 2/4	VIC/C64
No. of chars. in keyboard buffer	NC	525	158	198
Start of keyboard buffer	KB	527	623	631

### Program Description

What the program accomplishes is very simple. First a NEW statement is executed, then the LOAD, and finally a RUN — all as if they were typed in the direct mode. The keyboard buffer holds up to ten keys in sequence, and the PET processes them one at a time in the order they entered the queue. The program puts the commands on the screen in the proper positions. Line 70 puts a 4 in address NC, telling the PET that there are four unprocessed keys left in the buffer. Then four characters, a home and three returns, are put into the first through fourth positions in the buffer. The program is done, but the PET must process those four characters. The effect is as if you typed the commands yourself and then pressed the RETURN key.

Change the values of NC and KB according to your Commodore computer. If you are working with cassette, you are limited to the next program on the tape. To experiment with the automatic load you will also have to change DN\$ to "1" or " " and add three more cursor-down's to PO\$.

MICRO™





# Micro The Computer Book Club®

"The ONLY Book Club for micro users"

Play games . . . develop new programming skills . . .  
organize your finances . . . earn extra income . . .  
even build your own microcomputer . . .

## HAVE IT ALL FOR ONLY \$2.95

Select any 5 books, (values to \$103.75)  
for only \$2.95 when you join  
The Computer Book Club®!



1391  
List \$17.95

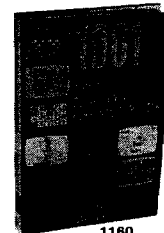

1160  
List \$13.95



1455  
List \$15.95



1350  
List \$15.95

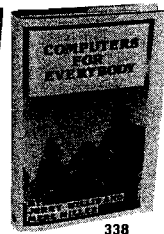

338  
List \$14.95



1228  
List \$14.95



1407  
List \$17.95



1513  
List \$19.95

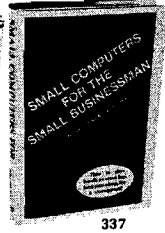

337  
List \$19.95

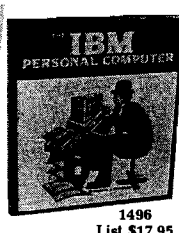

1496  
List \$17.95



1276  
List \$15.95

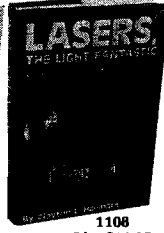

1108  
List \$14.95

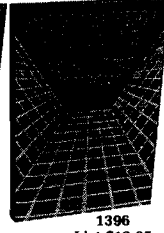

1396  
List \$13.95



1330  
List \$16.95



1485  
List \$21.95

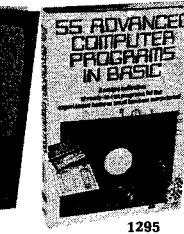

1295  
List \$16.95



1277  
List \$19.95

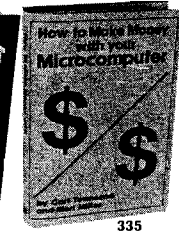

335  
List \$14.95

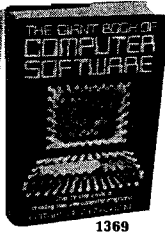

1369  
List \$21.95



1062  
List \$13.95



1183  
List \$14.95

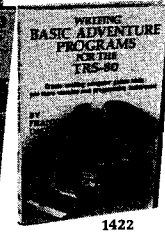

1422  
List \$14.95



1521  
List \$17.95

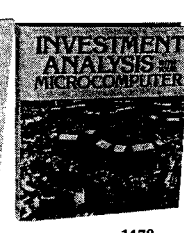

1479  
List \$19.95

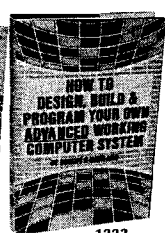

1332  
List \$16.95

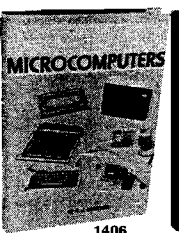

1406  
List \$17.95

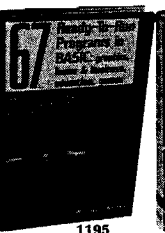

1195  
List \$13.95



1205  
List \$16.95

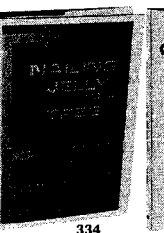

334  
List \$16.95

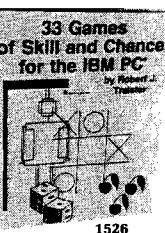

1526  
List \$18.95

## 7 very good reasons to try Micro The Computer Book Club®

Blue Ridge Summit, PA 17214

- **Reduced Member Prices.** Save 20% to 75% on books sure to increase your computer know-how
- **Satisfaction Guaranteed.** All books returnable within 10 days without obligation
- **Club News Bulletins.** All about current selections—mains, alternates, extras—plus bonus offers. Comes 13 times a year with dozens of up-to-the-minute titles you can pick from
- **"Automatic Order."** Do nothing, and the Main selection will be shipped automatically! But . . . if you want an Alternate Selection—or no books at all—we'll follow the instructions you give on the reply form provided with every News Bulletin
- **Continuing Benefits.** Get a Dividend Certificate with every book purchased after fulfilling membership obligation, and qualify for discounts on many other volumes
- **Extra Bonuses.** Take advantage of added-value promotions, plus special discounts; on software, games, and more
- **Exceptional Quality.** All books are first-rate publisher's editions, filled with useful, up-to-the-minute information



## Micro The Computer Book Club®

Blue Ridge Summit, PA 17214

Please accept my membership in The Computer Book Club® and send the 5 volumes circled below, billing me \$2.95 plus shipping and handling charges. If not satisfied, I may return the books within ten days without obligation and have my membership cancelled. I agree to purchase 4 or more books at reduced Club prices (plus shipping/handling) during the next 12 months, and may resign any time thereafter.

334 335 337 338 1062 1108 1160 1183  
1195 1205 1228 1276 1277 1295 1330  
1332 1350 1369 1391 1396 1406 1407 1422  
1455 1479 1485 1496 1513 1521 1526

Name \_\_\_\_\_ Phone \_\_\_\_\_

Address \_\_\_\_\_

City \_\_\_\_\_

State \_\_\_\_\_ Zip \_\_\_\_\_

Valid for new members only. (Orders outside U.S. or Canada must be prepaid in International Money Orders in U.S. dollars. Canada must remit in U.S. dollars.) This order subject to acceptance by The Computer Book Club®. MCRO-583

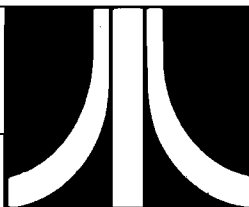

Paul S. Swanson

This month's column is based largely on a letter I received from Jose H. Nieto, a MICRO reader in Venezuela. His letter outlined a few questions that are commonly asked in reference to specific applications. His application included drawing geometric shapes.

Mr. Nieto's first question was about monitors. When drawing shapes in mode 8, you will get color artifacts on any compatible monitor or television because of the mechanics of the signal, although some monitors will reduce the artifacts a bit. However, using the computer for plotting single points to define geometric shapes does not really require color in mode 8. This mode actually is a one-color mode, allowing two luminances. I would prefer to do such work with a good black and white or green phosphor monitor. The image is much clearer than that obtained by either a television or a color monitor.

The Atari 800 computer can be connected to almost any raster scan monitor that uses the same sync signals a television uses. The Atari 400 cannot be connected to a monitor; its only video output is combined with its only audio output and modulated for television use.

The second question in the letter deals with connecting an Atari 800 computer to a stereo amplifier. First, the sound output from the Atari is monaural. You can still use a stereo amplifier, but you will not get stereo sound. The jack on the side of the Atari 800 has connections for the monitor and the sound channel. This jack has five pins on it. The ground pin is the lowest pin on the jack (pin 2). This should be connected to the ground wire of anything you connect to this jack. The "live" connection for sound is pin 3, which is the top pin on the left side as you look at the jack. If you connect both audio input lines to this pin (the "live" from each channel) your stereo amplifier should work just fine. The proper place in your amplifier to connect the Atari output is the auxiliary input or the phonograph input (if there is no auxiliary input).

For color monitors, pin 4 is the proper place to connect the live video wire. Black and white does not require

the color information and I have had better results connecting those monitors to pin 1, which is composite luminance. Pin 4 is composite video, which will carry the color burst required for color pictures, but not required for black and white.

Another question in Mr. Nieto's letter refers to the use of a PRINT #6 command with a mode 0 screen. This will normally leave inverse video spaces at the end of each line. If you want to access a mode 0 screen with PRINT #6, don't use a GRAPHICS 0 statement. Instead, declare the mode with the following statement:

```
OPEN #6,0,0,"E:"
```

The screen is opened with a GRAPHICS statement as the screen handler (device S:). Using the screen editor, device E:, will eliminate the white squares. The white squares you get when you use GRAPHICS statements with PRINT#6 is actually the cursor, unreversed after it is moved. Use the device E: and you won't have to worry about it.

Since the white squares left behind are unreversed cursors, there is another simple solution to this. Turn off the cursor right after you declare GRAPHICS 0. This can be done by a POKE 752,1.

When you use GRAPHICS 0 and the POKE 752,1, you can use COLOR, PLOT, and DRAWTO with a mode 0 screen. Try, for example, the following short program:

```
10 GRAPHICS 0
20 POKE 752,1
30 PRINT
40 COLOR ASC("A")
50 PLOT 0,0
60 DRAWTO 10,10
```

Lines 10 and 20 open the screen and shut off the cursor. Line 30 eliminates the single white square that would be left if the PLOT were to be executed without it. The COLOR in mode zero is the character to print. The PLOT and DRAWTO will set a diagonal line comprised of A's on the screen. Eliminate line 30 to see the cursor that it eliminates. Change the COLOR state-

ment for other characters. The control characters will print as characters in this method, so you can declare COLOR 28 in line 40 and get a line of up arrows. Even the ESC character works (COLOR 27). Only RETURN (COLOR 155) gives unusual results.

One last question concerns the graphics available on printers. There is no redefinable character set on the Atari 820 printer and I know of no graphics available on it either. The printer I use is an Epson MX-80 with Graftrax Plus. The character set on that printer is also not programmable, but you can address all of the dots on each line individually in its graphics modes. It is rather simple to write a screen dump program for the Epson, if you dump the screen sideways. If you have an Epson with any Graftrax option, read the graphics section of your Epson manual and you will see how this can be done.

Both of the 800 series Atari 40-column printers also have graphics capabilities. If you do not need the 80-column width, the suggested \$299.00 retail price of these printers may be worth considering.

### New Hardware

In other news, Atari has a few products to add to their computer line. In addition to the well-publicized 1200, Atari has a new Program Recorder, model number 1010, that is scheduled for first quarter (it should be available by the time you read this). The 1010 is like the 410 except it has a case design more similar to the new look of the Atari 1200. Also reported is that this new recorder has an improved mechanism. It will be in the same price range as the Atari 410.

In the second quarter, two new printers are scheduled. The Atari 1020 is listed as a 40-column color printer. It actually functions like a drum plotter with colored pens. It uses the 40-column sized paper and can be addressed as a printer. The characters printed to it are plotted in normal, compressed, or expanded mode, as controlled by the program. The suggested retail price for the 1020 is \$299.00.

The Atari 1025 is a new 80-column printer that does not require the 850 interface. It reportedly does not have graphics capabilities. Suggested retail price for the 1025 is \$549.00.

Write to Paul at 97 Jackson St.,  
Cambridge, MA 02140.

# MICRO™

## CoCo Bits



by John Steiner

The winds of change blow surely through the computer industry, and the Color Computer is not to be left behind. A newer, more powerful DOS is rumored to be on the way, though as I write this there is still no official word from Tandy. The release cannot be too far off as there is mention of an Extended Disk BASIC 1.1 ROM in "The Sands Of Egypt," a newly released adventure game from Radio Shack. There is at least one new command added to the ROM. To execute the program from the 1.1 ROM, just enter 'DOS'. The 1.0 version must use the RUN file command. Tandy will let us know when they are ready.

I noted in a previous column that the color output of my TDP 100 was different from the standard Radio Shack CoCo. This is indeed the case; I have seen the differences in many programs, including the one just mentioned. Computerware says this is a problem on early model TDPs, and they are sending me modification data that will correct the color problem. The new board is now being installed in Radio Shack CoCos, and I am wondering if anyone who has one has noticed a difference from the earlier boards. If you have any information on this, please pass it along.

I am using my TDP and disk system, but with a borrowed disk controller card. The 6809 and controller card failed. The computer has been repaired, and the controller is awaiting a new ROM chip. It should be in any day now. I had been running a tape-based program, and had shut the computer off to reinstall the controller. When I powered up again, the system was down. There is no buffering between the processor and ROM slot, nor is there any between the controller input and ROM. A failure of either unit can easily damage both. As a precaution, be sure the power is off several seconds before reinstalling a card in the slot. Hardware hackers take note: a bi-directional buffer would be relatively easy to build and would allow protection for equipment on the line.

### Modems and Things

I received a letter from Paul Van De Plas of Vancouver, BC. He has a Hayes Stack Smart modem, and a CoCo. He would like to use the auto-dial feature and the built-in Morse Code send/receive feature of the modem, but has been unable to access them using the CoCo. If you have any information on using the Hayes modem with the CoCo, pass your information along.

Though I have been using CoCo as a radioteletype terminal in my ham radio hobby, I have never had a telephone modem. When I needed one, I used an old, acoustic coupler, an originate-only unit that I borrowed from a friend. I never felt that the cost of a modem was worth what use I would get out of it. That changed when I happened across a Mura MM100 direct connect, originate/answer unit. The modem is under \$100 and takes up only a little space on my crowded desk. I placed it on top of my

*(Continued on page 18)*

The  
**MIDNITE**  
SOFTWARE GAZETTE

The  
**PAPER**

A Bi-Monthly Journal of Notes,  
Reviews and Articles  
Five Years of Service to the PET® Community



First  
The Independent U.S. Magazine for  
Users of Commodore Brand Computers

EDITORS: Jim and Ellen Strasma

\$20 US / YEAR

Sample Issue free on request, from:  
635 MAPLE, MT. ZION, IL 62549 USA  
217/864-5320

Circle No. 18

# maxell

## the top of the line

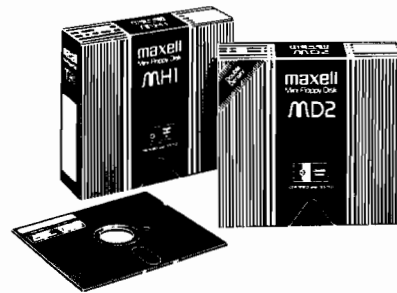

## at the lowest price!

Call our Modem Hotline (anytime) - 619-268-4488  
for exclusive monthly specials. Our free catalog  
contains more than 600 fantastic values.

### ABC Data Products

(formerly ABM)

8868 CLAIREMONT MESA BLVD.  
SAN DIEGO, CALIFORNIA 92123

ORDERS ONLY  
800-854-1555

ITT TELEX  
4992217

INFORMATION  
619-268-3537

## ATTENTION PROGRAMMERS!!

DATASOFT is currently seeking programs and programmers to add to their rapidly growing and expanding operation. A leading marketer and developer of personal computer software, DATASOFT offers experienced assembly-language programmers the opportunity to join their staff to develop and translate arcade games such as ZAXXON™, as well as to author original material for their games, education and home management product lines. DATASOFT pays competitive salaries, plus bonuses based on product performance. Relocation assistance is available, if needed.

If you have working knowledge of Atari, Apple, TI, or Commodore operating systems, graphics, animation and sound, call or write Melinda Storch at:

**Datasoft Inc.**  
COMPUTER SOFTWARE

9421 Winnetka Ave.  
Chatsworth, CA 91311  
(213) 701-5161 / (800) 423-5916

ZAXXON and SEGA are registered trademarks of Sega Enterprises.  
DATASOFT is a registered trademark of Datasoft, Inc.

Circle No. 20

### Boulder Logical Testing, Inc. is now offering a new EPROM Programmer FOR \$195.00

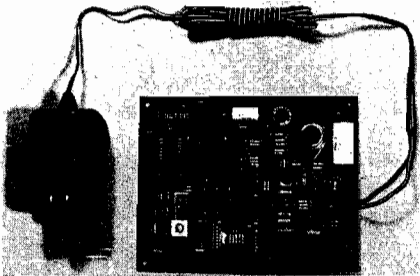

- Microprocessor based
- Programs 2716, 2732, 2732A and 2532 EPROMS
- Zero Insertion Force (ZIF) sockets are standard
- 25 or 22 volt programming voltage option
- Copy from EPROM to EPROM automatically
- RS 232 interface with selectable baud rates
- Thorough user documentation includes example software drivers for popular computer systems, including Apple\*, IBM PC\*, and CP/M\*
- Command set can be used from host computer or terminal
- Comes complete with power supply

To order, or for more information write:  
**Boulder Logical Testing, Inc.**  
PO Box 902  
Boulder, CO 80306

Ordering information: send money order or check only, no CODs. Price includes shipping costs and documentation. Colorado residents include 3% sales tax.  
\*Apple is trademark of Apple, Inc. IBM PC is trademark of IBM, CP/M is trademark of Digital Research.

Circle No. 21

## CoCo Bits *(continued)*

radioteletype modem, next to my ham radio, sandwiched between the disk drives. I have had a lot of fun with it, and gained some practical use by accessing the local bulletin board and the educational timesharing network available in North Dakota. I suppose a subscription to CompuServe will be next.

A new accessory available for CoCo is a video monitor output adapter. This device connects to CoCo's RF output and delivers a high-quality signal to a standard video monitor. There is no modification required to the computer, and it should provide an excellent video signal. Flex, in its 64 character-per-line mode, will be the test of this promising new accessory. Though color graphics are nice, the color TV is a poor monitor at best. Any improvement along this line would certainly be welcome.

I have a new drive unit on line and am happy with it so far. It is an MPI from Frank Hogg Labs. Though noisier than my Radio Shack drive and slightly longer, its color and style fit well with the system. The drive, a 40-track unit, allows me to read Flex files written on 40-track disks.

Flex allows you to specify different system and working drives. For example, the DOS will keep track of the fact that drive 0 might be 35-track double density, while drive 1 is double sided, double density, 80 track. That information is stored in the directory, which is always written in single-density format. By allowing different drive styles, a much greater compatibility is possible.

While on the subject of Flex, I must comment on the ease of getting printed information from files. Flex allows all commands to be prefaced with a P, which will send all file output to a printer. Flex allows you to change the baud rate from 110 to 9600. You may choose a carriage return plus line feed, or the standard Radio Shack carriage return where the printer must send its own line feed. You may set the number of stop bits as well.

### Service Manuals

In the last few weeks, I have received several letters regarding the availability of service manuals for the CoCo disk drive units. Radio Shack Computer Center managers are informing people that manuals are not available. There are two manuals covering the disk units — one covers the drive and the other the drive controller card. The part numbers for the manuals are MS-260-3022 and MT-260-3022 respectively. The pair costs less than \$10.00. According to a local store manager, these manuals are available from Radio Shack National Parts Division. If you provide your dealer with the above data, you should have no trouble obtaining them.

Next month I will have more comments on using Flex, Star-DOS, and other CoCo operating systems.

Contact Mr. Steiner at 508 Fourth Ave. NW,  
Riverside, ND 58078

**MICRO**

**valFORTH™** for Atari® 400/800  
Professional Software for the Hobbyist

FORTH has been used for years by ATARI® and others in programming their arcade games. FORTH is *fast*, 15-20 times faster than BASIC, and can make use of every capability for your computer. And it's no longer the province of the professional programmer! With valFORTH and the additional packages described below, you can create programs in an afternoon that would previously have taken weeks of hard work!

WHAT? YOU DON'T ALREADY KNOW FORTH?

Then take advantage of our special offer on *Starting Forth* by Leo Brodie. Widely acclaimed as the best book available on the subject, this entertaining treatment of Forth will make you comfortable with this exciting language quickly and easily. When you order *Starting Forth*, you get a free copy of our "Notes for the valFORTH User," including references, by page, to *Starting Forth*.

These are the utilities developed by Valpar International's software specialists and used to create our commercial software products.

**valDOS** NEW! By Popular Demand!

valDOS. Now you can use your valFORTH system to read and write normal Atari DOS Files created with valDOS or other sources. Also includes valDOS File Editor for creating and reading FORTH Source Code without "screens." (Not a general file editor.)

(Over 25 pages of documentation. Requires valFORTH.)

**valFORTH™**

Package contains: fig-FORTH kernel with mathematical and stack operations machine-coded for higher speed than normal fig-FORTH; line editor AND screen editor, debugger, sound and graphics commands, floating point, advanced 6502 assembler, diskcopiers, and much more! (Over 110 pages of documentation)



**GENERAL UTILITIES AND VIDEO EDITOR**

Utilities: 4 array types, 4-case types, text on graphics 8, extensive string manipulation and keyboard input, STICK & PADDLE, randoms, bit manipulation, and much, much more.

Editor: *fast, powerful, complete* valFORTH screen editor 1.1. A professional-quality tool that makes editing a pleasure.

(Over 60 pages of documentation. Requires valFORTH.)

**PLAYER-MISSILE GRAPHICS, CHARACTER EDITOR, & SOUND EDITOR**

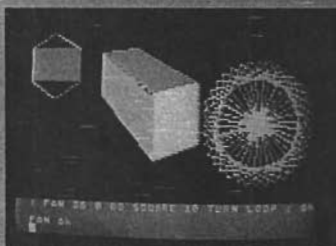

Player-Missile: Create, move, color, change images of and bound players and missiles with high level commands. Full support of 5th player, multicolor players, etc. etc. All critical sections in machine code. Character Editor: Compose character sets with joystick. Simultaneous display of created characters. Make images for players and missiles.

Sound Editor: Simple independent control of all four voices (one joystick per voice) and audio-control register. Create any single-setting sound with graphical and tabular readout.

(Over 35 pages of documentation. Requires valFORTH.)

**VALPAR INTERNATIONAL**



Coming Attractions:

- \* TARGET COMPILER
- \* 3D WORLD

For more information *fast* and a **4TH ♥ IF HONK THEN** bumpersticker, send 25¢ and a self-addressed, stamped envelope.

**DISPLAY FORMATTER**

Fast, simple creation of all types of display lists, with automatic 4K boundary jumping. Automatic or user controlled memory allocation, and formatting for horizontal and vertical scrolling, and display list interrupts.

(Over 30 pages of documentation. Requires valFORTH.)



**TURTLE & valGRAPHICS AND ADVANCED FLOATING POINT ROUTINES**

All graphics modes supported — even GTIA and "7+ ". Draw and fill commands *faster* and *smarter* than Basic. "Turn-toward" for "chasing" and vanishing point effects; point labeling, etc. Also SIN, COS, ATN, ATN2, etc. added to floating point.

(Over 35 pages of documentation. Requires valFORTH.)

**Text Compression and Auto Text Formatting**

A unique, two-part utility!

- Text Compression allows the packing of text into much less space than normally required. Useful for wordy Adventure games, "artificial intelligence," etc.!
- Auto Text Formatting takes both normal and compressed text and routes it to the video screen "windows."

(Over 20 pages of documentation. Requires valFORTH.)

valFORTH alone requires 24K  
valFORTH plus one or more packages requires 32K minimum  
Memory requirements include 10-12K working space  
All products are now on non-protected disks  
Over 350 pages of detailed documentation!

valFORTH 1-1	\$59.95
General Utilities and Video Editor	49.95
Player Missile Graphics, Character Editor, and Sound Editor	49.95
Display Formatter	39.95
Turtle and valGraphics and Floating Point Routines	54.95
Text Compression and Auto Text Formatting	39.95
valDOS and valDOS File Editor	59.95
Heavy-Duty Professional Binder (provided free when ordering 3 or more packages at one time)	13.00
Starting Forth	15.95

VALPAR INTERNATIONAL  
3801 E. 34TH STREET  
TUCSON, ARIZONA 85713

Call Toll-Free 800-528-7070 In Arizona call (602) 790-7141

Principal Software Authors: Stephen Maguire and Evan Rosen

Atari is a trademark of Atari, Inc., a division of Warner Communications.

Plus Shipping and Handling  
VISA and MASTERCARD accepted

Circle No. 17



# THE ATARI 1200XL

by Paul S. Swanson

**D**ifferences between the Atari 1200XL and earlier 400 or 800 computers are significant. The most obvious difference is the physical appearance. The case design is sleek, particularly in comparison to the 400 and 800 systems. The keyboard is similar, but the two most troublesome keys have been moved off the main keyboard. These two keys are BREAK, which can accidentally stop a program running on a 400 or 800 if you miss BACK S by one key, and the Atari key, which inverts the video output if you miss the question mark by one key. These two keys have moved up to the metal strip above the keyboard.

There have been five keys added to the function keys available on the 400 and 800. One is the HELP key, which can be strobed by a program to sense user distress or any other defined symptom. There is also a built-in demo program in the 1200XL that uses the HELP key to control its functions.

The other four keys, F1 through F4, can be used in combination with SHIFT

and CONTROL (renamed from the 400 and 800 CNTL) to provide a total of 12 keyboard-initiated functions. With no SHIFT or CONTROL, these keys act like the arrow keys do with CONTROL down, so they contribute single key-stroke cursor control. With SHIFT down, the four keys add four additional cursor controls. SHIFT F1 will move the cursor to the upper left corner of the screen, SHIFT F2 to the lower right, SHIFT F3 to the beginning of the physical line, and SHIFT F4 to the end of the physical line.

CONTROL with these four function keys creates more involved functions. CONTROL with F1 locks out the keyboard, which can be restored by pressing the same combination again. CONTROL with F2 turns off the video display, which is restored by pressing any keyboard key. CONTROL with F3 toggles between keyboard click and no keyboard click. CONTROL with F4 changes the character set to the new built-in international character set.

Atari omitted the cartridge door

from the 1200XL. This welcome change circumvents the physical weakness of the 400 and 800 case designs. The only part on my 400 or 800 that has ever failed is the cartridge door hinge, a problem I don't anticipate with my 1200XL. The cartridge has been moved to an open slot on the left side of the computer. This should provide many possibilities. With no cover containing the cartridge, larger cartridges (actually external to the computer) can be constructed that bypass the restrictive size constraints of 400- and 800-compatible cartridges. A slight alteration of dimensions on the cartridge slot may make some third-party cartridges incompatible with the 1200XL, but all of the Atari-produced cartridges will work easily.

The rest of the external accessories on the 1200XL are identical to the ones on the Atari 800 except that there are only two controller jacks on the 1200XL and four on the 800. There is a monitor jack as well as a modulator for connection to a television, a serial port jack, and the selector for channels 2 or 3.



### Operating System Improvements

As indicated by the four function keys, there have been operating system changes. The international character set, implemented by CONTROL with F4, replaces the keyboard graphics characters with a set of 29 international characters with diacritical marks with the letters as well as the British pound and inverted exclamation point. As with the 400 and 800, you can also invent your own character set. L2, which is a LED indicator on the keyboard, lights when the international character set is selected.

The keyboard click is no longer produced by the keyboard. All of the functions are still possible, but they are channeled through the television speaker. When the keyboard click is suppressed, all of the other sound channels still operate normally.

Turning off the video display can speed up processor time by about 25%, which is done by eliminating DMA (Direct Memory Access). The real-time clock (which does exist on all Atari

computers, contrary to Commodore's advertising claims) continues to run, so the vertical blank interrupt is still in operation with this function implemented. From timing loops that I ran on both the 1200XL and on the 800, it appears that the vertical blank interrupt has also been rewritten and runs faster on the 1200XL.

The additional memory that was added to bring the 1200XL to 64K is bank selected into the 6502's address space. This implementation excludes direct access to the additional memory from BASIC; however, it can be utilized by machine-language programs and subroutines, including those called from BASIC.

Although I have no documentation on it, I believe the video output circuitry has been improved on the 1200XL. The colors are brighter and the contrast is sharper. In switching from normal television viewing to using the 1200XL in the normal text mode, I have found it necessary to turn down the contrast significantly or set color

registers 1 and 2 closer together in luminance.

The locations used to read and write controller ports 3 and 4 on the 400 and 800 are redefined on the 1200XL. These locations (Port B) are used to implement, under program control, the new features available from the four new function keys. The other new LED, L1, is lighted when the keyboard is disabled. Writing to the Port B registers controls L1 and L2 the way the function keys would. Port B also controls the bank selection options.

Another operating system enhancement is the addition of four graphics modes. All four of these new modes are actually available on the 400 and 800, but can be declared by a GRAPHICS statement from BASIC on the 1200XL because they are operating-system supported. To implement them on the 400 or 800, you must build your own custom display list.

The four modes include two character graphics modes and two map modes. You must build and locate in

# MEGAFLEX<sup>®</sup>

# ABILITY

## *You Pick The Disk System, MegaFlex Controls It!*

### WITH SOFTDRIVERS FOR A FLEXIBLE FUTURE!

MEGAFLEX—a universal floppy disk controller and modern alternative to the Apple drive system offering increased storage, improved reliability and . . . FLEXIBILITY.

Enjoy megabytes of online storage with your choice of micro, mini, or maxi drives—or even 6Mb with the Ailyn cartridge pack! Ideal for high-capacity storage now, winchester-disk backup later.

The MEGAFLEX secret is to autoboot soft-drivers that match the needs of your drive system. All hardware functions are software-controlled. MEGAFLEX can match new drive capabilities without hardware changes. Drive-dependent ROMs have been eliminated.

### APPLE III? OF COURSE!!

MEGAFLEX is compatible with BASIC, CP/M, Pascal, VISICALC, SOS and DOS-emulation on the Apple III, Apple II, Franklin Ace and Basis. All language features and operating system commands (LOAD, BRUN, etc.) are standard. If you can operate Apple drives you can operate MEGAFLEX! Your Apple software will run without modification too.

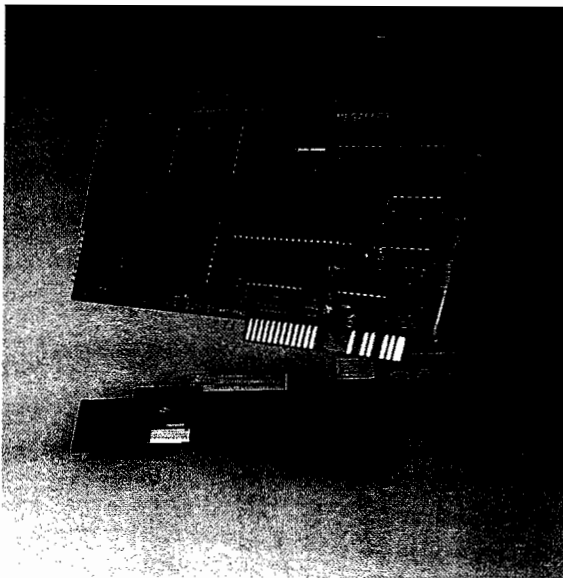

### BRIDGE THE APPLE FORMAT BARRIER!

The MEGAFLEX diskette does what Apple's cannot—read and write diskettes from other computers! Software-controlled industry-standard IBM 3740 or System 34 type formats allow the MEGAFLEX library of reformatting software to read and write Altos, Radio Shack, Osborne, and IBM PC diskettes. (Call for the latest software details.)

### MORE STORAGE, MORE

### UNIVERSAL FEATURES, LOWEST COST

MEGAFLEX with 8" maxi or high density 5.25" minis gives you 1.2 Megabyte of formatted data per diskette for 8 times the file and data size!

MEGAFLEX offers flexible software choices:

- data rate (250/500 Kbits per second),
- single and double density recording, and
- single/double sided drive operation (max 4 drives).

MEGAFLEX has the lowest chip count of any controller today! This means less power, a cooler Apple and better reliability.

Lowest price, highest performance, that's

MEGAFLEX!

11722 SORRENTO VALLEY ROAD  
SAN DIEGO, CA  
(619) 452-0101  
TWX 910-335-2047 APPLE TWO SDG

# MEGABYTER<sup>™</sup>

A Division of SVA

TRADEMARKS CP/M—Digital Research



memory a character set when using the character graphics modes. The character set information is interpreted the same way bytes on a four-color map mode display are interpreted except that, when the character is printed in inverse video, bit combination 11 uses register 3 instead of register 2. Although much of the literature from Atari that deals with these two modes calls them four-color modes, they are actually five-color modes, restricting each character to four of the colors. The colors for each character are background (register 4), register 0, register 1, and either register 2 or register 3.

The new map modes are 160 x 192 dot displays. One is a two-color mode and the other is a four-color mode. The addition of these modes means that all of the internal IR modes except one are now operating-system supported. The one that isn't is a variation of mode 0 using ten scan lines per character line instead of the eight used in mode 0. This enhances the appearance of the characters by allowing two extra scan lines for the lower-case descenders. Judging by the number of programs that I have seen using this mode, the demand may dictate that Atari may never bother to support it in their operating systems. It can produce nice output, but mode 0 is usually considered good enough.

### Concerning the Competition

This new offering by Atari is not without competition; for example, the Commodore 64. The Commodore system is a sophisticated assembly of electronics, implementing several of the same features implemented by the Atari computers. The Commodore has more and larger sprites than the Atari's player/missiles. The Commodore has three sound channels as opposed to the four in the Atari computers, but the Commodore has more controls for attack and decay as well as finer selection of frequency. However, the sound channels on the Atari computers are more capable of producing sound effects.

There are 16 colors available on both the Atari line of computers and the Commodore 64, but the Atari computers also give a selection of luminances. Correctly written graphics routines on the Atari have much more depth than routines written on computers such as the Commodore 64 and Apple because of these luminances.

The Atari display output is also

more in tune with the television — the normal video output in the home where these computers are intended to be. There are only 160 color clocks across the visible area of a standard color television. This makes it physically impossible to have a selection of two different colors for the text mode if 40-character lines are used. If you have a Commodore 64 and you try to select certain combinations of color for the text mode, every other letter will be illegible because the television cannot display the number of color clocks required. The Atari text mode uses one color with two luminances for the characters in the text mode with at least two dots for the width of each dot or line in the characters. This makes

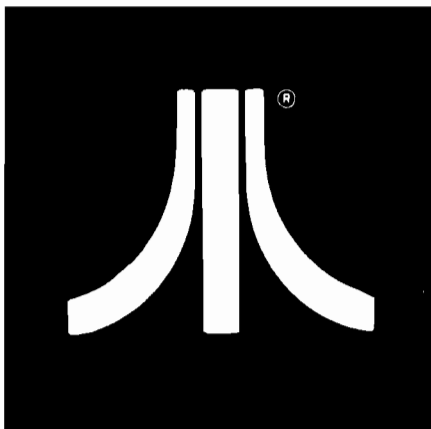

the Atari characters appear shorter and fatter than the characters used on other computers, but also makes them much more legible because the method used on Atari is more consistent with the way the television processes the signal.

### New Peripherals

No drastic physical change in appearance would be complete without color-coordinated peripherals. Already available is the Atari 1010, which is an upgrade of the Atari 410 Program Recorder (cassette drive). The case is consistent with the design of the 1200XL and the internal circuitry has undergone a few improvements. Some existing cassette-based programs may give you problems on the 1010 and 1200XL combination, but Atari includes a notice in the literature supplied with the 1200XL that promises to solve any problem you may have with APX cassette programs, free of charge, of course.

Available in the second quarter, possibly by the time you read this, are two new printers. The Atari 1020 is advertised as a 40-column color printer. It uses multicolored pens to plot letters and/or graphics. The Atari 1025 is an 80-column printer that does not require the 850 interface. I have been told that it does not have graphics nor some of the other fancier options afforded by third parties (I'll be keeping my Epson MX-80 with Graphtrax Plus), but not requiring the 850 makes its suggested retail price of \$549 very attractive for 80 columns of printed output. Other 80-column printers may have similar prices, but require an additional \$200 for the 850. Other new peripherals are expected in the near future.

### Looking Ahead

Atari will be announcing new computers in June. Although not much has been released officially, two new computers, called the 600XL and 800XL, are expected. The new computers will have BASIC as a built-in feature according to the sources I have tapped for information.

Rumors concerning the new computers should not be trusted, but are interesting. I have heard mumblings of built-in speech synthesizers and modems. If these prove to be true, I would say that Atari is making real progress in advancing the quality of home computers. The internal graphics circuitry used in the Atari seems to be, by far, the most advanced available in any computer in the same price range.

Third-party suppliers should become very active in producing new peripheral devices for the 1200XL. Although this computer has been criticized for being a "black box" with no open circuitry that the true hacker can start cutting up and rearranging (probably one of the stronger selling points for the less sophisticated Apple computer line), the 1200XL actually offers something not easily available on the older Atari computers. The open cartridge slot has 13 of the 16 address lines with a select line governing the other three, all eight data bus lines, and several other control lines available. Little imagination is required to think of what can be done with this slot.

*You may contact Paul Swanson at 97 Jackson Street, Cambridge, MA 02140.*



# New Microprocessors for Your Apple II

by Phil Daley and John Hedderman

**D**o you feel left out? Does everyone seem to have a new computer but you? You can have a new computer without selling your old one.

There are several add-on boards for the Apple II that increase its capabilities, provide new features, teach you new languages, and allow you to run software written for processors other than the 6502. We discuss several of these boards: the Excel-9 6809 by Norell Data Systems, the Mill 6809 by Stellation II and the Dtask Grounded 68000. We have also been working with an Apple III and will present a short summary of its features.

Let us start off by saying that we like the Apple II and the 6502 microprocessor and have not found serious deficiencies in either. However, after using a 6809 microprocessor, you cannot help but be impressed with the increased capabilities of the 'cadillac' of 8-bit microprocessors. Just having 16-bit registers makes a large difference in programming ease, and being able to long branch to any portion of memory makes writing location-independent code a snap. When you add on the power of a structured operating system like OS-9, the results are dramatic. Certainly no one will argue the advantages of a 68000 microprocessor. With 32-bit registers and a 12.5 MHz clock, the speed differential on identical code is enormous. When you add the programming ease and addressing capability of the 68000, you have amazing potential.

## TSC's Flex

The Excel-9 board comes with the complete FLEX manual from Technical Systems Consultants and is well written, easy to understand and complete. Unfortunately the Apple documentation from the Norell people was written in Japanese and translated into English, or at least that's the way it reads. The documentation is somewhat sketchy but gives a satisfactory explanation of the setup and operation of the Excel-9 board.

The first step in using a new disk is



to always make a backup before something disastrous happens. To format a Flex disk, a program called NEWDISK is executed. We typed in 'NEWDISK 2' to refer to formatting a disk in Apple drive 2. Unfortunately that did not work, as a 'DRIVES NOT READY' error message was displayed. Apple normally calls the drives in each disk controller card '1' and '2'. The slot number of the controller card and the drive number of the disk are necessary to completely specify the desired drive. Flex numbers the drives, starting with '0', and continuing in sequence. The Apple drive #1 is considered as Flex drive #0 and Apple drive #2 is Flex drive #1. This is probably less confusing than the CP/M system of Apple drive '1' being CP/M drive 'A'.

Typing 'NEWDISK 1' successfully formatted a blank disk. All commands in Flex are executed by typing the program name. The documentation says to make a backup the proper command is 'BACKUP'. When we typed 'BACKUP', a 'NOT FOUND' error was received. A quick CATALOG of the disk revealed a COPY command, and by typing 'COPY 0,1' produced a backup of the Flex master disk. Next we 'LINKed FLEX' to produce a bootable disk. The

bootstrap program has to know physically where the system DOS resides on the disk, and the program LINK stores the starting track and sector of FLEX.SYS in track 0, sector 1 so that upon booting a disk, the boot program can load Flex into memory.

All of the normal Flex utilities are included on the system disk, and they all work as specified in the Flex manual. Using the LIST, ASN, CAT, etc., commands produced the standard Flex results. To try the 'P' command, you attach a regular printer cable to your interface and printer, we used an Epson MX-80 with the Apple serial card. Typing 'P,CAT 0' produced a hardcopy catalog list.

To delve a little deeper into the innards of Apple Flex, a sector read utility was used to examine the backup copy of the Flex system disk. The track and sector linking that Flex uses to access the sectors in an interleaved fashion seemed to be rather haphazard and not sequentially as on other 6809 computers. It appears that the Apple NEWDISK writes the sectors in a physically sequential process and then links them ahead four or five sectors to optimize access speed, whereas Flex on a regular 6809 computer interleaves the



sectors as it writes them, and then links them in a logically sequential process. This difference prompted us to write a test program (see listing 1), a Flex utility to change the name and number of the Flex formatted disk that is stored in the system information record, using the Flex Advanced Programmers Manual. This program was written and tested on a standard 6809 computer first and then retyped, with no changes, into the TSC Text Editor supplied on the Apple Flex disk.

The program reads the System Information Record (one sector) by calling one of the Flex user routines and, after making the appropriate changes to the information, writes the sector back, referring to its track and sector (Track 0, Sector 3). By employing two different methods of accessing the disk, we gave the system a double test. Each method worked even though the track-sector reference to the disk sector was not the Apple disk sector referenced. Apparently Flex on the Apple translates this difference internally.

The Excel-9 board also has a basic system monitor, which we used to examine some memory. The monitor can do things like Dump, Disassemble, Jump, Compare, etc. One note: when within a monitor command, the documentation doesn't mention the accepted method of return to the command mode. (Reset works, but it's messy.) A {space}{return} seems to work most of the time.

The Excel-9 board works very well and fully implements the Flex operating system on the Apple. It worked without flaw on our Apple II. We couldn't use it on our Revision 7 Apple II without removing the Apple serial card from slot 1. Norell is aware of the problem and is working on a cure. If you want to learn about Flex, the Excel-9 is the board for you.

### Stellation II's Mill

Standard software for the Mill, a 6809 board, includes a macro-assembler and debugger for writing machine-language programs on the 6809. Included is a demonstration package for multi-processing — running the 6502 at 1/5th speed and the 6809 at full speed at the same time. Also available is a Pascal speed-up kit to increase the operating speed of Apple Pascal. The multi-tasking operating system, OS-9, is available from Micro-ware and includes a structured basic,

BASIC09, a sort of hybrid with Pascal.

The documentation that is packaged with all parts of the Mill system is complete, understandable, and well written. But learning an entirely new operating system requires effort on your part. OS-9 is a 'Unix-like' hierarchical tree-structured system and, as such, takes someone who is used to a simple system like Apple DOS a while to get the hang of it. More on Apple operating systems in next month's magazine.

McMill is a powerful Macro-Assembler that comes with the Mill. It would be very useful for developing software for other 6809-based computers with more limited development systems; eg., the TRS80-C.

To test the assembler for the 6809 Mill, we tried a bubble sort program (see listing 2) from a programming manual. Any normal text editor that makes standard DOS text files can be used to write the assembly file. We

vectors is overcome. Since the Apple vectors are in ROM, there would be no way to change them for the 6809. Inverting the addresses places the 6809 vectors at the top of the \$7000 (physical) addresses.

The address inversion also creates another problem. The Assembler creates the code at the ORiGinated address. The output of the Mill Assembler is a text-type file of hexadecimal code. A program called 'LOAD09' is a utility on the assembler disk that loads the created file into RAM memory. Unfortunately, it will also try to load the program into ROM or DOS, anywhere the program was ORG'ed. Since this leads to system crashes, it is necessary to ORG the program somewhere in Apple RAM that is available. Then the program must be BLOAded and called at a different address, such as the inverted one. Those of you who have been following closely will see that this places definite constraints on the ad-

**McMill is a powerful Macro-Assembler that comes with the Mill. It would be very useful for developing software for other 6809-based computers with more limited development systems...**

used Apple Writer as it is one of the few that is DOS compatible and doesn't word wrap when you don't want it to. After removing the errors due to erroneous labelling, the file assembled correctly. The question arose as to the proper ORiGination, not covered in the manual. The Mill uses addressing which is \$8000 relative to the Apple addressing due to conflicting areas of memory. We tried \$A000 (assuming that would translate to \$2000), which placed it in memory at \$A000, the middle of DOS: this crashed the system, so we tried \$2000.

This address inversion is the trickiest part of using The Mill. Since having two processors addressing the same RAM memory can cause conflicts, The Mill inverts the most significant memory address bit (A15) prior to being placed on the Apple memory address bus. This means that there are both 'logical' and 'physical' names for each memory location. The physical name is the actual RAM address in the Apple, the logical address is the inverted address that the 6809 thinks its using. In this manner, the conflict with high memory interrupt

addressing modes of the original program. The bubble sort program was then rewritten to use only Program Counter Relative addressing to result in a position independent program that can run anywhere in memory. The 6809 assembler makes it very easy to write position independent code, calculating all the relative offsets to the PCR.

A call to the Mill people prompted the suggestion we try \$7FFE as the origination point with the first two bytes of zero to overwrite the interrupt vector. That would place the program at \$8000 (relative \$0000). This is probably the most satisfactory solution.

'MUG' is a program to interactively run and debug 6809 programs. It includes memory dump and disassembly listings, breakpoint insertion, memory search and modify, register change and dump and a calculator mode. It is easily modifiable so that the Mill can reside in any slot. (This is starting to become a problem with all these add-on cards cluttering up our Apple.) The program and documentation are easy to use and, once you overcome the address inverting, easy to understand.

The Mill also has demonstration



programs of the two processors running concurrently. While it is most impressive, it would take some time to learn how to make the best use of this feature.

Another set of programs is the Pascal speed-up kit. This group of files substitutes for the SYSTEM.APPLE and SYSTEM.MISCINFO files on APPLE1: and requires the Mill to be present in the Apple when operating. The directions are clear and established the files on our newly made APPLE1: (now called MILLO9: so that we don't get it mixed up). The speed difference is quickly apparent. You can even specify a screen print of which processor is running at the current time, although it didn't

(optional drive number), object file name (default 'source name.OBJ0') and printer slot (default 0 for monitor). The listing format is relatively neat except that comments over 18 characters long wrap around to the next line (on an 80 column printer) and make the listing harder to read.

The assembler disk comes with an upload and monitor programs so that you can learn and try out 68000 code running on the Dtack board. Unfortunately the documentation on the upload and monitor portions is incomplete and hazy. Producing the object code proved to be much easier than uploading it to the 68000 board. We first tried the 'UPLOAD' program sup-

After several program changes/runs and no results, we tried modifying the registers directly with one line programs. When this also gave no changes, we gave up on the Phase-0 monitor program. There seems to be a problem with either the register dump or the execution command.

Using the Monitor that is in the Bootstrap ROM of the Dtack board, while a more complicated procedure, produced better results. We examined the sample programs included with the Dtack board and determined the proper procedure for executing a program on the board. It includes loading the FP BASIC from Dtack on the language card, uploading the file, executing the file and ending with a register dump to view the results (see listing 4). The REM statements are ignored by the Applesoft interpreter and used by the Monitor program as data codes. In this manner, data can be transferred from the Dtack board to the Apple, and vice-versa. There are other CALLs to perform other functions as well. We also discovered the opcode 'TRAP #15', which dumps the 68000's registers and exits the program. TRAPPING to vectors 0-14 can provide other exits and routines by changing the vector pointers. In any case, using the Monitor program from BASIC works quite well.

The Dtack board has tremendous potential but requires knowledge of the user. It has the most primitive software at this point, but also the most potential for future development.

### Apple's III

For those of you who like the 6502 but want a system with more features, there is the Apple III, the most sophisticated 6502 computer that we've seen. It contains the best elements of the Apple II with improvements of many of its shortcomings, and has additional features not found on many systems in its price field. In as much as we have heard the bad reviews that followed its release, and that we like the Apple II even with its faults, we awaited with trepidation the arrival of the III, and have somewhat procrastinated the testing and experimentation necessary to write this review.

The folks at Apple need not fear, however, as we liked the computer more than we thought we would and, indeed, if not for its price tag, would be tempted to buy one. The question remains whether a 'personal' computer

**...for those of you who like the 6502 but want a system with more features, there is the Apple III, the most sophisticated 6502 we've seen.**

show until we turned off the 80-column card.

This is the smoothest running board we tested with the least bugs and best software. It is also the only unit tested that includes software for Pascal. The complete outfit including OS-9, while expensive, is probably the most useful adaptation for the Apple.

### Dtack Grounded's 68000

If you are adventurous and want to experiment with a fast micro-processor, Dtack Grounded makes a 68000 board that is compatible with the Apple. The connection instructions are simple (the board plugs into slot 2) and the demonstration programs are impressive and work flawlessly. A cross-assembler is available from Phase-0, and it appears to work correctly.

Again, it is necessary to use a text editor to make the file (see listing 3) before assembling. The editor must supply carriage returns at the end of each line. ASSEM68K has several non-standard requirements such as: it uses an 'ASC' pseudo-op instead of 'DC' for ASCII characters, it requires a ';' for comments, and it does not allow an 'END' statement. The Phase-0 documentation does mention the first two, it does not mention the third. The operation of the actual assembly is easy; it only requires a source file name

plied on the Phase-0 disk. The program does not handle extra DOS parameters, such as drive number. We had to LOAD, CATALOG, and RUN to read from a second drive.

Next we used the MONITOR program to look at memory. At first we couldn't find the uploaded program and made a quick call to Dtack Grounded. Mr. Hardenburg told us that the upload program loads the program into the Dtack board wherever it is organized. He also gave us a quick memory map, not included in the documentation to help in deciding where to write programs. \$0 to \$1000 is the bootstrap program, from \$1000 to \$10FF are the RAM vectors, and from \$1100 to \$1EFF is the system stack, building down. Therefore \$2000 is a safe place for programs with scratch space in the \$1100 area.

Since we had ORiGined the program at \$1000, it had been overwritten by the RAM vectors. Setting the ORG to \$2000, uploading the code and running the monitor program found the program intact and residing at its proper location. The next problem was how to gracefully exit from the program. We tried JuMPing to \$122, the monitor input idle. Upon execution, the program returned to the monitor and we dumped the registers. Unfortunately, they showed no results; in fact, except for the Stack Pointer [A7], none had changed at all.



would need all its features and memory, and it is probably better suited in a business atmosphere.

The Apple III has a built-in disk drive that is much quieter than the old Apple drives. We have recently seen some new drives for the II that are much quieter and more professional sounding. They all seem to work quite reliably however. It also has an RS-232 serial port, two ports that support two analog and two digital devices, B & W and color video ports and an external speaker plug. The III runs on SOS (Sophisticated Operating System), one of the two biggest improvements over the II. It is a system reminiscent of the II's Pascal environment (which it is written in), including its exasperating file names, but it is much better than DOS and CP/M.

There is a standardized interface for all block and character devices, and each device is named and configurable. There is a Utility Configuration program to set up initial parameters and to save your personal configuration to disk. Then, assuming you don't buy any additional hardware, you transfer that file to all your disks that you want to boot and you are all set. We added a Vista Timecard III to our system in about ten minutes, faster than it took us to learn how to set the right time after it was connected. The Timecard is accurate to several seconds per week.

The file system uses pathnames and supports multiple hierarchies in the directory system, a branching tree file structure. Fifty-one files can be entered in a volume file directory, but there can be 1663 sub-directory entries on that volume. File names can be 15 characters long, something we never thought much about on the II, but having worked more on a Flex system allowing only eight characters per name, we really appreciate additional file name lengths. Pathnames can be up to 128 characters.

The other major improvement is in the console, CRT display. Not only does the III standardly display 80 characters per line, upper and lower case (the biggest defect in the II), but also the character set is in RAM, leading to user-definable character sets. In fact, Apple supplies several fonts on the Apple Writer III and Business BASIC disks. We found it fascinating to write an example in Gothic font. While we can't think of any real use for a Gothic font, we could definitely see some uses for math symbols and Greek letters. The keyboard also supports

type-ahead (no use to someone who types as slow as we do) 128 character codes directly generated from the keyboard (256 if you count the 'open apple' which sets the high bit of all keys on the keyboard), a numeric keypad, and all keys repeatable if held for more than 1/2 second. We especially like the two-speed cursor control keys, which go faster if you push down harder.

The Monitor III that came with the system is the best green monitor that we've seen — crisp and clear. However, the idea that 'normal' is black letters on a green screen and 'inverse' is green letters on a black screen must have been thought up by someone not connected with reality. Actually, in deference to us computer types, the default condition is 'inverse'.

The Apple III appears to us to be a smooth working machine, but too expensive to be a home computer. It is more appropriate than the Apple II for business use.

Apple III  
Apple Computer Co., Inc.  
Cupertino, CA 95014

## The Apple IIe

*So what about the IIe!* We can hear the questions now. Also, we get telephone calls several times a week asking what are the differences between the II+ and the IIe. Unfortunately, we have not received a product for review. The most important things to determine, such as the changes to the F8 ROM, will have to wait until we can do some experimentation or until some of our readers who own a IIe write in to let us know the differences.

The reviews and our personal observation point out that the structural changes, while major in fact, are minor in operation. To someone who uses a II+ with all the trimmings (a language

**So what about the IIe? The reviews and our personal observation point out that the structural changes, while major in fact, are minor in operation.**

All the products reviewed lived up to our expectations; some can make your Apple do things you wouldn't have dreamed possible. If you want increased performance or to learn about new microprocessors, you don't have to buy a whole new computer.

### Manufacturers' Addresses

Excell-9  
Norell Data Systems  
3400 Wilshire Blvd.  
P.O. Box 70127  
Los Angeles, CA 90010

The Mill  
Stellation Two  
P.O. Box 2342  
Santa Barbara, CA 93120

Dtack Grounded  
Digital Acoustics  
1451 E. McFadden, Suite F  
Santa Ana, CA 92705

ASSEM68K  
Phase Zero, Ltd.  
2509 N. Campbell Ave. Suite 130  
Tucson, AZ 85719

card, an 80-column board, etc.), the changes will seem minor indeed. The keyboard layout is similar to the III and we never did get comfortable with that. Not having the double quote over the '2' really slowed down my already snail's pace typing rate. We did like the cursor keys, however.

Most software seems to run OK; the original figure of 85% appears to have been a major understatement designed to shock the software community. Unless a routine uses strange entries into the Monitor ROM, the programs should run OK. Eight-column boards are strange creatures, being completely incompatible with each other, so don't expect all programs for an 80-column board to work on the IIe. They wouldn't run on a II+ without the specifically designed board, either.

We promise a more technical in-depth report on the exact changes when we are able to get that information. If anyone has a IIe, write us about the changes. We know that the binary-language loader is certainly faster than the old system master 'HELLO'.

*(Continued on next page)*



Listing 1: Flex Example (Assembly)

FLEX ASSEMBLY LANGUAGE PROGRAM : NAMEDISK FOR FLEX ON THE APPLE

```

* DISK RENAME/RENUMBER
*
* COPYRIGHT (C) 1982
* THE COMPUTERIST, INC.
* 34 CHELMSFORD STREET
* CHELMSFORD, MA 01824
* ALL RIGHTS RESERVED
* USER-CALLABLE ROUTINES

000C WKDRV EQU $000C WORK DRIVE LOCATION
CC14 LINBUF EQU $CC14 LINE BUFFER POINTER
C003 WARMS EQU $C003 DOS WARMSTART ENTRY
CD15 GETCHR EQU $CD15 GET CHARACTER
CD18 PUTCHR EQU $CD18 PUT CHARACTER
CD1B INBUF EQU $CD1B INPUT BUFFER LINE
CD1E PSTRNG EQU $CD1E PRINT STRING
CD27 NXTCH EQU $CD27 GET NEXT BUFFER CHARACTER
CD39 OUTDEC EQU $CD39 OUTPUT DECIMAL NUMBER
CD3F RPTERR EQU $CD3F REPORT DISK ERROR
CD48 INDEC EQU $CD48 INPUT DECIMAL NUMBER

* FMS EQUATES

D403 FMSCLS EQU $D403 FMS CLOSE
D406 FMS EQU $D406 FMS CALL

* SYSTEM EQUATES

C840 FCB EQU $C840 SYSTEM FCB
C841 ERLOC EQU FCB+1 ERROR NUMBER
C843 FCBDRV EQU FCB+3 DRIVE NUMBER

* MAIN PROGRAM

                ORG $C100

C100 20 01 CALL BRA CALL2
C102 02 VN FCB 2 VERSION NUMBER
C103 10BE CC14 CALL2 LDY LINBUF POINT TO NEXT BUFFER CHARACTER
C107 A6 A4 LDA ,Y GET FIRST CHAR
C109 81 0D CMPA #8D IS IT A CR?
C10B 26 08 BNE SPEC1
C10D B6 CC0C LDA WKDRV GET WORKING DRIVE NUMBER
C110 B7 C843 STA FCBDRV STORE IN FCB
C113 20 15 BRA CALL3
C115 81 30 SPEC1 CMPA #10 IS FIRST CHAR A '0'?
C117 27 0C BEQ SPEC2
C119 81 31 CMPA #11 IS CHAR A '1'?
C11B 27 08 BEQ SPEC2
C11D 86 15 LDA #21 FORCE ILLEGAL FILE SPECS ERROR
C11F B7 C841 STA ERLOC STORE IN FCB
C122 16 00C8 LBRA ERROR
C125 80 30 SPEC2 SUBA #830 CONVERT ASCII TO BINARY
C127 B7 C843 STA FCBDRV STORE DRIVE NUMBER IN FCB
C12A 8E C840 CALL3 LDY #FCB POINT TO FCB
C12D 86 10 LDA #16 OPEN SYSTEM INFO RECORD
C12F A7 84 STA ,X STORE IN FCB
C131 BD D406 JSR FMS CALL FMS
C134 1026 00B5 LBNE ERROR CHECK FOR ERRORS
C138 8E 0007 LDY #7 GET RECORD CODE
C13B A7 84 STA ,X STORE IN FCB
C13D BD D406 JSR FMS CALL FMS
C140 1026 00A9 LBNE ERROR CHECK FOR ERRORS

C144 8E C23E LDY #STRNAM POINT TO STORAGE AREA
C147 C6 80 LDB #128
C149 6F 80 CALL4 CLR ,X+ CLEAR STORAGE
C14B 5A DECB
C14C 26 FB BNE CALL4

C14E 8E C1F6 LDY #CURNMS CURRENT NAME STRING
C151 BD CD1E JSR PSTRNG PRINT IT
C154 8E C890 LDY #FCB+80 POINT TO VOLUME NAME
C157 C6 0B LDB #11 PREPARE TO OUTPUT 11 CHAR
C159 A6 80 LOOP1 LDA ,X+ LOAD DATA, BUMP ADDRESS
C15B BD CD18 JSR PUTCHR OUTPUT NEXT CHARACTER
C15E 5A DECB
C15F 26 F8 BNE LOOP1 PRINT UNTIL DONE
C161 8E C208 LDY #NEWNMS NEW NAME STRING
C164 BD CD1E JSR PSTRNG PRINT IT

```

```

C167 BD CD1B JSR INBUF INITIATE BUFFER INPUT
C16A 8E C23E LDY #STRNAM POINT TO STORAGE AREA
C16D BD CD27 LOOP2 JSR NXTCH GET NEXT BUFFER CHARACTER
C170 25 04 BCS FILL1 EXIT ON NON-ALPHA CHAR

C172 A7 80 STA ,X+ STORE IN WORK AREA
C174 20 F7 BRA LOOP2 TRANSFER UNTIL DONE
C176 8C C23E FILL1 CMPX #STRNAM WAS FIRST CHAR NON-ALPHA (CR)?

C179 27 20 BEQ NUMBER IF SO, SKIP TO DISK NUMBER
C17B 86 FF LDA #8FF
C17D A7 84 STA ,X FLAG END OF NAME
C17F 8E C23E LDY #STRNAM POINT TO INPUT NAME
C182 108E C890 LDY #FCB+80 POINT TO NAME IN FCB
C186 C6 0B LDB #11
C188 A6 80 FILL2 LDA ,X+ GET CHAR FROM INPUT NAME
C18A 81 FF CMPA #8FF END OF NAME?
C18C 27 07 BEQ FILL3 IF SO, PAD WITH NULLS
C18E A7 A0 STA ,Y+ ELSE, TRANSFER TO FCB
C190 5A DECB
C191 26 F5 BNE FILL2 TRANSFER UNTIL FLAG REACHED

C193 20 06 BRA NUMBER NO PADDING NEEDED
C195 4F FILL3 CLRA
C196 A7 A0 STA ,Y+ STORE NULLS IN FCB
C198 5A DECB
C199 26 FA BNE FILL3 PAD UNTIL DONE

C19B 8E C21A NUMBER LDY #CURNMB CURRENT NUMBER STRING
C19E BD CD1E JSR PSTRNG PRINT IT
C1A1 8E C89B LDY #FCB+91 POINT TO VOLUME NUMBER
C1A4 5F CLRB SUPPRESS PADDING
C1A5 BD CD39 JSR OUTDEC OUTPUT DECIMAL NUMBER
C1A8 8E C22C LDY #NEWNMB NEW NUMBER STRING
C1AB BD CD1E JSR PSTRNG PRINT IT
C1AE BD CD1B JSR INBUF GET LINE FROM INPUT BUFFER
C1B1 10BE CC14 LDY LINBUF POINT TO FIRST CHARACTER
C1B5 BD CD48 JSR INDEC INPUT DECIMAL NUMBER
C1B8 25 1C BCS WRITE EXIT ON NON-NUMERIC CHARACTER

C1BA 5D TSTB
C1BB 27 19 BEQ WRITE EXIT ON INVALID NUMBER
C1BD 5F CLRB
C1BE A6 A0 NUMB2 LDA ,Y+ GET NEXT DIGIT
C1C0 81 0D CMPA #8D IS IT A CR?
C1C2 27 03 BEQ NUMB3 EXIT IF SO
C1C4 5C INCB
C1C5 20 F7 BRA NUMB2 GET DIGITS UNTIL CR REACHED
C1C7 C1 04 NUMB3 CMPB #4
C1C9 22 0B BHI WRITE ACCEPT IT IF LESS THAN 10000

C1CB 108E C89B LDY #FCB+91 POINT TO VOLUME NUMBER
C1CF 4F CLRA
C1D0 A7 A4 STA ,Y CLEAR OUT NUMBER BYTES
C1D2 A7 21 STA 1,Y
C1D4 AF A4 STX ,Y STORE VOLUME NUMBER IN FCB
C1D6 8E C840 WRITE LDY #FCB POINT TO FCB
C1D9 6F 88 1E CLR 30,X TRACK NUMBER IN FCB
C1DC 86 03 LDA #3 SECTOR NUMBER
C1DE A7 88 1F STA 31,X STORE IN FCB
C1E1 86 0A LDA #10 WRITE ONE SECTOR
C1E3 A7 84 STA ,X STORE IN FCB

C1E5 BD D406 JSR FMS CALL FMS
C1E8 26 03 BNE ERROR CHECK FOR ERRORS
C1EA 7E C003 JMP WARMS RETURN TO FLEX

C1ED BD CD3F ERROR JSR RPTERR REPORT ERROR
C1F0 BD D403 JSR FMSCLS CLOSE FMS
C1F3 7E C003 JMP WARMS RETURN TO FLEX

* STRING EQUATES

C1F6 43 55 52 52 CURNMS FCC 'CURRENT NAME = ',804
C208 4E 45 57 20 NEWNMS FCC 'NEW NAME? ',804
C21A 43 55 52 52 CURNMB FCC 'CURRENT NUMBER = ',804
C22C 4E 45 57 20 NEWNMB FCC 'NEW NUMBER? ',804

* NAME STORAGE AREA

C23E STRNAM RMB 128

END CALL

```



Listing 2: Mill Example (Assembly)

```

DEMO PROGRAM FOR THE MILL

* McMill Demo
* Feb 25, 1983
* From Programming the 6809
* Modified for relative addressing

                                ORG   $7FFE
7FFE 0000                        FCB   $00,$00
8000 308D0028 BUBBLE LEAX  BASE,PCR GET TABLE
8004 C62C                        LDB   #LENGTH
8006 5A                          DECB
8007 3085                        LEAX  B,X    Point to end
8009 6F8D001E CLR    EXCHG,PCR Clear exchange flag
800D A684 NEXT LDA    ,X    A=Current entry
800F A182 CMPA   ,-X    Compare with next
8011 2C0E BGE    NOSWIT Go to Noswit if curr.&=next
8013 3404 PSHS  B      Save B
8015 E684 LDB   ,X    Get next
8017 E701 STB   1,X    Store in current
8019 A784 STA   ,X    Store current in next
801B 3504 PULS  B      Restore B
801D 6C8D000A INC   EXCHG,PCR Set exchange flag
8021 5A NEXT NOSWIT DECB Decrement B
8022 26E9 BNE   NEXT Continue until 0
8024 6D8D0003 TST  EXCHG,PCR Exchanged=0?
8028 26D6 BNE   BUBBLE Restart if not 0
802A 39 RTS
802B EXCHG RMB 1
      BASE EQU *
802C 1A LENGTH FCB 26
802D 4744525548 FCC "GDRUHBSEQIGNVC"
8033 4253455149474E56
803B 43
803B 4B4654554F FCC "KFTUOPLFDSQC"
8041 504C4644535143

```

Listing 3: 68000 Example (Assembly)

```

68000 ASSEMBLY LANGUAGE PROGRAM : STRING SEARCH

002000: 207C00002040 1 ORG $2000
002006: 227C00002053 2 MOVEA.L #MAIN,A0 ;LOW RANGE LIMIT
00200C: 7003 3 MOVEA.L #TEST,A1 ;HIGH RANGE LIMIT
002012: 48A7000A 4 MOVE.L #3,D0 ;TEST STRING LENGTH
002018: 48E70900 5 MOVEM D1/D3,-(SP) ;SAVE REGISTERS
00201E: 48E70900 6 MOVEM.L A0/A3,-(SP) ;ON STACK
7 *
8 * SEARCH FOR FIRST CHAR OF TEST STRING
9 *
002016: 1611 10 MOVE.B (A1),D3 ;FIRST TEST CHAR
002018: 95CA 11 FIRST SUBA.L A2,A2 ;CLEAR A2 TO START
00201A: 0C10002A 12 CHKEND CMPI.B #'*',(A0) ;END OF MAIN?
00201E: 671E 13 BEQ.S RETRN ;YES. GO EXIT
002020: B618 14 CMP.B (A0)+,D3 ;FIRST CHAR MATCH?
002022: 66F6 15 BNE.S CHKEND ;NO. KEEP SEARCHING
16 *
17 * FIRST TEST CHAR FOUND, COMPARE REST
18 *
002024: 3200 19 MOVE D0,D1 ;STORE TEST LENGTH
002026: 5541 20 SUBQ #2,D1 ;D1=COUNT-2
002028: 2649 21 MOVEA.L A1,A3 ;STORE TEST ADDR.
00202A: 528B 22 ADDQ.L #1,A3 ;LOOK AT CHAR TWO
00202C: 2448 23 MOVEA.L A0,A2 ;STORE MAIN ADDR.
00202E: 538A 24 SUBQ.L #1,A2
002030: 0C10002A 25 LOOP CMPI.B #'*',(A0) ;END OF MAIN?
002034: 6708 26 BEQ.S RETRN ;IF SO, RETURN
002036: B10B 27 CMPM.B (A3)+,(A0)+ ;COMPARE CHARS
002038: 66DE 28 BNE.S FIRST ;MATCH FAILED
00203A: 51C9FFF4 29 DBF D1,LOOP ;KEEP COMPARING
00203E: 4E4F 30 RETRN TRAP #15 ;DUMP REGS, EXIT
002040: 57415348494E 31 MAIN ASC 'WASHINGTON BULLETS*'
002053: 544F4E 32 TEST ASC 'TON'

```

Listing 4: 68000 Example (BASIC)

```

APPLESOFT PROGRAM : UPLOADS MACHINE LANGUAGE PROGRAM
ONTO 68000 BOARD AND EXECUTES IT.

10 A = PEEK (49280): CALL - 936
20 PRINT CHR$(4);"BLOAD UTIL2,A$8600,D1"
:CALL 38383
30 PRINT CHR$(4);"BLOAD SEARCH.OBJ0,D2,A$6000"
40 P = 38383:Q = P - 102: CALL 38380
50 CALL Q: REM 07 002000 6008 0056
60 CALL Q: REM 02 002000
70 CALL P - 27
80 PRINT
:PRINT "IF THE TEST STRING WAS FOUND, REGISTER"
90 PRINT "A2 WILL BE 00 00 20 47."
100 PRINT
:PRINT "IF THE TEST STRING WAS NOT FOUND,"
110 PRINT "REGISTER A2 WILL BE 00 00 00 00120 END

```





## Transition Period

Commodore's product line has evolved quickly over the 4½ years since the first PETs were delivered. The heart of the PET is the 6502 microprocessor, designed by Commodore's [then] newly acquired subsidiary, MOS Technology. At that time the company's only computer product was the small-keyboard PET, long since phased out in favor of models with full-sized business and graphics keyboards. From these evolved an 80-column model, which later gave rise

to the 96K CBM 8096 and the SuperPET. With the exception of the SuperPET (or the 6809 half of it), all are essentially the same computer.

Then Commodore introduced the VIC-20, billed as the "first full-featured computer for under \$300." It was named after its technological centerpiece, an inexpensive CRT controller called VIC (Video Interface Chip). Many things about the VIC-20 are radically different. Some are obvious compromises to obtain a low price: the keyboard has fewer keys and no numeric keypad; the screen consists of only 23 rows of 22 characters; only 5K

of RAM is included; a separate TV or monitor is required; the IEEE-488 bus is gone; and no cassette player is included. There are many improvements aimed particularly at the home market (as opposed to the hobbyist market of the PET): color, sound, a controller port, programmable function keys, and program cartridge capability. The VIC, even with all its differences, is easily identifiable as a descendant of the PET. The operating system is essentially the same as the PET and CBM; PET/CBM BASIC programs run on a VIC with relatively few adjustments; and the processor is still a 6502.

# Commodore New Wave

*by Loren Wright*

## — Commodore 64 — First in New Wave

At the same time that Commodore was gearing up for a massive VIC-20 advertising campaign last fall, it introduced the Commodore 64. The Commodore 64 looks very much like the VIC-20 (it even appears that the same mold was used for the case), but the inside is a lot different. Featured are four new chips: the 6510 microprocessor, the 6526 CIA interface chip, the 6581 SID sound chip, and 6567 VIC II video chip.

The 6510 is a 6502 with an added I/O port, which is used to switch RAM, ROM, and I/O in and out of the 64K address space. There is actually 64K of RAM in there that could be used all at once, if you wanted to design your own operating system. The practical advantage is that things like the character

generator and I/O chips can share the same address space and get switched in only when needed. Under the BASIC operating system provided, this means that about 8K more RAM is available for program storage. As in the VIC, the most fundamental tasks, such as getting a character from the keyboard and putting a character on the screen, are concentrated in a single 4K ROM called the KERNAL. This design feature, combined with the built-in switching, makes the C64 ideal for such languages as Pascal and FORTH, which have much of their own operating systems built in. When the BASIC ROMs permanently occupy address space as they do in the PET, these languages use additional space, leaving less for programs, or operate from the disk, making operation slow. With the C64, the BASIC ROMs can be switched out and RAM (or cartridge ROM) can be switched into the same space.

The VIC II is a considerable improvement over the VIC. It allows 25 rows of 40 characters, fine scrolling, high-resolution graphics, and eight hardware-maintained movable object blocks (called sprites). With the relative abundance of RAM, high-resolution graphics and user-defined character sets are more practical than they are with the limited memory of the VIC-20. For detailed information on the capabilities of the VIC II chip, see my December 1982 PET Vet column (MICRO 55:54).

The SID is an extremely powerful sound chip with four different waveforms, envelope generators, filters, ring modulation, and synchronization for each of three voices. See my February 1983 PET Vet column (MICRO 57:71) for more on the synthesizer-like capabilities of the SID chip.

The CIA adds a time-of-day clock to the familiar 6522 VIA. Two of them are



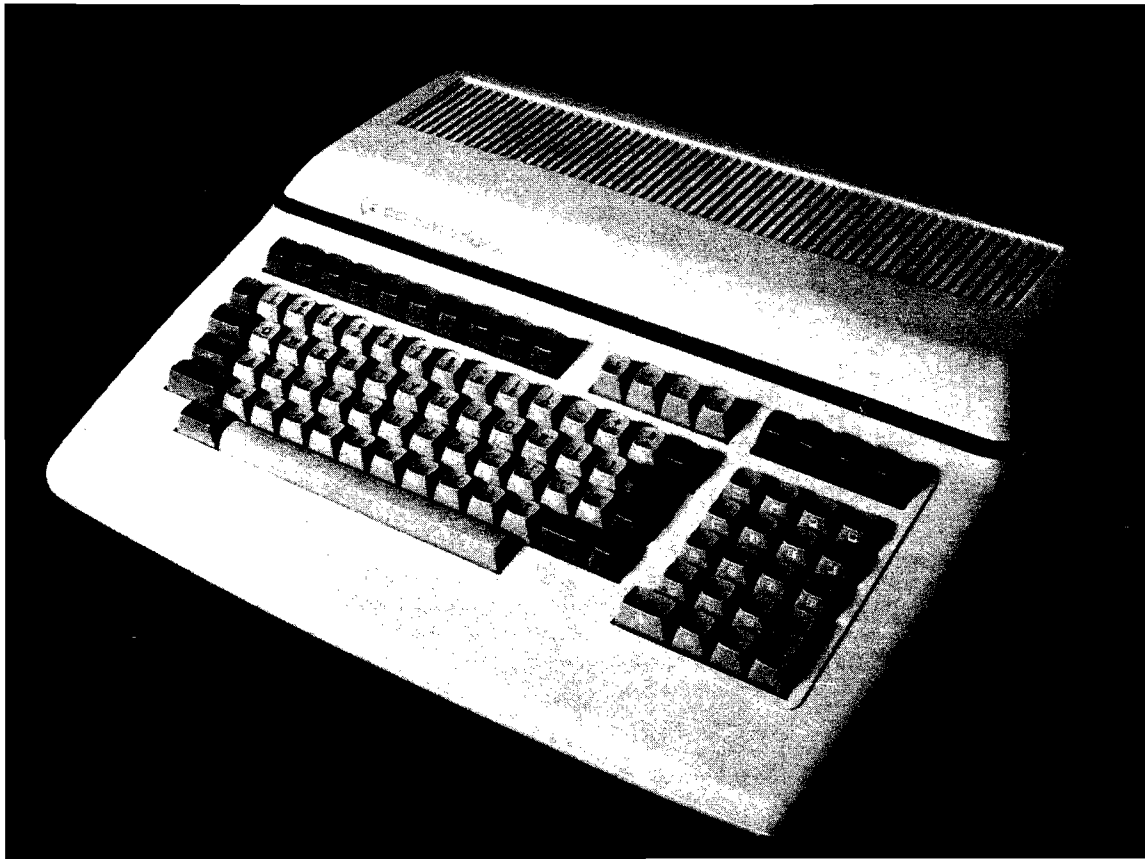

Commodore's C 128/80

used in the C64 — one for the keyboard and one for the parallel user port.

The C64 apparently will give rise to a whole line of portable computers designed to compete favorably with the Osborne portable computers. The unit is smaller than the Osborne, and it will be available in three different models: 1. a 5-inch black and white monitor and single 5¼-inch floppy drive, 2. a 5-inch color monitor and single floppy drive, and 3. a color monitor and dual floppy drive. The third will sell for less than \$1700; the others less.

This line was previewed in prototype versions at the Consumer Electronics Show in Las Vegas in January. The machines are apparently a C64 complete with 6510, SID, VIC II, and CIA's, but in a different configuration. Further details were unavailable from Commodore, and there is no telling exactly when these machines will appear in stores.

### 6509 Addresses 1 Megabyte

Three new models, all based on another new processor (the 6509) were announced last year. They have received various names (500 and 700 series; PET II and CMB II; B, P, and BX series), but now it seems that only one,

the C 128/80, will appear soon.

Like the C64 and VIC-20, the keyboard and computer are combined in a single low-profile unit. When this unit is connected to a black and white monitor, it produces an 80-column display of 9x14 characters. Both business and PET-graphics character sets are included. The keyboard is expanded considerably. There is a separate numeric keyboard with double-zero, 'clear-entry', and double-size 'enter' keys. There is a row of 10 programmable function keys across the top of the main keyboard. The cursor controls are on four separate keys, rather than only two. Also, unlike the VIC and the C64, the unit includes a switching power supply and 'whisper' fan.

As its name implies, the C 128/80 includes 128K of RAM, and that is expandable internally to 256K and externally to 896K. This is accomplished with the new 6509 microprocessor, which performs its own bank switching to address this much memory. The instruction set is identical to that of the 6502.

The BASIC supplied in 24K of ROM is a further advancement beyond BASIC 4.0 (5.0?). Apparently programs written in BASIC 4.0 will run under the new BASIC.

The C 128/80 has a number of different interfaces. The IEEE-488 inter-

face makes it possible to use any Commodore peripheral, including floppy and hard disk drives and several printers. The IEEE-488 bus is also used by Hewlett-Packard, Tektronix, and Fluke in many of their scientific instruments. The RS-232C interface, accomplished with a 6551 ACIA chip, makes a great number of peripherals available including auto-answer/auto-dial modems and inexpensive printers. Also available is the parallel user port supported by the 6526 CIA chip.

The 6581 sound chip, with all the sound capabilities, is also included.

### Breakers on the Horizon

Commodore's Max machine (or Ultimax?) has not appeared yet, perhaps because of the current success of the VIC-20. Also, I presume there will be machines in the same line as the C 128/80, only with different features (a color monitor, included disk drives?).

Commodore showed a prototype of a hand-held computer, but sources indicate that product won't see the light of day.

*You may contact Loren Wright at P.O. Box 6502, Amherst, NH 03031.*



# IS 16-BITS THE SOLUTION ?

by Keith Roberson

---

**Sixteen-bit microprocessors have made a significant impact on the imagination of microcomputer users, for a good reason. But it's just possible that for the novice small business user the distinction is moot, if not actually irrelevant. This article discusses why 8-bit technology, while far from the leading edge, can be expected to have a long and active life in the small computer marketplace.**

---

The 8-bit microprocessor has come a long way since its inception; from a hobbyist's toy to the foundation of the burgeoning business computer marketplace. The introduction of a new microprocessor generation — the high performance 16-bit systems — marks another step toward maturity. This event has moved some industry observers to see in it an abrupt end to the product life of the eight-bit business computer system.

The new computers do, in fact, have certain advantages over the older technology. Faster and more powerful than their 8-bit predecessors, they are already making 8-bit technology obsolete.

Or are they?

Ask a potential small business computer buyer for an opinion on the subject. Chances are he won't know what you're talking about — or care.

And why should he?

Most microcomputer business systems buyers are technologically uninformed. Many prefer to keep it

that way. Trend-setters in their own right, they accept the microcomputer as a potentially useful tool for solving their business and information management problems. Accountants, clerical workers, executives, or professionals, few have used anything more complex than an adding machine or a hand-held calculator before. They want economical, efficient, and productive solutions to their business problems. The details of a technology that achieves this could hardly interest them less.

They must deal with many factors and are confronted by an incredible number of factors in making a choice among business computers for their own applications.

Asking them to choose between 8-bit and 16-bit microprocessor technology is to add to the complexity of an already enormously confusing mass of variables. Since any such decision in the last analysis must be based on the harsh realities of business, the objective of the selection process is to

choose the computer that does the best job in the specific installation, at the lowest cost.

The issue of 8-bit *versus* 16-bit business computers must be secondary to this concern. Nevertheless, the 16-bit computer system is drawing vast amounts of attention to itself. To an uninformed observer, the claims carry a measure of validity. Some discussion of these claims, and a comparison of eight-bit and 16-bit systems may help clarify the issues for prospective business computer buyers.

## **Bits, Bytes, and MIPS**

Sixteen-bit systems are often described as high performance machines. That there are major differences between 8- and 16-bit microprocessors cannot be disputed. However, that does not mean 16-bit technology is the fix-all-problems solution to business microcomputer problems. Many factors can affect overall system performance, and the most ad-

# COMPU SENSE

## VIC-20®

VIC-20®	<b>Personal Computer</b>	\$169.95
VIC-1515	<b>Printer</b>	334.95
VIC-1530	<b>Datasette</b>	67.50
VIC-1541	<b>Disk Drive</b>	375.00
VIC-1010	<b>Expansion Module</b>	139.95
VIC-1311	<b>Joystick</b>	9.95
VIC-1312	<b>Game Paddles</b>	19.95
VIC-1600	<b>Telephone Modem</b>	99.95
VIC-1210	<b>VIC 3K Memory Expander Cartridge</b>	34.95
Plugs directly into the VIC's expansion port. Expands to 8K RAM total.		
VIC-1110	<b>VIC 8K Memory Expander Cartridge</b>	52.50
8K RAM expansion cartridge plugs directly into the VIC.		
CM101	<b>VIC 16K Memory Expander Cartridge</b>	99.95
CM102	<b>24K Memory Expander Cartridge</b>	119.95
VIC-1011A	<b>RS232C Terminal Interface</b>	39.95
Provides interface between the VIC-20 and RS232C telecommunications modems. Connects to VIC's user port.		

**PETSPPEED** - Basic Compiler for Commodore 130.00  
 Compile any Pet Basic program. The only optimizing compiler. Programs compiled with Petspeed run up to 40 times faster. Petspeed code is unstable and compiled programs cannot be tampered with. No security device required for compiled programs. Available NOW for the Commodore 64.

<b>Star Gemini 10 Printer</b>	Call for price
<b>Star Gemini 15 Printer</b>	Call for price
<b>SMD Monitor</b>	Call for price

**CARDBOARD 6** \$87.95  
 An expansion interface for the VIC-20. Allows expansion to 40K or accepts up to six games. May be daisy chained for more versatility.

**CARDBOARD 3** \$39.95  
 Economy expansion interface for the VIC-20.

**CARD "Z" CARD/PRINT** \$79.95  
 Universal Centronics Parallel Printer Interface for the VIC-20 or CBM-64. Use an Epson MX-80 or OKIDATA or TANDY or just about any other.

**CARDETTE** \$39.95  
 Use any standard cassette player/recorder with your VIC-20 or CBM-64.

**LIGHT PEN** \$29.95  
 A light pen with six good programs to use with your VIC-20 or CBM-64.

## HOME & BUSINESS PROGRAMS For VIC-20 & C-64

CW-107A	<b>Home Calculation Program Pack</b>	\$48.95
CPV-31	<b>Data Files</b> - your storage is unlimited	14.95
CPV-96	<b>Household Finance Package</b> - to keep records of all your household expenses	30.95
CPV-208	<b>Bar-Chart</b> - display your numerical data	8.95
CH	<b>Turtle Graphics</b> - learn programming	34.95
CH	<b>VIC Forth</b> - is a powerful language for BASIC programming	49.95
CH	<b>HES MON</b> - is a 6502 machine language monitor with a mini-assembler	34.95
CH	<b>HES Writer</b> - time-saving word processing tool	34.95
CH	<b>Encoder</b> - keep your personal records away from prying eyes	34.95
CT-21	<b>Statistics Sadistics</b> - statistical analysis	14.95
CT-121	<b>Total Time Manager 2.0</b> - creates personal or business schedules	15.95
CT-124	<b>Toll Label</b> - a mailing list and label program	13.95
CT-125	<b>Toll Text BASIC</b>	15.95
CT-126	<b>Research Assistant</b> - keep track of reference data	17.50
CT-140	<b>Toll Text Enhanced</b>	29.95
CM-152	<b>Grafix Designer</b> - design graphic characters	12.95
CQ-5	<b>Minimon</b> - allows you to program, load, save, or execute machine language programs	13.95
CT-3	<b>Order Tracker</b>	15.95
CT-4	<b>Business Inventory</b> - to maintain record of inventory	15.95
CS	<b>Home Inventory</b> - lists your home belongings	17.95
CS	<b>Check Minder</b> - (V-20 & 64) keep your checkbook the right way	14.95
CS	<b>General Ledger</b> - a complete general ledger	19.95
CHC-504	<b>HES Writer</b> - word processor	39.95
CHC-503	<b>Turtle Graphics II</b> - utilizes the full graphics of your 64	49.95
CHC-502	<b>HESMON</b> - machine language monitor w/mini-assembler	34.95
CHP-102	<b>6502 Professional Development System</b>	29.95
CF	<b>Data Files</b> - a management program	27.95
CPV-327	<b>HESCOM</b> - transfers data and programs bidirectionally between VICs at three times the speed of a disk drive	40.95
CPV-328	<b>HESCOUNT</b> - monitors program execution	19.95
CHV	<b>HESPLOT</b> - Hi-res graphics subroutines	12.95
CPV-367	<b>Conversions</b> - figures, volume, length, weight, area, and velocity to all possible configurations	7.95
CC	<b>The Mail</b> - your complete mail program	Cassette 24.95 Disk 29.95
CPV-220	<b>Client Tickler</b>	16.95
CPV-221	<b>Club Lister</b>	13.95
CPV-224	<b>Depreciator</b>	9.95
CPV-236	<b>Investment Analyst</b> - keep track of investments and investment opportunities	12.95
CPV-251	<b>Present Value</b>	10.95
CPV-269	<b>Super Broker</b>	12.95
CPV-270	<b>Syndicator</b> - calculates whether to buy or sell	13.95
CPV-274	<b>Ticker Tape</b> - maintains investments profile	14.95
CPV-276	<b>Un-Word Processor</b> - screen editor	16.95
CPV-286	<b>Phone Directory</b> - never lose a phone number again	9.95
CS-111	<b>Checkbook</b> - home "utility" program	14.95
CPV-294	<b>Calendar My Appointments</b> - print a calendar for every month in any year.	14.95
CPV-296	<b>The Budgeter</b> - place your personal finances in order	12.95

CS1

**QUICK BROWN FOX**  
 The Word Processor of this decade!

\$60.50

## COMMODORE SOFTWARE

VIC-1211A	<b>VIC-20 Super Expander</b>	\$57.99
Everything Commodore could pack into one cartridge - 3K RAM memory expansion, high resolution graphics plotting, color, paint and sound commands. Graphic, text, multicolor and music modes. 1024x1024 dot screen plotting. All commands may be typed as new BASIC commands or accessed by hitting one of the VIC's special function keys. Includes tutorial instruction book. Excellent for all programming levels.		
VIC-1212	<b>Programmer's Aid Cartridge</b>	\$45.99
More than 20 new BASIC commands help new and experienced programmers renumber, trace and edit BASIC programs. Trace any program line-by-line as it executes, pause to edit. Special KEY command lets programmers redefine function keys as BASIC commands, subroutines or new commands.		
VIC-1213	<b>VICMON Machine Language Monitor</b>	\$48.99
Helps machine code programmers write fast, efficient 6502 assembly language programs. Includes one line assembler/disassembler.		

## NEW GAMES FOR YOUR VIC-20®

CC58	<b>Astroblitz</b> - This game is challenging, even to a VIC-MASTER! Navigate your ship carefully to avoid being hit by enemy fire.	\$39.95
CC60	<b>Terraguard</b> - Speed and careful skill will enable you to once again destroy the aliens. Too slow? You're destroyed by their beam.	39.95
CC98	<b>Serpentine</b> - This game will test your patience & skill. Object - to survive long enough to lay eggs and raise your young	39.95
CC500	<b>Intruder-Scrambler</b> - In your bomber, invade the defending scramble system, dodging rockets, to blow up enemy posts, etc.	19.95
CC101	<b>Choplifter</b> - Rescue the American hostages & return them safely to the U.S. You will encounter tanks, jets and killer satellites.	39.95
CC102	<b>Black Hole</b> - Your mission is, simply, to survive! Your ship must not be hit by space objects or sucked into the Black Hole!	39.95
CC104	<b>Apple Panic</b> - Speed is required! Destroy the apple monsters by digging holes in the brick floors for them to fall into	39.95
CC65	<b>Video Mania</b> - Introducing your enemies. EVIL EYE, WALWOKER, KILLERBOX. Your only defense - throw your alien zapper!	39.95
CS1	<b>Flags of Nations</b> - A game that challenges players to identify flags of various widely-known nations of the world.	10.95
CS2	<b>Flags of Nations - Second Edition</b> - A field of 34 flags of lesser known nations of the world	10.95
CS3	<b>Cities and States</b> - A game that draws a map of a state or states and asks players to name key cities in those states.	10.95
CS4	<b>Cities of the World</b> - Deals with important cities of nations throughout the world.	10.95
CS5	<b>Mountains and Rivers</b> - Draws large geographical area maps. You identify major mountain ranges, rivers & bodies of water	10.95

## NEW GAMES FOR YOUR C-64

<b>Tank Arcade</b> (Also for VIC-20) - Pre-determine how many hits it will take to wipe out your opponent. Then, on with the battle! Battlefield changes	\$13.95
<b>Roadracer</b> - Choose the type of track & a time or lap race. Use steady control at speeds of 50 to 200 miles per hour. Hit the wall & lose valuable time	13.95
<b>Shootout at the OK Galaxy</b> (Also for VIC-20) - 30 alien warships have entered your war zone. Shields up? Energy level OK? Defend yourself.	19.95
<b>Galaxy</b> - Have you ever wanted to conquer the universe? Send your galactic fleets out to explore, solar system by solar system. From 1 to 20 players.	19.95
<b>Bomber Attack</b> - Ground to air warfare. You're in command of a supersonic bomber over enemy terrain. Drop all 25 bombs on key locations.	14.95
<b>Midway Campaign</b> - Your computer controls a huge force of Japanese ships trying to conquer Midway Island. Your only advantage is surprise.	19.95
<b>Dnieper River Line</b> - A fictionalized engagement between Russian & German forces in 1943. Soviet forces, controlled by the computer, seek to overrun your line and capture sufficient objectives to attain victory. Four levels of difficulty.	25.00
<b>Tanktics</b> - Armored combat on the Eastern front of WWII. You start outnumbered 2 to 1 but you choose your tank types before the battle.	24.50
<b>Guns of Fort Defiance</b> - You are the commander of a 19th artillery piece in a besieged fort. Choose type of ammo. Set the cannon's elevation, deflection.	20.00
<b>Computer Baseball Strategy</b> - You, the manager of the home team, test your skill against a wily and unpredictable opponent, your computer.	19.95
<b>Lords of Karma</b> - Like an intriguing puzzle! Decipher secrets while exploring a mythical, magical city & countryside. Avoid the lurking monsters!	20.00
<b>North Atlantic Convoy Raider</b> - It's the Bismarck convoy raid of 1941! The computer controls the British ships. Will you change history?	19.95
<b>Planet Miners</b> - Compete against others and the computer to stake valuable mining claims throughout the solar system in the year 2050.	19.95
<b>Conflict 2500</b> - In 2500 AD, earth is threatened by attacking aliens with an infinite # of attack strategies with which to tease the defending player.	19.95
<b>Nukewar</b> - Nuclear confrontation between two hypothetical countries. Defend your country with espionage, bombers, missiles, submarines, etc.	19.95
<b>Computer Acquire</b> - New Second Edition! The object is to become the wealthiest person in this "business" game - hotel acquisitions & mergers.	20.00
<b>Andromeda Conquest</b> - Vast scale space strategy game of galactic colonizing and conquest. Strange life forms & alien technologies - exciting!	19.95
<b>Telengard</b> - Microcomputer Dungeon Adventure game. Time fantasy and role-playing. 50 levels of ever-more complex mazes to explore & survive!	25.00

MORE — MORE — MORE

Prices subject to change.

TO ORDER:

P. O. Box 18765  
 Wichita, KS 67218  
 (316) 263-1095

WRITE  
 FOR  
 FREE  
 CATALOG



Personal checks accepted (Allow 3 weeks)  
 or C.O.D. (Add \$2) Handling charges \$2.00

VIC-20® is a registered trademark of Commodore

Circle No. 23



vanced technology is not always the most appropriate.

Comparisons of the two technologies are usually made on the basis of performance. But software availability, expansion capability, and price are factors a buyer must definitely consider in the process of selecting a high-ticket capital item like a computer that will be used for several years. And performance itself must be viewed within the parameters of realistic settings and the constraints these impose on a system.

## Performance

Perhaps the most widely used — and most misleading — measure of a computer's performance is the number of binary digits (bits) the Central Pro-

cessing Unit (CPU) can access or manipulate at one time. Bits constitute the atoms of a computer. They are processed in clusters (words) of 8, 16, 32, 64, or more at one time. The larger the word, the more information a computer can process in a given time. Hence the concern over word size.

**In these popular configurations, the critical path to high performance is not RAM size but speed of the disk storage unit. This is not at all affected by the CPU, whether it be 8-bit or 16-bit.**

cessing Unit (CPU) can access or manipulate at one time. Bits constitute the atoms of a computer. They are processed in clusters (words) of 8, 16, 32, 64, or more at one time. The larger the word, the more information a computer can process in a given time. Hence the concern over word size.

A 16-bit processor such as the Intel 8086 has twice the word size of Zilog's 8-bit Z80, but that does not mean it has twice the performance. Sixteen-bit microprocessor chips come in many forms and configurations. The Intel 8088, for example, processes a 16-bit word internally, but transfers it via an 8-bit external data path (bus), in order to allow designers of 16-bit systems to incorporate it into existing 8-bit designs. On the other hand, Motorola's 68000 has a 32-bit internal architecture and a 16-bit bus, yet both are considered 16-bit microprocessors.

The performance of these wider bandwidth computers is nearly always limited by their application. The application itself can impose conditions that nullify any performance advantage provided by a state of the art technology. For example, word processing — which accounts for the bulk

## MIPs and Clock Speed

of current small business microcomputer applications — involves the extensive manipulation of alphanumeric data. But alphanumeric data is represented in an 8-bit format. In such an application, the capabilities of a 16-bit microprocessor are grossly underutilized. The buyer ends up paying for excessive unused capability. However, extensive scientific calculations — such as Fourier transforms, for example — could show dramatic increases in through-put by utilizing the wider internal bandwidth of 16-bit processors.

A better performance benchmark than word size, or the number of bits in a system, is the number of instructions or operations a processor can execute in a given amount of time.

The unit of measure generally used is MIPS (million instructions per second). This value is largely dependent on the CPU clock speed. Typically, the new 16-bit processors have clock speeds about 50% faster than 8-bit chips, and have bus widths that in many instances allow them to handle twice as much data at a time.

Faster clock speeds account for most of the perceived performance increases of 16-bit microprocessors over their 8-bit predecessors. The Intel 8086, for example, runs at 6 MHz. Taking into account its word size, and a slightly more powerful instruction set, it could be said to run twice as fast as an 8-bit Z80A running at 4 MHz. However, in many applications the 8086 is comparable in performance to a Z80B running at 6 MHz, and slower than a Z80H running at 8 MHz.

## Internal and External Memory

One of the indisputable advantages of a 16-bit system is its inherent ability to address or access more random ac-

cess memory (RAM or main memory), typically a megabyte or more, compared to the 64-kilobyte limit of the 8-bit chips. However, advances made through a technique called bank switching, allow 8-bit micros to access many times their nominal 64K limit.

A large internal memory makes it possible to design a computer that can use a sophisticated operating system (OS) — a program always resident in RAM that oversees the loading and execution of the application programs. A large RAM also reduces the need for frequent access to the much slower disk memory by keeping larger portions of program and data in the much faster RAM.

But RAM is one of the most expensive parts of a computer system. And a megabyte of internal memory is far in excess of what today's most popular applications programs are designed to use.

Most business application programs available today are disk intensive. That is, they rely heavily on disk media for external memory or data storage. In these popular configurations, the critical path to high performance is not RAM size but speed of the disk storage unit. This is not at all affected by the CPU, whether it be 8-bit or 16-bit.

There are two main types of disks and disk drives: hard and floppy. A hard disk costs about five times as much as a floppy, is orders of magnitude faster, and offers on-line storage accessibility measured in megabytes, as opposed to the kilobytes of storage offered by floppies.

Two other features of fast disks that are not remarkably affected by the use of 16-bit microprocessors are direct memory access (DMA) — which optimizes the transfer time from disk to memory, and buffering, the use of a temporary memory as a holding area to reduce frequent disk access.

## Software

Most often considered a separate issue, software is intimately associated with performance. The finest hardware is useless without strong applications and systems software. What sometimes appears to be a troublesome performance problem is often resolved through the use of redesigned software.

Eight-bit based systems enjoy a distinct advantage here, especially when coupled with Digital Research's CP/M operating system (or a compatible variation of it), the industry's de-



facto operating system. Thousands of CP/M applications exist for 8-bit systems, written and tested over the many years since microcomputers emerged as a valid tool for use in business and other settings. Compared to the few hundred applications presently available for 16-bit machines, the advantage of implementing an 8-bit system is clear, where the objective is to be up and running with the largest selection of application software from which to select suitable programs.

Another factor to consider in evaluating the appropriateness of 16-bit over 8-bit installations, is the fact that the bulk of 16-bit programs are derived from direct analogs of the 8-bit versions and do not really take advantage of the 16-bit's potential for increased performance. While this may not be an important concern for users who plan to develop their own applications programs, it can be a significant consideration for those whose objective is to use the new machine as soon as possible to solve pressing business or professional problems.

Interestingly enough, many of the most talked about recent advances in applications software (such as multi-user and shared data base programs) were developed on 8-bit machines and then ported over to the 16's. This is not quite so strange as it sounds; most 16-bit machine manufacturers still rely on 8-bit computer sales for their bread and butter.

### Expandability and Multi-user Capability

The ability to expand — whether it be the size of internal or external memory, or the number of users it will support — is a frequently over-looked but important measure of performance.

The decision on which system to obtain must be based as much on current needs as on the needs of the predictable future.

What if more users need to access the system? What will happen to system performance if more users are added? Is the current storage capacity adequate? If not, can the storage capacity be expanded? Will it be possible to modify the system readily, or must it be scrapped and another system selected to replace it?

In short, is it a system with a reasonable productive life in the setting where it will be used?

For most serious business computer users, multi-user capability is a must. As a business grows, more ways to use

a computer are soon discovered. Within a surprisingly short time, it becomes evident that a single-user system — be it a 16-bit business computer or an 8-bit personal computer enhanced to its limits to fit into such a setting — is inadequate.

Along with the increased number of applications, the need for easy access to common files and the most recent information also grows.

If anticipated computer usage for the future justifies selecting a system that can easily accommodate additional users and memory expansion, at least two major options are currently available: additional single-user workstations or multi-user systems.

Multi-user systems are available in two architectures: *time sharing* and *distributed processing*.

### Time-Sharing

Time-sharing allows several users to share a single computer apparently simultaneously. The system behaves as if the computer serves only that one user, when, in fact, the user controls only one time slice of many. Time-

necessary functions as memory management, scheduling and device polling.

### Distributed processing

In distributed processing, several microcomputers are linked together to perform like one big computer. users may be added without significant degradation of system performance.

The costs associated with extensive cabling, stand-alone computer installations and their maintenance, must be evaluated against the advantages of this approach. Cost effectiveness is always an important consideration in any decision involving a business.

An interesting compromise to both types of systems has been made by a number of systems that utilize a dual processor architecture. users share 8-and 16-bit processors transparently; indeed, users may run 8-bit and 16-bit on the same system concurrently. This provides the opportunity to use 8-bit software available today, and offers a viable migration path to the 16-bit as more sophisticated software for it becomes available. However, true parallel operation is not generally possible on these systems. Most of

**An easy-to-use 16-bit operating system may be hampered by a lack of software.... Even 16-bit microprocessors show significant degradation sometimes slowing down to unacceptable response rates....**

sharing has its origins in traditional mainframe and minicomputer operations, and is based on the most economical utilization of expensive resources.

A user program takes control of a CPU, does some processing for a while, then gives up the CPU to another user.

The immediate cost advantage of time-sharing is the ability to add more users without significant hardware expenditures. However, performance rapidly deteriorates as more users are added. Even 16-bit microprocessors show significant degradation, sometimes slowing down to unacceptable response rates with the addition of only one or two users.

Additional overhead is also paid in performance and memory space for the operating system to handle such

them use tightly-coupled processors, and, in most cases, only one processor is running at a time. This reduces the cost/benefit factor to the user by providing only very slight performance advantage over a single CPU system.

All things considered, buyers of business computer systems may need to pay more attention to future expansion capability than processing speed when evaluating the performance benefits of 8-bit *versus* 16-bit computers.

### Price Considerations

If price were the only consideration, 8-bit machines would win hands down, since they make up virtually the entire low-priced end of the market. However, price must be coupled with performance; an Apple may be bought

for under \$2000, but could cost twice as much in additional hardware to perform the most simple business functions at reasonable levels. Nor will it ever be able to do the things a true business computer can do. By the same token, an IBM mainframe could do it all, but the cost would not be justified.

Picking a system with the best price performance ratio is a matter of deciding which features are needed and finding the lowest-priced system with those features.

### Other Considerations

Possibly the worst obstacle to more rapid integration of microcomputers into the society can be found in the industry's lack of standardization. Incompatible and untried operating systems abound. Users often are unwittingly obliged to serve as a test site.

Among multiuser systems, some operating systems may be promising at this point of their development. It remains for the individual user to evaluate the benefits of any operating system, whether it be MS/DOS, CP/M86, UNIX, or a UNIX look-alike, running in a 16-bit environment, over a

CP/M, or CP/M compatible, operating system running in an 8-bit environment. Each approach has its benefits, along with its disadvantages. An easy-to-use 16-bit operating system may be hampered by a lack of software. A multiuser MP/M operating system may be forcing the 8-bit microprocessor to function at the extremes of its capability, leaving it vulnerable to malfunctions.

A recently developed approach has been adopted by several manufacturers, who have designed multi-user networked operating systems that are compatible with CP/M. These include MUSE, CP/NET, MMOST, NSTAR and several others.

Given the need for caution in making capital investments, the probability remains that eight-bit operating systems with CP/M capability, will continue to remain the preferred choice of business computer users for some time to come.

### The Solution

Today's small-business computer users are looking for ways to handle their work more efficiently. The 16-bit







systems are appropriate in some applications, but in many more the best choice may depend more on established 8-bit technology.

There is no question that the bigger processors will eventually replace the 8-bit processors. The current lack of 16-bit software, however, and the predictable need to expand capacity, combine to make high performance distributed processing systems a viable alternative while waiting for the microcomputer to mature more fully. Indeed, some industry analysts think that the new 32-bit processors will take over before the 16-bit have a chance to take hold, and most are now in agreement that the 8-bit will still be around for many years to come.

**Z80, Z80A, Z80B, Z80H** are registered trademarks of Zilog. **8086, 8088** are registered trademarks of Intel Corporation. **CP/M** and **MP/M** are registered trademarks of Digital Research Corporation. **UNIX** is a trademark of Bell Laboratories. **Zeus4** is a registered trademark of OSM Corporation.

You may contact Keith Roberson at OSM Computer Corporation, Mountain View, CA.

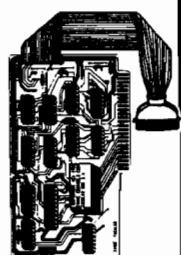
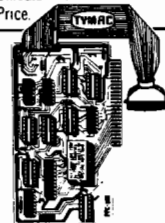
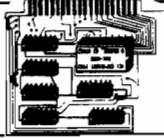
**MICRO**

 <h1 style="display: inline; margin: 0 10px;">HARDWARE</h1> 		 <h1 style="display: inline; margin: 0 10px;">SOFTWARE</h1> 	
<h3>THE TACKLER™ — DUAL • MODE PARALLEL INTERFACE FOR THE APPLE® 2 BOARDS IN ONE FOR NO MORE COMPATIBILITY PROBLEMS!</h3> <p>An intelligent board to provide easy control of your printer's full potential. Plus a standard parallel board at the flip of a switch — your assurance of compatibility with essentially all software for the APPLE®. Hires printing with simple keyboard commands that replace hard to use software routines. No disks to load. Special features include inverse, doubled, and rotated graphics and many text control features, available through easy keyboard or software commands. Uses industry standard graphics commands. This is the first truly universal intelligent parallel interface! Change printers — no need to buy another board. Just plug in one of our ROM'S and you're all set. ROM'S available for Epson, C. Itoh, NEC, and Okidata — others available soon. Specify printer when ordering. Call for Price.</p> 		<h3>Super Pix</h3> <p>Hires screendump software for the Epson, OKI, C. Itoh and Nec 8023. Use with Tymac PPC-100. Special <b>\$19.95</b> (Specify Printer)</p>	
<h3>THE UPGRADEABLE PPC-100 PARALLEL PRINTER CARD</h3> <p>A Universal Centronics type parallel printer board complete with cable and connector. This unique board allows you to turn on and off the high bit so that you can access additional features in many printers. Easily upgradeable to a fully intelligent printer board with graphics and text dumps. Use with EPSON, C. ITOH, ANADEX, STAR-WRITER, NEC, OKI and others with standard Centronics configuration. <b>\$139.00</b></p> 		<h3>Mr. Lister — Customer Contact Profiler &amp; Mailer</h3> <p>A Super Mail List Plus more — up to 1000 Entries on single 3.3 Disk (only 1 Drive required) — 2 second access time to any name — full sort capabilities — Dual Index Modes — supports new 9 digit Zip. Easy to follow manual — Not Copy Protected — 4 user defined tables with 26 sort selections per table — Beta tested for 6 months — user defined label generation. Introductory Price \$135. <b>\$99.00</b> Dealer &amp; Dist. Inquiries Invited.</p>	
<h3>IF YOU WANT GRAPHICS AND FORMATTING THEN CHOOSE THE PERFORMER</h3> <p>for Epson, OKI, NEC 8023, C. ITOH 8510 provides resident HIRES screen dump and print formatting in firmware. Plugs into Apple slot and easy access to all printer fonts through menu with PR# command. Use with standard printer cards to add intelligence. <b>\$49.00</b> specify printer.</p> 		<h3>APPLE LINK</h3> <p>A communications system for the Apple® (Requires Hayes Micro Modem). Transmit and receive any type of file between APPLES®, Automatic multi-file transfer, real time clock indicating file transfer time. Complete error check. Plus conversation mode. Only one package needed for full transfers. Compatible with all DOS file types. (requires Hayes Micro Modem) <b>\$59.00</b></p>	
<h3>THE MIRROR FIRMWARE FOR NOVATION APPLE CAT II®</h3> <p>The Data Communication Handler ROM Emulates syntax of an other popular Apple Modem product with improvements. Plugs directly on Apple CAT II Board. Supports Videx and Smarterm 80 column cards, touch tone and rotary dial, remote terminal, voice toggle, easy printer access and much more. List <b>\$39.00</b> Introductory Price <b>\$29.00</b></p>		<h3>THE APPLE CARD/ATARI CARD</h3> <p>Two sided 100% plastic reference card Loaded with information of interest to all Apple and Atari owners. <b>\$3.98</b></p>	
<h3>MINI ROM BOARDS</h3> <p>Place your 2K program on our Mini Rom Board. Room for one 2716 EPROM. Use in any slot but zero. Only <b>\$34.95</b></p>		<h3>NIBBLES AWAY II</h3> <p><b>AGAIN! Ahead of all others.</b></p> <ul style="list-style-type: none"> <li>• <b>AUTO-LOAD PARAMETERS</b> . . . Free's the user from having to Manually Key in Param values used with the more popular software packages available for the Apple II.</li> <li>• <b>EXPANDED USER MANUAL</b> . . . incorporates new Tutorials for all levels of expertise; Beginners Flowchart for 'where do I begin' to 'Advanced Disk Analysis' is included.</li> <li>• <b>TRACK/SECTOR EDITOR</b> . . . An all new Track/Sector Editor, including the following features: Read, Write, Insert, Delete Search, and impressive Print capabilities!</li> <li>• <b>DISK DIAGNOSTICS</b> . . . Checks such things as: Drive Speed, Diskette Media Reliability, and Erasing Diskettes.</li> <li>• <b>HIGHEST RATED</b> . . . Best back up Program in Softalk Poll (Rated 8.25 out of 10).</li> <li>• <b>CONTINUAL UPDATES</b> . . . Available from Computer Applications and new listings on the source. <b>\$69.95</b></li> </ul>	
<h3>DOUBLE DOS Plus</h3> <p>A piggy-back board that plugs into the disk-controller card so that you can switch select between DOS 3.2 and DOS 3.3 DOUBLE DOS Plus requires APPLE DOS ROMS. <b>\$39.00</b></p>		<p>Dealer and Distributor Inquiries Invited.</p>  <h2 style="margin: 0;">MICRO-WARE DIST. INC.</h2> <p>P.O. BOX 113 POMPTON PLAINS, N.J. 07444</p> <h1 style="margin: 0;">201-838-9027</h1>	
Circle No. 24			

## Alspa Computer, Inc.

The price-performance leader. Includes Z80A, 1 or 2 full 8" drives (double density, double sided), 3 serial and 1 parallel port, and winchester port. Prices start at less than \$2000. DEALER and OEM inquiries invited.

### SPECIALS on INTRIGATED CIRCUITS

6502	7.45	10/ 6.95	50/ 6.55	100/ 6.15
6502A/6512A	8.40	10/ 7.95	50/ 7.35	100/ 6.90
6520 PIA	5.15	10/ 4.90	50/ 4.45	100/ 4.15
6522 VIA	6.45	10/ 6.10	50/ 5.75	100/ 5.45
6532	7.90	10/ 7.40	50/ 7.00	100/ 6.60
2114-L200	2.45	25/ 2.30	100/ 2.15	
2716 EPROM	4.90	5/ 4.50	10/ 4.00	
2532 EPROM	7.90	5/ 7.45	10/ 6.90	
6116 2KX8 CMOS RAM	7.90	5/ 7.45	10/ 6.90	
4116 RAM		8 for 14		
Zero Insertion Force 24 pin Socket (Scanbe)				2.00

## Hewlett Packard



Write or call for prices.

### Anchor Automation Signalman Modems

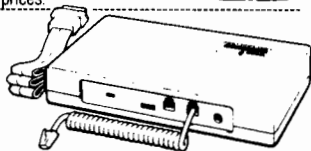

### FREE SOURCE MEMBERSHIP WITH SIGNALMAN

All Signalman Modems are Direct Connect, and include cables to connect to your computer and to the telephone. Signalman Modems provide the best price-performance values, and start at less than \$100. Dealer and OEM inquiries invited

Mark I RS232	(99)	79
Mark II for Atari 850	(99)	79
Mark IV for CBM/PET with software	(169)	119
Mark V for Osborne (software available)	(129)	93
Mark VI for IBM Personal Computer	(279)	195
Mark VII Auto Dial/Auto Answer	(179)	119
Mark VIII Bell 212 Auto Dial/Answer	(399)	319

DC HAYES Smartmodem	219
DC Hayes Smartmodem 1200	545



Apple Emulator for Commodore 64	89
Screenmaker 80 COLUMN CARD for C64	155
Solid Oak 2 Level Stand for C64 or VIC	29
C64/VIC Switch (networking)	135
BACKUP V1.0 tape copier for C64 or VIC	20
CARDBOARD/6 Motherboard - VIC	79
CARDAPTER/1 Atari VCS Adapter - VIC	69
CARDPRINT Printer Interface - C64/VIC	64
CARDBOARD/3s Motherboard - VIC	32
CARDETTE/1 Cassette Interface - C64/VIC	32
CARDRITER Lightpen - C64/VIC	32
CARDRAM/16 RAM Expansion - VIC	64

### We carry Apple II+ from Bell & Howell

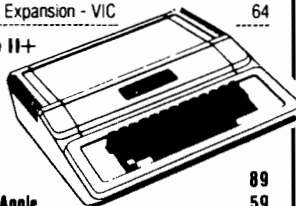

Apple Emulator for Commodore 64	89
16K RAM Card for Apple	59
Solid Oak 2 Level Stand for Apple	29
Super Serial Card	149
Thunderclock Plus	119
Z80 Softcard and CP/M (Microsoft)	235
Parallel Printer Interface/Cable	79
Apple Dumping (Microtek) Printer Interface	115
Apple Dumping with 16K Buffer	160
Grappler + Interface	140
TG Products for Apple in stock	
DC Hayes Micromodem II	299
Videx 80 Column Card	239
Hayden Software for Apple 20% OFF	
PIE Writer Word Processor	120

## Commodore

See us for Personal, Business, and Educational requirements. Educational Discounts available.

### PETSCAN \$245 base price

Allows you to connect up to 30 CBM/PET Computers to shared disk drives and printers. Completely transparent to the user. Perfect for schools or multiple word processing configurations. Base configuration supports 2 computers. Additional computer hookups \$100 each.

### Commodore COMMUNICATES!

### COMPACT \$115

Intelligent Terminal Package includes: ACIA hardware based interface; DB25 Cable and STCP Software with remote telemetry, transfer to/from disk, printer output, XON-XOFF control, user program control, status line.

### VE-2 IEEE to Parallel Interface 110

Includes case, power supply, full 8-bit transmission, and switch selectable character conversion to ASCII

VIC 20 Products	VIC Sargon II Chess	32
BACKUP V1.0	VIC GOLF	32
VIC RAM Cards in stock	Meteor Run (UMI)	39
VIC SuperExpander	VIC Radar Racetrack	24
VIC 16K RAM	Amok (UMI)	20
Thorn EMI Software	Snakman	15
HES Software	Rubik's Cube	13
VIC Omega Race	Programmers Reference	15
Spiders of Mars (UMI)	Renaissance (UMI)	39
Programmers Aid	VIC Adventure Series	
VICTORY Software for VIC and C64		
Street Sweepers	Maze in 3-D	12
Night Rider	Cosmic Debris	12
Treasures of Bat Cave	Grave Robbers Advent.	11
Games Pack I	Games Pack II	12
Victory Casino	Adventure Pack I	12
Adventure Pack II	Trek	11

Commodore 64 Programmers Reference Guide	17
Compute's First Book of PET/CBM	11
POWER ROM Utilities for PET/CBM	78
WordPro 3+ - 32K CBM, disk, printer	195
WordPro 3+/64	69
WordPro 4+ - 8032, disk, printer	300
SPELLMASTER spelling checker for WordPro	170
VISICALC for PET, ATARI, or Apple	190
PETRIX PET to Epson Graphics Software	40
SM-KIT enhanced PET/CBM ROM Utilities	35
Programmers Toolkit - PET ROM Utilities	35
Branding Iron EPROM Programmer for CBM	75
PET Spacemaker II ROM Switch	36
2 Meter PET to IEEE or IEEE to IEEE Cable	40
Dust Cover for PET, CBM, 4040, or 8050	8
VIC or C64 Parallel Printer Interface	64
CmC IEEE-RS232 Printer Interface - PET	120
SADI Intelligent IEEE-RS232 or parallel	235
ZRAM - CBM 64K RAM, Z80, CP/M	550
Programming the PET/CBM (Compute!) - R. West	20
Compute! First Book of VIC	11
Whole PET Catalog (Midnight Gazette)	8
Color Chart Video Board for PET	125
PET Fun and Games (Cursor)	11
Disk ICU—Disk Recovery System for PET/CBM	40
Copy-Writer Word Processor for C64, PET/CBM	70

### FlexFile for PET CBM, C64 \$110

Database, Report Writer with Calculations, Mailing Lists

FORTH for PET full FIG model - Cargill/Riley	\$50
Metacompiler for FORTH for independent object code	30
KMMM PASCAL for PET/CBM/C64	85
EARL for PET/CBM Disk-based ASSEMBLER	65
Super Graphics - BASIC Language Exercises	45
Fast machine language graphics routines for PET/CBM	
RAM/ROM for PET/CBM	4K \$75 8K \$90

## DISK SPECIALS



Scotch (3M) 5" ss/dd	10/ 2.25	50/ 2.10	100/ 2.05
Scotch (3M) 5" ds/dd	10/ 3.15	50/ 2.90	100/ 2.85
Scotch (3M) 8" ss/dd	10/ 2.40	50/ 2.20	100/ 2.15
Scotch (3M) 8" ds/dd	10/ 2.95	50/ 2.70	100/ 2.65

### We stock VERBATIM DISKS

Write for Dealer and OEM prices.

BASF 5" or 8"	10/ 2.00	20/ 1.95	100/ 1.85
NEW BASF Qualimetric Disks also in stock			
Wabash 5" ss/sd	10/ 1.80	50/ 1.75	100/ 1.70
Wabash 5" ds/sd	10/ 2.00	50/ 1.95	100/ 1.90
Wabash 8" ss/sd	10/ 2.00	50/ 1.95	100/ 1.90

### We stock MAXELL DISKS

Write for dealer and OEM prices.

Disk Storage Pages	10 for \$5	Hub Rings 50 for \$6
Disk Library Cases	8"—3.00	5"—2.25
Head Cleaning Kits	11	

### CASSETTES—AGFA PE-611 PREMIUM

High output, low noise, 5 screw housings.			
C-10	10/ .61	50/ .58	100/ .50
C-30	10/ .85	50/ .82	100/ .70

## SPECIALS

Zenith ZVM-121 Green Phosphor Monitor	100
BMC 12A 12" Green Monitor	80
VOTRAX Personal Speech System	280
VOTRAX Type-N-Talk	160
VOICE BOX Speech Synthesizer (Apple or Atari)	
Prowriter 8510 parallel	389
Okidata 92	520
Daisywriter 2000	1050
Many printers available (Star-Gemini, Brother, OKI, etc.)	
We Stock AMDEK Monitors	
Amdek DXY-100 Plotter	600
A P Products	15% OFF
Watanabe Intelligent Plotter 990	6-pen 1290
ISOBAR 4 Outlet Surge Suppressor/Noise Filter	49
We stock Electrohome Monitors	
dBASE II (8" format)	300
Panasonic TR-120M1P 12" Monitor (20 MHz)	149
Panasonic CT-160 Dual Mode Color Monitor	285

### USI Video Monitors—Green or AMBER 20 MHz hi-res. Dealer and OEM inquiries invited

### ALL BOOK and SOFTWARE PRICES DISCOUNTED

Synertek SYM-1 Microcomputer	SALE 189
KTM-2/80 Synertek Video and Keyboard	349

## ZENITH data systems

Z29 Terminal (new detached keyboard)	680
ZT-1 Intelligent Communications Terminal with Monitor	479
Z100 16-bit/8-bit System	CALL
We stock entire Zenith line.	

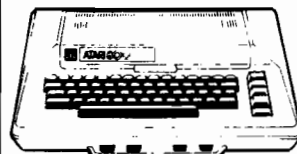

## ATARI SPECIALS

### WE STOCK ENTIRE LINE—write for prices.

Atari 1200	749	QIX	Atari 39
Voice Box	100	Anchor Modem—Atari	74
Inside Atari DOS	18	Atari Graphics (Computer)	11
Thorn EMI Software		First Book of Atari	11
EduFun Software		APX Software	

### WRITE FOR CATALOG

Add \$1.25 per order for shipping. We pay balance of UPS surface charges on all prepaid orders. Prices listed are on cash discount basis. Regular prices slightly higher. Prices subject to change.

252 Bethlehem Pike Colmar, PA 18915 215-822-7727 **A B Computers**

# GET MORE DATA ON YOUR CBM DISK

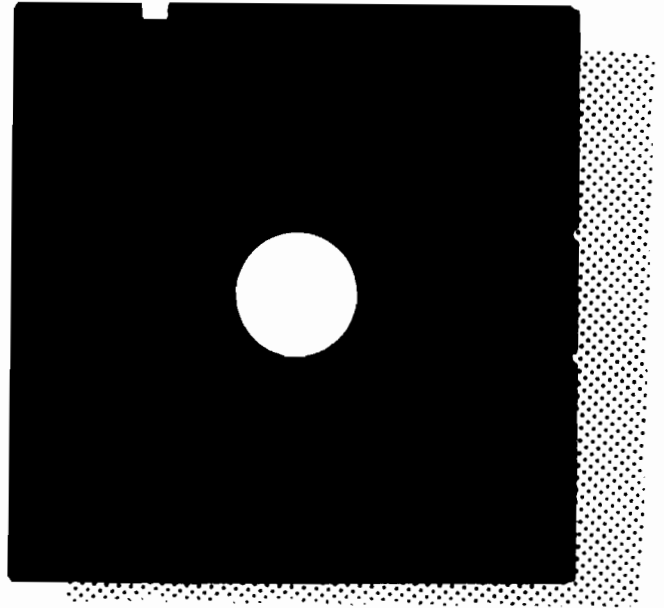

by Werner Kolbe

---

**The Commodore operating systems write numerical data to disk as ASCII strings. This article shows you how to write up to four times more numerical data on the CBM disk using the computer's internal binary format instead of ASCII strings.**

---

The data sheet for your floppy disk system tells you how many bytes you can store on a disk, but normally it does not tell you how effectively the system uses the space to store your data. In the case of the PET/CBM disks up to four times more data can be stored when a compressed format is used for storing numbers.

I use my Commodore PET in conjunction with a 4040 floppy disk system to store huge amounts of statistical data upon dogs' tooth failures. These data are mostly integers and only a few are large enough to require floating-point format. I noticed that these data, after they were written on the disk, needed more bytes than they had used in my computer. The reason is simple: the data files on disk or tape are represented in ASCII format, whereas in the computer they are stored more compactly. Storing the data in a compressed form is not less reliable than storing it in the ASCII code. In both cases you will get a wrong number (or read error) if the wrong byte is read from disk.

The operating system of the PET treats all external devices in the same manner, and so it sends data to the disk in the same format as it sends data to the printer, which is the ASCII format. Thus, an integer that can be repre-

sented by two bytes may need as many as eight bytes. You could save three-quarters of the space by writing the data in the same compressed format on the disk as it is stored in the computer.

The simplest and fastest way to store compressed data is to assign the value of the number that will be stored on disk to a special variable and then PEEK the storage area of that variable. The BASIC interpreter allocates storage area to the simple variables (not arrays) in the sequence of their occurrence behind the BASIC program, and so it is a good idea to use the special variable as the first variable of your program. This variable will then be located directly behind the BASIC program and can be PEEKed easily, using the contents of RAM locations 42, 43 that point to the beginning of the variable list.

The same principle is used to read the data back. Using GET, you read the appropriate number of bytes from the disk, then POKE the number into the storage area of the special variable. The latter will return the value of the number.

Listing 1, Compress Example 1, shows you how this method works if you want to store integers on the disk. The special variable is called XX%, but it will work with other names as well. The % identifier must be there to en-

sure that its content is represented by only two bytes. The variable YY points to the first of these two bytes, which you must send to the disk to write a number. To read it back into the computer POKE the ASCII values of the characters received from the disk into the storage area of the dummy variable XX%. The example writes two files on the disk to demonstrate the difference in the space needed for the same numbers. Then the compressed numbers are read back into the computer to complete the process.

Listing 2, Compress Example 2, shows how the compression can be done for floating-point variables. The only difference is that now the special variable must be of the floating-point type and that five bytes are used to represent a number. This time the space used on the disk is about three times less.

Finally, listing 3 shows how you can write both compressed integers and floating-point numbers within the same program. This time the variable XX is second in the list and you get the location of its storage area by adding 7 to the pointer YY%.

The example programs will run on all ROMs of the PET/CBM, VIC, and Commodore 64 computers. I do not know how other personal computers store numbers on disk, but if it is done in ASCII then a similar procedure could be used to increase the available space on disk.

---

You may contact Werner Kolbe at Vd Kamlaan 65, 2625 Kn Delft, Netherlands.



## LISTING 1

```

100 REM EXAMPLE HOW TO COMPRESS INTEGERS
110 REM -----
120 REM
130 REM TWO SAMPLE FILES ARE WRITTEN.
140 REM ONE IN STANDARD ASCII FORMAT
150 REM AND ANOTHER IN COMPRESSED FORMAT.
160 REM THE COMPRESSED VERSION NEEDS ABOUT
170 REM FOUR TIMES LESS SPACE ON THE DISK
180 REM
190 REM XX% IS THE DUMMY VARIABLE
200 REM WHICH MUST BE THE FIRST VARIABLE
210 REM IN THE PROGRAM.
220 REM
230 REM YY POINTS TO THE PLACE WHERE
240 REM THE VALUE OF XX% IS STORED IN
250 REM INTERNAL COMPRESSED FORMAT.
260 REM
270 XX%=0
280 YY=PEEK(42)+256*PEEK(43)+2
290 REM
300 REM
310 OPEN1,8,3,"@1:STANDARD,S,W"
320 OPEN2,8,4,"@1:COMPRESSED,S,W"
330 REM
340 A=15E3
350 REM
360 REM WRITE 1000 NUMBERS
370 REM
380 FORI=ATOR+1E3
390 REM
400 REM 1. USING THE STANDARD METHOD
410 REM
420 PRINT#1,I;CHR$(13);
430 REM

```

```

440 REM 2. IN COMPRESSED FORMAT
450 REM
460 REM ASSIGN IT TO THE DUMMY VARIABLE
470 XX%=I
480 REM
490 REM AND WRITE PETS INTERNAL REPRESENTATION
500 REM AS CHARACTERS ONTO THE DISK
510 REM
520 FORJ=0TO1:PRINT#2,CHR$(PEEK(YY+J));:NEXTJ
530 NEXT I
540 CLOSE1:CLOSE2
550 REM
560 REM
570 REM HERE I SHOW HOW TO READ BACK
580 REM THE COMPRESSED DATA.
590 REM
600 OPEN2,8,4,"1:COMPRESSED,S,R"
610 REM
620 REM WE GET A PAIR OF TWO CHARACTERS
630 REM AND POKE IT INTO THE STORAGE
640 REM AREA OF XX%.
650 REM
660 FORJ=0TO1
670 GET#2,A$:IFA$=""THENA$=CHR$(@)
680 POKE(YY+J),ASC(A$)
690 NEXTJ
700 REM
710 REM XX% NOW CONTAINS THE NUMBER
720 REM WHICH WE CAN USE.
730 REM
740 PRINTXX%;:IFST=0THEN660
750 CLOSE2
READY.

```

## COMPRESS

requires:

PET, CBM, VIC, or  
Commodore 64 and a  
Commodore disk drive.

## LISTING 2

```

100 REM EXAMPLE HOW TO COMPRESS FLOATING
110 REM POINT NUMBERS.
120 REM
130 REM
140 REM XX IS THE DUMMY VARIABLE
150 REM
160 REM AGAIN WE WRITE 1000 NUMBERS
170 REM IN STANDARD AND IN COMPRESSED
180 REM FORMAT ONTO THE DISK
190 REM
200 REM
210 XX=0:YY=PEEK(42)+256*PEEK(43)+2
220 OPEN1,8,3,"@1:STANDARD,S,W"
230 OPEN2,8,4,"@1:COMPRESSED,S,W"
240 FORI=1TO1000
250 A=RND(1)/100
260 PRINT#1,A;CHR$(13);
270 XX=A
280 FORJ=0TO4:PRINT#2,CHR$(PEEK(YY+J));:NEXTJ
290 NEXT I
300 CLOSE1:CLOSE2
310 REM
320 REM AND HOW TO READ IT BACK
330 REM
340 OPEN2,8,4,"1:COMPRESSED,S,R"
350 FORJ=0TO4
360 GET#2,A$:IFA$=""THENA$=CHR$(@)
370 POKE(YY+J),ASC(A$)
380 NEXTJ
390 K=XX:PRINTK;:IFST=0THEN350
400 CLOSE2
READY.

```

## LISTING 3

```

100 REM EXAMPLE HOW TO COMPRESS BOTH
110 REM INTEGERS AND FLOATING POINT
120 REM NUMBERS.
130 REM
140 REM XX% AND XX ARE DUMMY VARIABLES
150 REM
160 REM YY% AND YY ARE THE POINTERS TO
170 REM THEIR STORAGE AREA.
180 REM
190 XX%=0:XX=0
200 YY%=PEEK(42)+256*PEEK(43)+2
210 YY=YY%+7
220 REM XX IS THE SECOND VARIABLE
230 REM
240 OPEN2,8,4,"@1:MIXTURE,S,W"
250 FORI=1TO100
260 A=I+RND(1)
270 REM WRITE IN PAIRS I,A
280 REM FIRST I AS COMPRESSED INTEGER
290 REM
300 XX%=I:FORJ=0TO1:A$=CHR$(PEEK(YY%+J)):PRINT#2,A$;:NEXT
310 REM
320 REM AND THEN A
330 XX=A:FORJ=0TO4:PRINT#2,CHR$(PEEK(YY+J));:NEXTJ
340 NEXT I
350 CLOSE1:CLOSE2
360 REM
370 REM AND HOW TO READ IT BACK
380 REM
390 OPEN2,8,4,"1:MIXTURE,S,R"
391 REM
392 REM FIRST THE INTEGER
393 REM
400 FORJ=0TO1
410 GET#2,A$:IFA$=""THENA$=CHR$(@)
420 POKE(YY%+J),ASC(A$)
430 NEXTJ
440 I=XX%
441 REM
442 REM AND THEN THE FLOATING POINT
443 REM
450 FORJ=0TO4
460 GET#2,A$:IFA$=""THENA$=CHR$(@)
470 POKE(YY+J),ASC(A$)
480 NEXTJ
490 A=XX:PRINTI,A;:IFST=0THEN400
500 CLOSE2
READY.

```

MICRO™

# Parameter Passing in Assembly Language

## Part I

---

**A discussion of several methods of passing data to and from assembly-language subroutines. 6502, 6809, 68000, and 16032 microprocessors are used for programming examples.**

---

*by Randall Hyde*

**P**rogramming in assembly language has long been thought a black art accomplished only by skilled magicians and sorcerers. An assembly-language program requires many more statements to accomplish the same goal than does the equivalent Pascal or BASIC program. Because of the extra tedium involved, most people shy away from assembly language because there is too much to learn. In reality, anyone with enough patience can master assembly language easily. One of the major impediments to learning assembly language is learning to pass data to and from assembly-language subroutines. This article discusses various methods of passing data on the 6502, 6809, and the newer 6800 and 16032 microprocessors.

### **Passing Data in the Microprocessor Registers**

The simplest method used to pass data to and from an assembly-language

subroutine is *via* the processor registers. Any register capable of storing retrievable data is usable for passing data to and from an assembly-language subroutine. On the 6502 data can be passed in the accumulator, X register, Y register, and the processor status register. On the 6809 data can be passed in the A or B accumulator, the X or Y index register, or the U stack pointer register. On the 16032 data can be passed in any of the eight general purpose registers, the static base register, or the frame pointer. Of the four microprocessors described here, the 68000 provides the richest complement of processor registers. Eight general purpose and seven address registers are available to the programmer in addition to the 68000 stack pointer.

The 6502 A, X, and Y registers are eight bits wide, and so you are limited to transferring a single byte within one of the registers. Single-bit boolean/binary values can be passed in the carry, zero, minus, and overflow flags.

Such variables can be tested easily using the 6502 branch instructions.

The 6809 A and B accumulators are both eight bits wide and can be used for passing 8-bit data to and from a 6809 subroutine. If you need to transfer 16 bits of data, the A and B accumulators can be concatenated to form a single 16-bit accumulator — the 6809 D accumulator. Sixteen-bit data also can be passed in the 6809 X, Y, and U registers. Single-bit data can be passed in the 6809 zero, carry, overflow, and negative flags. Thirty-two-bit data can be passed by passing the low order 16 bits in one register and the high order 16 bits in a second register.

The 16032 microprocessor from National Semiconductor is far more advanced than its 8-bit brothers, the 6502 and 6809. Almost all of the 16032 registers are 32 bits wide, allowing you to pass a considerable amount of data in a single register. Furthermore, there are eight general purpose registers, three special purpose registers, and the pro-

cessor status register available for use. Since a considerable amount of data can be passed using the 16032 registers, passing parameters in the registers is much more practical on the 16032 than on the 6502 or 6809.

When it comes to passing data in the processor registers, the 68000 wins hands down. With 15 32-bit undedicated registers and a 32-bit stack pointer, the 68000 provides more registers than any popular micro-processor currently on the market.

Deciding when data is to be passed in one of the processor registers is the only problem left to solve. Since registers are a scarce commodity, judicious use of the register resources is recommended. Suppose you need to pass three bytes of data to a 6502 subroutine. Since you have three registers available, it would seem natural to pass the parameters in the A, X, and Y registers. In most cases such a choice would be very poor because these registers may be required for calculations going on outside the subroutine being called. For example, assume you are passing three bytes of data to a 6502 subroutine in the A, X, and Y registers. Furthermore, suppose you wish to call this subroutine repeatedly (i.e., from within a loop). The 6502 X and Y index registers are perfect for controlling loops and variables external to some subroutine. Unfortunately the X and Y registers will not be available for such use if they must be used for passing parameters to a subroutine, especially since you cannot push the X or Y register onto the stack without disturbing the contents of the accumulator. For this reason the use of the 6502 X and Y registers for passing parameters should be avoided as much as possible.

The 6809's register set is much more capable of handling parameters passed in the register than is the 6502. First, the 6809 has more registers than the 6502; second, the registers are twice as wide as the corresponding 6502 registers. Nevertheless, you should avoid passing parameters in the X, Y, and U registers for the same reasons outlined in the preceding paragraph.

The NS16032, with its eight general purpose registers, removes many of the restrictions on passing parameters in registers. Still, the frame pointer and Static Base register shouldn't be used

for passing data to and from subroutines. That leaves the eight general purpose 16032 registers. These registers (called R0...R7) are each 32 bits wide, and so the 16032 is capable of passing over ten times the data in the CPU registers that the 6502 can! There's only one problem with using the 16032's general purpose registers to pass parameters: they *are* general purpose. This means that any of the eight registers can be used as accumulators, pointers, counters, or index registers. On the 6502 and 6809 the X and Y registers are special purpose index, pointer, or counter registers. Therefore, as you are writing a program, you know what the intended purpose of these registers is. Caution must be exercised with the 16032 because any of the registers can be used as an index register.

The 68000's register set provides so many registers for the programmer to use that many of the comments pertaining to register usage in the previous paragraphs simply don't apply. The 68000 data registers are most advantageously utilized for passing pure data

usually requires a single character written to the system console. The READ CHARACTER subroutine (GETC) usually returns a single character read from the system terminal.

On the 6502 the accumulator is the best choice when data needs to be transferred to or from a subroutine. On the 6809 the A or B accumulator can be used to transfer the data. On the 16032 any of the eight general purpose registers can be used, although R0 (for consistency's sake) should be used.

When additional byte parameters must be passed to a subroutine, additional registers must be consumed. On the 6502 the Y register should be used first (because the X index register is used for counting more frequently than the Y register), and the X register last. The 6809 has two 8-bit accumulators that can be used for passing 8-bit parameters. Once these are exhausted you should use the Y register, followed by the X register, followed by the U stack pointer. Remember, the X, Y, and U registers are all 16 bits wide so two bytes can be passed in these registers by packing and unpacking the data. Pack-

---

**When additional byte parameters must be passed to a subroutine additional registers must be consumed. On the 6502 the Y register should be used first...the X register last.**

---

(since most of the arithmetic and logical operations work best with the data registers) and the 68000 address registers should be used for passing pointer data since these registers are best suited for address manipulation.

Once you understand the disadvantages of passing data in the processor registers (i.e., there are only so many of them and they may not always be available for parameter usage) the next step is to decide when and how data is to be passed in the processor registers. The most obvious candidate is a routine that requires a single byte to be passed to it or returns a single byte upon completion. A good example is the READ CHARACTER and WRITE CHARACTER routines found in most monitors and operating systems. The WRITE CHARACTER subroutine (PUTC)

ing two bytes into one of these registers is accomplished easily by loading the A and B accumulators with 8-bit data and then transferring the 16-bit D accumulator to one of the index registers. Of course there may be a more direct way, such as loading the 16-bit register with an immediate value or loading from some 16-bit memory location.

The 68000 and 16032 provide so many general purpose registers that there is little chance of running out of them. On these processors you can simply use additional registers to pass the extra parameter bytes. Although the 68000 and 16032 sport a complete set of 32-bit registers, packing and unpacking the data to preserve space is inefficient; there are better methods for passing parameters.

When you need to pass 16-bit values

to or from a subroutine, the 6502's limitations quickly become apparent. The 6502's registers are all eight bits wide, so you must use two registers to pass a 16-bit value. Most contemporary programs pass the low order eight bits in the Y register and the high order eight bits in the accumulator. Sometimes it would be more convenient to pass the low order byte in the accumulator (because arithmetic and logical operations take place in the accumulator and the low order byte is always operated on first), but my experience has proven that consistency (even with other people's code) is more important than convenience. If you need to pass more than one 16-bit value on the 6502, you will have to resort to another technique for parameter passing as the 6502 has only three bytes of register storage.

Passing 16-bit data on the 6809 is much simpler than on the 6502. The 6809 features a full set of 16-bit data and index registers. To pass a single 16-bit datum, your best bet is to use the

registers]. On the 68000 or the 16032 you should use registers to pass parameters only if you are passing less than five parameters. If you must exceed these limits, then you should use one of the other methods described in this article.

### Passing Parameters in a Fixed Location

Once your register list is exhausted, one of the easiest ways to pass data is by placing it in some fixed memory location before calling the appropriate subroutine. This method is quite popular with several monitor programs such as the Apple monitor and the Atari operating system (PEEKs and POKEs to BASIC hackers). By using this method of data transfer a virtually unlimited number of parameters can be passed. All you need to do is load up the appropriate memory locations and call the subroutine.

There are two principle disadvantages to this method of parameter

Certain global values (such as the horizontal and vertical positions for the cursor in a video screen driver) are perfect for this type of parameter transfer since all code in the system can have immediate and easy access to the data. This method of parameter passing is also perfect for quick and dirty programs where the extra time and thought required to pass data in some other manner is too excessive to be justified (this is especially true on the 6502, which is rather poor with respect to parameter handling).

### Passing the Address of a Parameter Block

One of the major problems with passing parameters in a fixed location is that you must move the data into the fixed location before calling the subroutine. In many applications (like calling a disk operating system OPEN command, or a similar routine) a considerable amount of data needs to be passed to the subroutine, but the parameter values remain static over the lifetime of a program. In these situations it is more efficient to pass the address of a parameter block instead of moving the parameters to some fixed location. One way to accomplish this is to pass the address of the parameter block in one or more of the CPU registers. This is how, for example, Apple's DOS expects the address of the IOB (input output block) to be passed to the RWTS subroutine. On the 6502, most people pass the low order byte of the address of the parameter block in the Y register and the high order byte in the accumulator. On the 6809 one of the index registers (probably the X index register) is the best choice for the job. On the 16032 any of the eight general purpose registers are fine for this type of parameter transfer.

Depending upon the circumstances, the above form of parameter addressing is quite useful if you have a set of stock parameter blocks you wish to pass to a subroutine. For instance, the RWTS example mentioned earlier could benefit from this type of parameter transfer. In your program you define several IOBs and switch between them simply by loading the address of the new IOB.

*Example:*

```
LDY #IOB1 ;GET IOB-LO  
LDA #IOB1 ;GET IOB-HI
```

*(Continued on next page)*

---

## One of the major problems with passing parameters in a fixed location is that you must move the data into the fixed location before calling the subroutine.

---

6809 D accumulator (which is a concatenation of the A and B 8-bit accumulators). If you need to pass two 16-bit values, the D accumulator and Y index registers are your best bet. The Y register should be used in place of the X register because most 6809 programmers use the X register more often than the Y register (this is a carry-over from the 68000 days). If more than three words of data need to be transferred you should choose a method other than using registers to transfer the parameters.

The 68000 and 16032 provide quite a few 32-bit registers, so passing 16- or even 32-bit data to a subroutine is no problem. In general, however, no more than four pieces of data should be transferred in the processor registers because these processors support more advanced methods of parameter transfer.

If you are using the 6502 you should try to limit yourself to two bytes of data passed in the 6502 registers (be it two 8-bit values or a single 16-bit value). On the 6809 you should limit yourself to three 8-bit values or two 16-bit values (using A, B, and Y

transfer. First, loading data into a register and then storing it into some memory location requires more code and takes longer to execute than simply loading a CPU register with the parameter. Secondly, if you reserve a memory location for use by a subroutine (parameter or local variable) it cannot be used for anything else unless you are absolutely certain that no conflict will arise. Good programming practices dictate that you do not use such memory locations for anything else, otherwise the code will not be as maintainable as it could be.

One advantage to this method is that all three processors mentioned in this article support some sort of abbreviated addressing (zero page on the 6502, direct page on the 6809, absolute with a short displacement on the 68000 and 16032) that lets you access certain memory locations using a shortened instruction. Furthermore, accessing such absolute memory locations is usually faster than any other method of parameter transfer other than register usage.

# NEW FROM D & N MICRO PRODUCTS, INC.

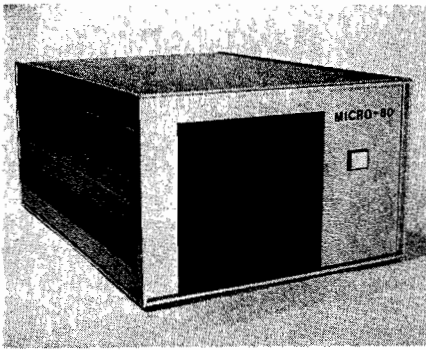

## MICRO-80 COMPUTER

Z80A CPU with 4MHz clock and CP/M 2.2 operating system. 64K of low power static RAM. Calendar real time clock. Centronics type parallel printer interface. Serial interface for terminal communications, dip switch baud rates of 150 to 9600. 4" cooling fan with air intake on back of computer and discharge through ventilation in the bottom. No holes on computer top or side for entry of foreign object. Two 8" single or double sided floppy disk drives. IBM single density 3740 format for 243K of storage on each drive. Using double density with 1K sectors 608K of storage is available on a single sided drive or 1.2 meg on a double sided drive. Satin finish extruded

aluminum with vinyl woodgrain decorative finish. 8 slot backplane for expansion. 48 pin buss is compatible with most OSI boards. Uses all standard IBM format CP/M software.

Model 80-1200	\$2995
2 8" single sided drives, 1.2 meg of storage	
Model 80-2400	\$3495
2 8" double sided drives, 2.4 meg of storage	
Option 001	\$ 95
Serial printer port, dip switch baud rate settings	

### Software available in IBM single density 8" format.

<b>Microsoft</b>		<b>Digital Research</b>		<b>Micropro</b>	
Basic-80	\$289	PL/1-80	\$459	Wordstar	\$299
Basic Compiler	\$329	Mac	\$ 85	Mail-Merge	\$109
Fortran-80	\$410	Sid	\$ 78	Spellstar	\$175
Cobol-80	\$574	Z-Sid	\$ 95	SuperSort I	\$195
Macro-80	\$175	C Basic-2	\$110	<b>Pascal</b>	
Edit-80	\$105	Tex	\$ 90	Pascal/MT +	\$429
Mu Simp/Mu Math	\$224	DeSpool	\$ 50	Pascal Z	\$349
Mu Lisp-80	\$174	<b>Ashton-Tate</b>		Pascal M	\$355
		dBase II	\$595		

### Convert almost any static memory OSI machine to CP/M® with the D & N-80 CPU Board.

Z80A CPU with 4MHz clock. 2716 EPROM with monitor and bootstrap loader. RS-232 serial interface for terminal communications or use as a serial printer interface in a VIDEO system. Disk controller is an Intel 8272 chip to provide single or double density disk format. 243K single density or 608K double density of disk storage on a single sided 8" drive. A double sided drive provides 1.2 meg of storage. DMA used with disk controller to unload CPU during block transfers from the disk drives. Optional Centronics type parallel printer port com-

plete with 10 ft. cable. Optional Real Time Calendar Clock may be set or read using 'CALL' function in high level languages. Power requirements are only 5 volts at 1.4 amps. Available with WORDSTAR for serial terminal systems.

#### INCLUDES CPM 2.2

D & N-80 serial	\$695
D & N-80 serial w/Wordstar	\$870
D & N-80 video	\$695
Option 001	\$ 80
parallel printer and real time calendar clock	

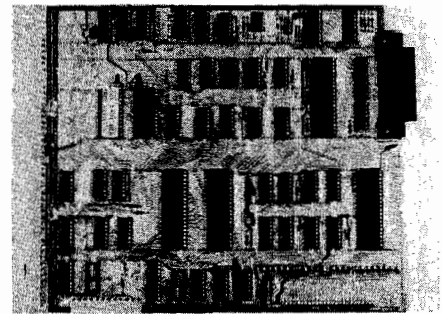

## D & N-80 CPU BOARD

## OTHER OSI COMPATIBLE HARDWARE

**IO-CA10X Serial Printer Port** \$125  
Compatible with OS-65U and OS-65D software

**IO-CA9 Parallel Printer Port** \$175  
Centronics standard parallel printer interface with 10 ft. flat cable

**BP-580 8 Slot Backplane** \$ 47  
Assembled 8 slot backplane for OSI 48 pin buss

**24MEM-CM9** \$380    **24MEM-CM9F** \$530  
**16MEM-CM9** \$300    **16MEM-CM9F** \$450  
**8MEM-CM9** \$210    **8MEM-CM9F** \$360  
**BMEM-CM9F** \$ 50    **FL470** \$180

24K memory/floppy controller card supports up to 24K of 2114 memory chips and an OSI type floppy disk controller. Available fully assembled and tested with 8, 16, or 24K of memory, with floppy controller (F). Controller supports 2 drives. Needs separated clock and data inputs. Available Bare (BMEM-CM9F) or controller only (FL-470). Ideal way to upgrade cassette based system

**C1P-EXP Expansion Interface** \$ 65  
Expansion for C1P 600 or 610 board to the OSI 48 pin buss. Requires one slot in backplane. Use with BP-580 backplane

**BIO-1600 Bare IO card** \$ 50  
Supports 8K of memory, 2 16 bit parallel ports may be used as printer interfaces. 5 RS-232 serial ports, with manual and Molex connectors

**DSK-SW Disk Switch** \$ 29  
Extends life of drive and media. Shuts off minifloppy spindle motor when system is not accessing the drive. Complete KIT and manual

#### Disk Drives and Cables

**8" Shugart SA801** single sided \$395  
**8" Shugart SA851** double sided \$585  
**FLC-66ft.** cable from D & N or OSI controller to 8" disk drive \$ 69

**5 1/4" MPI B51** with cable, power supply and cabinet \$450  
**FLC-5 1/4 8 ft.** cable for connection to 5 1/4 drive and D & N or OSI controller, with data separator and disk switch \$ 75

**Okidata Microline Printers**

**ML 82A Dot Matrix Printer** \$534  
120 CPS, 80/120 columns, 9.5" paper width, friction or pin feed

**ML 83A** Same as 82A except \$895  
16" paper width, 132/232 columns with tractor feed

**ML 84** Same as 82A except 200 CPS, \$1152  
16" paper width, 132/232 columns, 2K buffer, dot addressable graphics, with tractor feed

**D & N Micro Products, Inc.**  
3684 N. Wells St.  
Fort Wayne, Ind. 46808  
(219) 485-6414



TERMS \$2.50 shipping, Foreign orders add 15%.  
Indiana residents add 4% sales tax.

JSR RWTS

LDY #IOB2  
LDA /IOB2  
JSR RWTS

LDY #IOB3  
LDA /IOB3  
JSR RWTS

ETC

IOB1 BYT IOB DATA HERE  
IOB2 BYT IOB DATA HERE  
IOB3 BYT IOB DATA HERE

ETC

If the data in IOB1 differs greatly from the data in IOB2, and both of them differ from the data in IOB3, then this form of parameter transfer is much more efficient than moving the data into an IOB at a fixed memory location. Another advantage to passing this data is the fact that it does not tie up the use of some specific address in the CPU's memory space. All you need to pass is the address of the beginning of the parameter block and, therefore, it can be located anywhere in memory; in fact, it can be relocated at will. Note that any amount of data can be transferred using this technique; the only limitation is that you have enough memory to hold all the parameters. On the 6502 it is best to keep the size of the parameter block below 256 bytes due to the 8-bit limitation of the 6502 index registers. Rarely will a subroutine require more than 30-40 bytes of parameters, so this shouldn't be a problem.

Now that you can pass the address of the parameter to a subroutine, the only problem left is retrieving the actual parameters. While the 16032, 68000, and 6809 microprocessors let you access a data table indirectly through a register, the 6502 does not. To access the parameter data on the 6502 you must store the address into a pair of consecutive zero page memory locations and access the data table using the [ZP],Y or [ZP],X addressing modes. For example, assume that you have a parameter block of the form:

PBLOCK BYT PARM1  
BYT PARM2  
BYT PARM3  
ADR PARM4

and the subroutine has the calling sequence:

LDY #PBLOCK  
LDA /PBLOCK  
JSR SUBROUTN

Inside "SUBROUTN" you would store the accumulator and Y registers into a pair of zero page variables (say PARM-PTR); then you could access the parameters using the [ZP],Y addressing mode as follows:

LDY #0  
LDA (PARMPTR),Y ;Fetches PARM1

LDY #1  
LDA (PARMPTR),Y ;Fetches PARM2

LDY #2  
LDA (PARMPTR),Y ;Fetches PARM3

LDY #3  
LDA (PARMPTR),Y GET PARM4-LO  
INY  
LDA (PARMPTR),Y GET PARM4-HI

On the 6809 accessing the parameter block is much easier. Assuming the address of the parameter block is passed in the X or Y register (it doesn't matter which one) the calling sequence would be:

LDX #PBLOCK Get address of parameter block  
JSR SUBROUTN Call subroutine

To access the data in the parameter block you would use the code:

LDA ,X Access PARM1

LDA 1,X Access PARM2

LDA 2,X Access PARM3

LDD 3,X Access PARM4 (16 bits)

The 68000 calling sequence and parameter access method is almost identical to that for the 6809. The calling sequence is:

MOVE.L #PBLOCK,A0  
JSR SUBROUTN

Within the subroutine you would access data in the parameter block using statements of the form:

MOVE.B 0(A0),D0 ;Copy PARM1 into D0

MOVE.B 1(A0),D1 ;Copy PARM2 into D1

MOVE.B 2(A0),D2 ;Copy PARM3 into D2

MOVE.W 3(A0),D3 ;Copy PARM4 into D3

The 16032 calling sequence and parameter access mechanism is identical to that of the 68000. The calling sequence is:

MOVD #PBLOCK,R7 ;Get address  
; of parameters  
JSR SUBROUTN

Within the subroutine you would access data in the parameter block using statements of the form:

MOVB 0[R7],R0 ;Copy PARM1 into R0

MOVB 1[R7],R0 ;Copy PARM2 into R0

MOVB 2[R7],R0 ;Copy PARM3 into R0

MOVW 3[R7],R0 ;Copy PARM4 into R0

To return data to the calling subroutine simply move the data into the parameter block. Since the calling program presumably knows the address of the parameter block, it can extract data easily from the parameter block after the subroutine returns.

Although the address of the parameter block was passed in the registers in these examples, this address is nothing more than a 16-bit (or 32-bit) parameter, which can be passed to the subroutine in any fashion possible. It could be passed in a register (as we have done here), in a dedicated memory location, or even from within some other parameter block! In fact, any method used for passing 16 or 32 bits of data to a subroutine can be used to pass the address of a parameter block to the subroutine.

(Continued on next page)



BOX 120  
ALLAMUCHY, N.J. 07820  
201-362-6574

**HUDSON DIGITAL ELECTRONICS INC.**

## THE TASK\* MASTERS

HDE supports the \*TIM, AIM, SYM and KIM (TASK) with a growing line of computer programs and peripheral components. All HDE component boards are state-of-the-art 4½" x 6½", with on board regulation of all required voltages, fully compatible with the KIM-4 bus.

### **OMNIDISK 65/8 and 65/5**

Single and dual drive 8" and 5¼" disk systems. Complete, ready to plug in, bootstrap and run. Include HDE's proprietary operating system, FODS (File Oriented Disk System).

### **DM816-M8A**

An 8K static RAM board tested for a minimum of 100 hours and warranted for a full 6 months.

### **DM816-UB1**

A prototyping card with on-board 5V regulator and address selection. You add the application.

### **DM816-P8**

A 4/8K EPROM card for 2708 or 2716 circuits. On board regulation of all required voltages. Supplied without EPROMS.

### **DM816-CC15**

A 15 position motherboard mounted in a 19" RETMA standard card cage, with power supply. KIM, AIM and SYM versions.

### **DISK PROGRAM LIBRARY**

Offers exchange of user contributed routines and programs for HDE Disk Systems. Contact Progressive Computer Software, Inc. for details.

### **HDE DISK BASIC**

A full range disk BASIC for KIM based systems. Includes PRINT USING, IF ... THEN ... ELSE. Sequential and random file access and much more. \$175.00

### **HDE ADVANCED INTERACTIVE DISASSEMBLER (AID)**

Two pass disassembler assigns labels and constructs source files for any object program. Saves multiple files to disk. TIM, AIM, SYM, KIM versions. \$95.00

### **HDE ASSEMBLER**

Advanced, two pass assembler with standard mnemonics. KIM, TIM, SYM and KIM cassette versions. \$75.00 (\$80.00 cassette)

### **HDE TEXT OUTPUT PROCESSING SYSTEM (TOPS)**

A comprehensive text processor with over 30 commands to format and output letters, documents, manuscripts. KIM, TIM and KIM cassette versions. \$135.00 (\$142.50 cassette)

### **HDE DYNAMIC DEBUGGING TOOL (DDT)**

Built in assembler/disassembler with program controlled single step and dynamic breakpoint entry/deletion. TIM, AIM, SYM, KIM AND KIM cassette versions. \$65.00 (\$68.50 cassette)

### **HDE COMPREHENSIVE MEMORY TEST (CMT)**

Eight separate diagnostic routines for both static and dynamic memory. TIM, AIM, SYM, KIM and KIM cassette versions. \$65.00 (\$68.50 cassette)

### **AVAILABLE DIRECT OR FROM THESE FINE DEALERS:**

Progressive Computer Software  
405 Corbin Road  
York, PA 17403  
(717) 845-4954

Lux Associates  
20 Sunland Drive  
Chico, CA 95926  
(916) 343-5033

Johnson computers  
Box 523  
Medina, Ohio 44256  
(216) 725-4560

Laboratory Microcomputer Consultants  
P.O. Box 84  
East Amherst, NY 14051  
(716) 689-7344

Falk-Baker Associates  
382 Franklin Avenue  
Nutley, NJ 07110  
(201) 661-2430

Perry Peripherals  
P.O. Box 924  
Miller Place, NY 11764  
(516) 744-6462

Circle No. 27

## Passing Parameters on the Stack

The favorite method for passing parameters used by many high-level languages such as Pascal is passing the parameters on a stack. The 6809, 68000, and 16032 are extremely well suited for passing data to and from procedures on a stack. The 6502 is, unfortunately, poorly suited for this application.

The 6502's problem with passing parameters on the stack is that the stack is of a very limited size (256 bytes). Furthermore, it's hard to get at data stored on the stack before a subroutine call. Nevertheless, there are times when pushing data onto the stack is the easiest way of passing data to a subroutine, especially if it is recursive. Although difficult, such parameter passing techniques are not impossible to perform on the 6502.

To pass data to a 6502 subroutine on the stack simply push the data onto the stack and call the routine as follows:

```
LDA PARM1
PHA
LDA PARM2
PHA
LDA PARM3
PHA
LDA PARM4
PHA
LDA PARM4 + 1
PHA
JSR SUBROUTN
```

There are two important points to keep in mind when passing data to a 6502 subroutine in this fashion. First, don't forget that upon entering the subroutine the subroutine return address is on the top of the stack. Second, the data appears on the stack in the reversed order (i.e., PARM4 + 1 is on the top, PARM4 is below that, PARM3 is below PARM4, etc.). Upon entering SUBROUTN the 6502 stack would look like this:

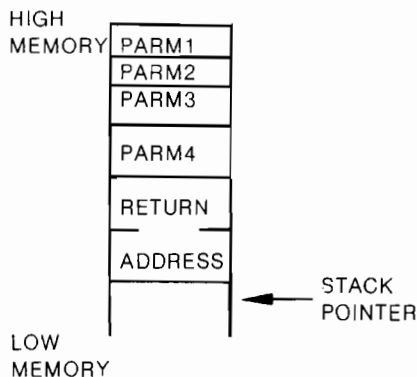

Note that the 6502 stack grows down and always points to the next available location on the stack. There are several ways to get the data off of the stack. One way is to POP it off (saving the return address in a temporary location and re-pushing it later) as follows:

```
SUBROUTN PLA
          STA RTNADR
          PLA
          STA RTNADR + 1
          PLA
          STA SPARM4 + 1
          PLA
          STA SPARM4
          PLA
          STA SPARM3
          PLA
          STA SPARM2
          PLA
          STA SPARM1
```

Push return address back onto the stack.

```
LDA RTNADR + 1
PHA
LDA RTNADR
PHA

RTS
```

This method of getting at parameters on the 6502 stack requires the use of some permanent memory locations. If you can't afford to use fixed memory locations to hold data, you can access it in place on the stack by copying the stack pointer into the X register and then using the index addressing mode:

```
TSX
LDA $107,X ;Get PARM1

LDA $106,X ;Get PARM2

LDA $105,X ;Get PARM3

LDA $104,X ;Get PARM4-LO

LDA $103,X ;Get PARM4-HI
```

Remove parameters from stack and return.

```
PLA ;Get LO return address
STA $106,X ;Save where rtn adrs
          ;must go
PLA ;Get HI return address
STA $107,X ;Save at correct spot
PLA ;POP parameters
          ;off stack
```

```
PLA
PLA
PLA
PLA
RTS
```

The routine shown here modifies the contents of the 6502 accumulator and X register. Most well-written subroutines will need to preserve the contents of the 6502 registers, which usually means they will need to be pushed onto the stack. If you push all three registers onto the stack, keep in mind that the offsets required to access PARM1, PARM2, PARM3, and PARM4 are increased by three. A better version of the former program that preserves all the 6502 registers is:

```
SUBRTN PHA ;Save Acc
       TXA
       PHA ;Save X
          ;register
       TYA
       PHA ;Save Y
          ;register
       TSX ;Get copy of
          ;SP register

LDA $10A,X ;Read
          ;PARM1

STA $109,X ;Store data
          ;into
          ;PARM2

LDA $108,X ;Read
          ;PARM3

LDA $107,X ;Get LO
          ;PARM4
          ;value

STA PARM4SAV
LDA $106,X ;Get HI
          ;PARM4
          ;value

STA PARM4SAV + 1
```

Prepare for subroutine return

```
LDA $105,X ;Get HI rtn
          ;adrs byte
STA $10A,X ;and
          ;reposition
          ;on the stack
LDA $104,X ;Get LO rtn
```



```

STA $109,X ;adrs byte
            ;and store
            ;back onto
            ;the stack
LDA $103,X ;Get Acc
            ;value

STA $108,X
LDA $102,X ;Get X
            ;register
            ;value

TAX
LDA $101,X ;Get Y
            ;register
            ;value

TAY
PLA        ;POP extra
PLA        ;junk off of
PLA
PLA
PLA        ;the stack
PLA
PLA        ;Get Acc
            ;value
RTS

```

LOW  
MEMORY

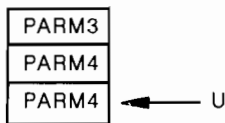

```

STD 11,S
PULS A,B,X,Y
LEAS 5,S ;Remove
            ;parameter
            ;storage

RTS

```

Here is the 6809 routine:

The stack, after an invocation of this subroutine, looks like this:

```

SUBRTN PSHS A,B,X,Y

LDA 4,U ;Get PARM1

LDA 3,U ;Get PARM2

LDA 2,U ;Get PARM3

LDD ,U ;Get PARM4

LEAU 5,U ;Remove PARMs
            ;from user
            ;stack
PULS A,B,X,Y ;Restore 6809
            ;registers
RTS ;All done

```

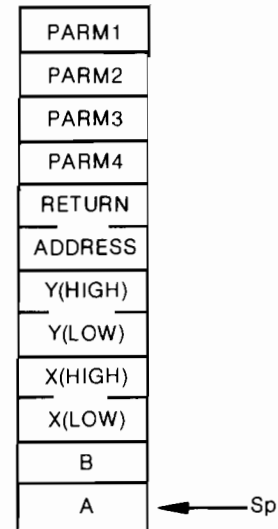

As you can probably tell, manipulating parameters on the 6502 stack is not a pleasant task.

The 6809 provides a much better method to access data on the stack than does the 6502. To begin, the 6809 supports two stacks: a hardware stack (where return addresses are kept) and a user stack (which is reserved for user-defined data). Both 6809 stack pointers can be used as index registers, so there's no need to waste one of the valuable index registers in order to access data on the stack. Finally, both stack pointers are 16 bits long so parameter data of any length (even when recursive subroutines are being used) can be accommodated.

While parameter data can be passed on either the hardware or the user stack, it is probably easiest to pass parameters on the user stack and use the hardware stack for storing return addresses and processor registers. Assuming that you have the same parameters defined for the 6502 example above, the calling sequence for a 6809 subroutine would be:

```

LDB PARM1
LDA PARM2
PSHU A,B
LDA PARM3
PSHU A
LDX PARM4
PSHU X
JSR SUBROUTN

```

After this code is executed the 6809 stack looks something like this:

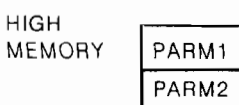

Notice that passing parameters on the 6809 stack is accomplished easily, especially when using the two stacks available to the user. Although it is a little more difficult to pass the parameters on the hardware stack (because the return address gets sandwiched in there) it is still much simpler to perform this task than it is to pass the data on the 6502 hardware stack. The 6809 code necessary to accomplish this task is:

```

SUBRTN PSHS A,B,X,Y ;Save 6809
            ;registers

LDA 12,S ;Get PARM1

LDA 11,S ;Get PARM2

LDA 10,S ;Get PARM3

LDD 8,S ;Get PARM4

```

Get ready to leave

```
LDD 6,S
```

The Motorola 68000 chip has eight address registers. A7 is the 68000 hardware stack pointer; the remaining seven registers can be treated like the user stack pointer on the 6809. The only difference between using the hardware stack pointer and any of the other address registers is that you must remember to respect the four-byte return address that is pushed onto the hardware stack during a subroutine call. The calling sequence for a 68000 subroutine is

```

MOVE.B PARM1,D0
MOVE.B D0,(SP)+ ;Note: SP is a
                ;synonym for A7
MOVE.B PARM2,D0
MOVE.B D0,(SP)+
MOVE.B PARM3,D0
MOVE.B D0,(SP)+
MOVE.B PARM4,D0
JSR SUBRTN

```

Since the hardware stack is being used in this particular case, you must remember to index past the return address when fetching data from the stack. The code to accomplish this is

```

SUBRTN MOVEM A0-A6/ ;Save registers
        D0-D7,
        -(SP)
MOVE.B 68(SP), ;Get PARM1
        D0

```

```

MOVE.B 67(SP), ;Get PARM2
      D1

MOVE.B 66(SP), ;Get PARM3
      D1

MOVE.W 64(SP), ;Get PARM4
      D1

MOVE.L (SP),D0 ;Move return
              ;address down
MOVE.L D0,4(SP);four bytes
MOVEM (SP)+,
      A0-A6/
      D0-D7
ADDA #4,SP ;Adjust stack
RTS ;pointer

```

The National Semiconductor 16032 chip was designed with a stack architecture in mind. For this reason it handles parameters passed on the stack quite well. Assuming you have the same parameters as used in the previous three examples, the calling sequence for a 16032 subroutine would be:

```

MOVEB PARM1,TOS
MOV B PARM2,TOS
MOV B PARM3,TOS

```

```

MOVW PARM4,TOS
JSR SUBRTN

```

You can see that it is much easier to push the data onto the stack with the 16032 than it was with the 6502, 6809, and 68000 microprocessors. The 16032 fully supports memory-to-memory data transfers, alleviating the problem of having to load the data into a register and then pushing it onto the stack.

Although the 16032 has only one hardware stack, the instruction set recognizes that the return address will be placed on top of the parameters and allows you to make adjustments for this. To access the parameters on the stack you would use the code

Save the NS16032 general purpose registers and copy the stack pointer into the 16032 frame pointer. This also allocates zero bytes of local storage for this particular subroutine.

```

SUBRTN ENTER [R0,R1,R2,R3,R4,
             R5,R6,R7],0

```

```

MOV B 6[FP],R0 ;Get PARM1

```

```

MOV B 5[FP],R0 ;Get PARM2

```

```

MOV B 4[FP],R0 ;Get PARM3

```

```

MOVW 2[FP],R0 ;Get PARM4

```

Now close up shop and quit

```

EXIT [R0,R1, ;Restore
      R2,R3, ;registers
      R4,R5, ;Return and pop
      R6,R7] ;parameters
RTS 5

```

*"Passing Parameters" will conclude next month.*

You may contact the author at Lazer MicroSystems, Inc., 1791 Capital Unit G, Corona, CA 91720.

**MICRO**

**Revised Edition  
Now Available!**

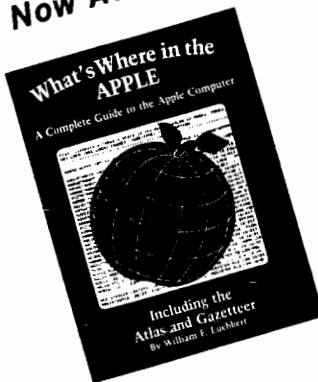

**All New Text Added To The Original Atlas And Gazetteer...**

## **"What's Where in the Apple"** A Complete Guide to the Apple Computer.

**This revised edition of the famous Apple Atlas will:**

- provide you with more information on the Apple's memory than is available elsewhere
- guide you with a numerical Atlas and an alphabetical Gazette — to over 2000 memory locations of PEEKs, POKEs and CALLs
- give you names and locations of various Monitor, DOS, Integer BASIC and Applesoft routines and tell you what they're used for
- enable you to move easily between BASIC and machine language
- guide you through the inner workings and hidden mechanisms of the Apple

All Apple users will find this book helpful in understanding their machine and essential for mastering it. The Atlas and the All New Guide are now available in one 256-page Wire-O-Bound book for only **\$24.95**.

If you own the original **What's Where in the Apple** purchase **The Guide** to complete your edition. This 128-page Wire-O-Bound version contains all the new material to be used with the memory map and atlas. Don't miss this opportunity to complete your edition of **What's Where in the Apple**. Order your copy of **The Guide** now...only **\$9.95**

Please Rush  **What's Where in the Apple @ \$24.95 (plus \$2.00 s/h)**  
 **The Guide @ \$9.95 (plus \$2.00 s/h)**

I'm paying by  Check  MO  VISA  MasterCard

Name \_\_\_\_\_

Credit Card # \_\_\_\_\_

Address \_\_\_\_\_

Card Expires \_\_\_\_\_

Total Enclosed \$ \_\_\_\_\_

City \_\_\_\_\_

State \_\_\_\_\_

Zip \_\_\_\_\_

**Mail to: MICRO, 34 Chelmsford Street, P.O. Box 6502, Chelmsford, MA 01824**

**Or Call Toll-Free: 1-800-354-8118** (In PA, 1-800-662-2444)

Circle No. 28

**SAVE  
20%!!!!**

**Subscribe  
to**

**MICRO™**

**Use This Postage  
Paid Card to Order  
the Next 12 Issues  
of MICRO and SAVE  
\$6.00 Off  
Newsstand Price!**

**MICRO™**

**SAVE 20%**

Yes! Enter my subscription to MICRO, and send me the next 12 issues for just **\$24.00**. I save **\$6.00** off the newsstand price!

Name \_\_\_\_\_

Address \_\_\_\_\_

City \_\_\_\_\_

State \_\_\_\_\_ Zip \_\_\_\_\_

I'm paying by  Check  MO  VISA  MasterCard

Card # \_\_\_\_\_ Exp. Date \_\_\_\_\_

Signature \_\_\_\_\_

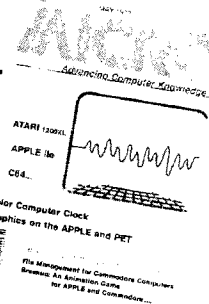

**I OWN A:**

Commodore 64  VIC-20  
 Apple  PET  
 Atari 400  Atari 800  
 Other: \_\_\_\_\_

**For Faster Service Call:**  
**1-800-345-8112**  
**(In PA: 1-800-662-2444**  
**VISA or MasterCard Only**

**A Feast Of  
Computing  
Ideas...**

**Order These  
Books From**

**MICRO™**

**MICRO™ Books**

**NEW for VIC-20 Users!  
Mastering Your VIC-20  
With 8 BASIC Projects**

A book that makes learning to program your VIC-20 fun! Contains 8 projects and programs. Games, utilities — even a VIC-20 version of "VisiCalc." All 8 programs on cassette to help you learn faster.

Mastering the VIC-20 @ \$23.95

**NEW for OSI Users!  
MICRO on the OSI**

Includes Machine-Language enhancements and BASIC Aids, hardware modifications for enhanced/reversed video, programs for control code and upper/lower case entry. A valuable programming tool.

Micro on the OSI @ \$19.95

**Best Sellers for  
APPLE Users!  
MICRO on the APPLE**

Programming aids, utilities, games, enhancements. Together Volumes 1, 2, and 3 contain over 100 programs on diskette. Fully documented and explained.

3-Volume Gift-Boxed @ \$59.95  
 Vol.1  Vol.2  Vol.3 \$24.95 ea.

Please rush the MICRO Books I've checked above to:

Name \_\_\_\_\_

Address \_\_\_\_\_

City \_\_\_\_\_ State \_\_\_\_\_ Zip \_\_\_\_\_

(Allow 6-8 weeks for delivery)

I'm paying by:  Check  MO  
 VISA  MC

Total Enclosed: \$ \_\_\_\_\_  
(Add \$2.00 s/h per book. MA res. add 5% tax)

Visa/MC # \_\_\_\_\_

Exp. Date: \_\_\_\_\_

**MICRO™**

**Reader  
Service...**

**For More  
Information  
On The  
Advertisers  
In This Issue!**

**MICRO™ Reader Service Card**

The numbers below correspond to the numbers imprinted on the advertisements in this issue of MICRO. This card valid for 90 days only.

Mail information to:

Name \_\_\_\_\_

Address \_\_\_\_\_

City \_\_\_\_\_ State \_\_\_\_\_ Zip \_\_\_\_\_

1	2	3	4	5	6	7	8	9	10	11	12	13
14	15	16	17	18	19	20	21	22	23	24	25	26
27	28	29	30	31	32	33	34	35	36	37	38	39
40	41	42	43	44	45	46	47	48	49	50	51	52
53	54	55	56	57	58	59	60	61	62	63	64	65
66	67	68	69	70	71	72	73	74	75	76	77	78
79	80	81	82	83	84	85	86	87	88	89	90	91
92	93	94	95	96	97	98	99	100	101	102	103	104



NO POSTAGE  
NECESSARY  
IF MAILED  
IN THE  
UNITED STATES

**BUSINESS REPLY CARD**  
FIRST CLASS PERMIT NO. 60, CHELMSFORD, MA

POSTAGE WILL BE PAID BY ADDRESSEE



34 Chelmsford Street  
P.O. Box 6502  
Chelmsford, MA 01824



**SAVE  
20%!!!!**  
**Subscribe  
to  
MICRO**

Use This Postage  
Paid Card to Order  
the Next 12 Issues  
of MICRO and SAV  
**\$6.00 Off**  
Newsstand Price!



NO POSTAGE  
NECESSARY  
IF MAILED  
IN THE  
UNITED STATES

**BUSINESS REPLY CARD**  
FIRST CLASS PERMIT NO. 60, CHELMSFORD, MA

POSTAGE WILL BE PAID BY ADDRESSEE



34 Chelmsford Street  
P.O. Box 6502  
Chelmsford, MA 01824



**A Feast of  
Computing  
Ideas...**

**Order These  
Books From**



NO POSTAGE  
NECESSARY  
IF MAILED  
IN THE  
UNITED STATES

**BUSINESS REPLY CARD**  
FIRST CLASS PERMIT NO. 60, CHELMSFORD, MA

POSTAGE WILL BE PAID BY ADDRESSEE



34 Chelmsford Street  
P.O. Box 6502  
Chelmsford, MA 01824



**Reader  
Service..**

**For More  
Information  
On The  
Advertisers  
In This Issue**



# FOR YOUR APPLE II

## Industry standard products at super saver discount prices

### SOFTWARE

<b>ARTSCI</b>	List	SGC
Magicalc .....	\$149.00	\$ 99.00
Magic Window II .....	149.00	99.00
DBase (Apple) .....	695.00	475.00
<b>BRODERBUND</b>		
Payroll .....	\$395.00	\$295.00
Choplifter .....	34.95	25.00
Arcade Machine .....	44.95	29.95
Serpentine .....	34.95	25.00
Home Accountant .....	74.95	55.00
Home Accountant Plus .....	150.00	109.00
<b>DATAMOST</b>		
Snackattack .....	\$ 29.95	\$ 22.50
Thief .....	29.95	22.50
Swashbuckler .....	34.95	24.95
Zork I, II, or III .....	39.95	27.95
Starcross .....	39.95	27.95
Format II .....	250.00	175.00
System Saver & Fan .....	59.95	49.00
Multiplan .....	275.00	199.00
<b>ON LINE</b>		
Mystery House .....	\$ 24.95	\$ 19.95
Cranston Manor .....	34.95	24.95
Frogger .....	34.95	24.95
Screen Writer II .....	129.95	99.95
Memory Management II .....	49.95	39.95
<b>PEACHTREE</b>		
GL, AR, AP,		
Inventory, Payroll .....	ea. \$400.00 ea.	\$295.00
Micro Buffer II .....	299.00	249.00
<b>SENSIBLE SOFTWARE</b>		
Super Disk Copy III .....	\$ 29.95	\$ 22.95
DOS Plus .....	24.95	17.95
<b>SERIOUS SOFTWARE</b>		
Bandits .....	\$ 34.95	\$ 26.95
Epoch .....	34.95	26.95
Fly Wars .....	29.95	22.95
Gorgon .....	39.95	29.95
Sneakers .....	29.95	22.95
Joy Port .....	74.95	59.95
Wizardry .....	49.95	34.95
Night of Diamonds .....	34.95	26.95
Star Maze .....	34.95	26.95
PFS .....	125.00	89.95
PFS Report .....	95.00	69.95
PFS Graph .....	125.00	89.95
Data Capture 4.0 .....	64.95	49.95
Merlin/Assembly Lines .....	119.95	89.95
Merlin .....	64.95	49.95
ASCII Express Pro .....	129.95	99.95
Transend II .....	149.00	119.00
Transend I .....	89.00	65.00
DB Master .....	229.00	165.00
DB Utility Pack .....	99.00	79.00
<b>STRATEGIC SIMULATION</b>		
All Software .....	\$ 59.95	\$ 39.95
All Software .....	39.95	27.95
<b>SYNERGISTIC SOFTWARE</b>		
Wilderness & Dungeon .....	\$ 32.50	\$ 24.95
GPLLE .....	64.95	49.95
TG Joystick .....	59.95	45.00
Select-A-Port .....	59.95	45.00
Wordstar .....		325.00
Spellstar .....		175.00
SuperCalc .....		175.00
VisiCalc .....		179.00

## SPECIAL AND NEW

### FRANKLIN ACE 1000 COMPUTER

Hardware and Software compatible with Apple II ..... \$950

FRANKLIN ACE 1000 COMPUTER plus DISK DRIVE, CONTROLLER, and MAGICALC ..... \$1,250

### EXPAND-A-RAM™ PLUS MAGICALC™

Everything that Visicalc™ can do and much more — plus additional memory. Fully compatible with Visicalc. Includes DOS, CP/M, Pascal Disk Emulator. No preboot or Apple modification required.

64K EXPAND-A-RAM plus MAGICALC ..... \$375

128K EXPAND-A-RAM plus MAGICALC ..... \$449

### APPLEurance II™

Diagnostic Disk Controller and System Assurance Package. Standard disk controller plus automatic check of system hardware ..... \$99

### 5 1/4" DISK DRIVE

Use with either standard Apple II disk drive or APPLEurance II ..... \$249

### GRAPHITTI CARD

Prints HIRES page 1 or 2 from onboard firmware. Features: True 1:1 aspect ratio, prints emphasized mode, reverse mode, rotates 90 degrees ... plus more. Compare all this with the Grappler. We think you'll agree that this is the best graphics card on the market. Specify for use with EPSON, NEC-8023, C-ITOH Prowriter, or Okidata.

(List: \$125) ..... \$89

### PARALLEL PRINTERS

#### NEC 8023 or C-ITOH 8510

(Virtually identical) Specifications: • 100 CPS dot matrix printer • 80 column print—136 characters per line • Tractor/friction feed • 7 different print fonts included • 2K printer buffer • Proportional spacing • Bit image graphics and graphic symbols.

NEC 8023 or C-ITOH ..... \$475

NEC 8023 or C-ITOH 8510 with Parallel Interface and Cable ..... \$550

EPSON 100 with Parallel Interface and Cable ..... \$775

BROTHER Daisywheel Printer ..... \$895

### VERSACard FROM PROMETHEUS

Four cards on one! With true simultaneous operation. Includes: (1) Serial Input/Output Interface, (2) Parallel Output Interface, (3) Precision Clock/Calendar, and (4) BSR Control. All on one card. Fully compatible with CP/M\* and Apple Pascal\*.

(List: \$249) ..... \$169

### WORD PROCESSING SPECIAL WITH WORDSTAR AND SUPERCALC!

Do professional word processing on your APPLE. All necessary hardware and software included. Complete 80 column video display, enhanced character set, 16K memory board, Z-Card with CP/M\* software, Wordstar and word processing software and SuperCALC.

(List: \$1,228) ... Special at \$795

<b>Z-80 CARDS</b>	List	SGC
Microsoft Softcard Z-80 ...	\$399.00	\$289.00
ALS Synergizer .....	749.00	595.00
U-Z-80 Processor Board ...		125.00
Microsoft+Premium Syst. . .		595.00

<b>80-COLUMN CARDS</b>		
Smarterm 80-Col Display ..	\$345.00	\$225.00
Smarterm Expanded Character Set .....		40.00
Combination Smarterm & Exp. Char. Set .....		260.00
Videx Videoterm .....		275.00
Videx Enhancer II .....	149.00	125.00
Videx VisiCalc Preboot .....	49.95	45.00

<b>MODEMS FOR YOUR APPLE II</b>		
Hayes Smartmodem 300 ...		\$229.00
Hayes Smartmodem 1200 ...	699.00	550.00
Micromodem II .....		279.00
Hayes 100 Baud .....		Call
Apple Cat II .....	389.00	299.00
D Cat Modem .....	199.00	175.00

<b>MONITORS</b>		
Amdek 300G Green .....		\$159.00
Color-Taxam RGB with Interface .....		395.00

<b>PARALLEL INTERFACE</b>		
Centronics Compat. PRT-1 . .		\$ 69.00

<b>JOYSTICK</b> Replaces two Apple Paddle Controllers . .	\$ 59.00	\$ 39.00
---	----------	----------

<b>FUNCTION STRIP</b> .....	\$ 79.00	\$ 65.00
-----------------------------	----------	----------

<b>MEMORY EXPANSION</b>		
Prometheus 16K RAM Module complete .....	\$169.00	\$ 65.00

<b>5 1/4" FLOPPY DISKS</b>		
Box of 10 with hub rings		
With other purchase .....		\$ 19.95
Without other purchase .....		23.00

All equipment shipped factory fresh. Manufacturers' warranties included. California customers add 6 1/2% tax. Include payment by personal check, money order, or cashier's check with order and SGC will pay shipping charge. Call for amount of shipping charge when paying by credit card.

All items are normally in stock

**(415) 490-3420**

... And we'll be here to help after you receive your order. Feel free to call the SGC Technical Staff for assistance.



**The mail order specialists**  
342 Quartz Circle, Livermore, CA 94550

Circle No. 29

# Real Time Clock for Color Computer

by John Steiner



Use this subroutine to add a real-time clock and date function to your programs.

**TIMES/SUB**  
requires:  
TRS-80 Color Computer

After owning my TRS-80C for one year, I have few complaints and a lot of praise. The graphics are impressive for such a low-priced system, and the number of external hook-ups is more than adequate for the average user. Plus, you get the built-in RS-232 and joystick ports, which are extra cost on many other systems.

I finally purchased a disk drive and soon became accustomed to the invisible disk operating system. The DOS is an integral part of extended BASIC in the color computer. But I was jealous of my friends who owned the Model III with the built-in **TIMES** and **DATE\$** commands.

One of the applications I have for my machine is a mailing list and file system for the local ham radio and computer clubs. It would be nice for a program to tell me the last time a file was created, or updated. I suffered with this shortcoming for many weeks until I saw the light.

The color computer has a built-in elapsed timer, which on power up counts from 0 to 65535. The timer is available only in Extended BASIC, and I have heard that it is interrupt driven, updating approximately every 1/60th of a second.

For the cost of a few extra reserved variables, I wrote a subroutine that can be inserted into any program. Listing 1 contains the routine, which begins at 60000.

You need to make only a couple modifications to any individual pro-

gram to use the routine. After clearing memory and dimensioning strings, call the subroutine that begins at 60000, and immediately thereafter call the routine at 60100 as in the example.

```
10 CLEAR200:DIM N$(100)
20 GOSUB 60000:GOSUB 60100
```

The routine at 60000 enters the correct date and time into **DATE\$** and **TIMES**. Lines 60100 to 60160 update the correct time using the timer function.

Now, throughout the program, sprinkle **GOSUB 60100** sparingly. Suitable places for the **GOSUBs** are at the beginning of menu screens, just before and after long sorts, and *always* just before printing **TIMES** to the printer, screen, disk, or cassette.

The timer will keep reasonably correct time, unlike most software clocks, because it is interrupt driven.

When the routine is called, line 60100 determines whether or not one minute has expired. If it has not, no time is wasted, and the program reassigns or, in the case of initialization, assigns the current time to **TIMES**. If it has been a while since the last **GOSUB**, one minute is subtracted from the value of the timer and added to the variable **MIN**. If the hour must be updated, it is also done in line 60120. Another check is made to see if the timer is greater than 3550. This indicates that more than one minute has passed since the last update. If this is the case, the program loops back to 60110 and again updates the timer, hour, and minute variables.

You may find that the clock will gain or lose time. By changing the value of **TIMER** in lines 60100, 60110, and 60130, you can speed up or slow

down the clock. You can make it as accurate as you want.

After the routine determines that the time is now correct, lines 60140 and 60150 format and assign the correct time to **TIMES**. Your program can get by without updating the time for 18 minutes, before the **TIMER** function in the color computer resets itself, so be sure that it is accessed more often than that. Again, it's a good idea to put the access routine in the menus, which are usually accessed often.

Now your computer has **TIMES** and **DATE\$** capacity too!

## Listing 1: TIMES/Subroutine

```
50000 '*****
50010 '* TIMES/SUB *
50020 '* JOHN STEINER *
50030 '* APRIL 11, 1982 *
50040 '*****
50050 'TO CHANGE TIMER SPEED ADJUST
      LINES 60100,60110 AND 60130
60000 CLS:PRINT:PRINT"ENTER TODAY'S DATE"
60010 LINEINPUT"MM/DD/YY: ";DATE$
60020 LINEINPUT"ENTER THE CORRECT HOUR: ";HOURS$
60030 IFVAL(HOURS$) < 10RVAL(HOURS$) > 12THEN
      PRINT"INCORRECT TIME":GOTO60020
60040 HOUR=VAL(HOURS$)
60050 LINEINPUT"ENTER THE CORRECT MINUTE: ";MIN$
60060 IFVAL(MIN$) < 0RVAL(MIN$) > 59THEN
      PRINT"INCORRECT MINUTES":GOTO60050
60070 MIN=VAL(MIN$)
60080 TIMER=0
60090 RETURN
60100 IFTIMER < 3550THEN60140
60110 TIMER=TIMER-3550
60120 MIN=MIN+1:IFMIN > 59THENMIN=MIN-60:
      HOUR=HOUR+1:IFHOUR > 12THENHOUR=HOUR-12
60130 IFTIMER > 3550THEN60110
60140 MIN$=STR$(MIN):IFLEN(MIN$)=2THEN
      MIN$="0"+RIGHT$(MIN$,1)ELSE
      MIN$=RIGHT$(MIN$,2)
60150 TIMES=STR$(HOUR)+"."+MIN$
60160 RETURN
```

John Steiner is an electronics instructor in the Fargo, ND school system. His hobbies include programming, amateur radio, and writing. He has written articles for several publications and is at present completing a book on Electronics. Also in the works is a book on BASIC. John's computer system includes a TPD-100 with disk system, and an Epson MX-80 printer.

# VIDEO TERMINAL BOARD 82-018

This is a complete stand alone Video Terminal board. All that is needed besides this board is a parallel ASCII keyboard, standard NTSC monitor, and a power supply. It displays 80 columns by 25 lines of UPPER and lower case characters. Data is transferred by RS232 at rates of 110 baud to 9600 baud — switch selectable. The UART is controlled (parity etc.) by a 5 pos. dip switch.

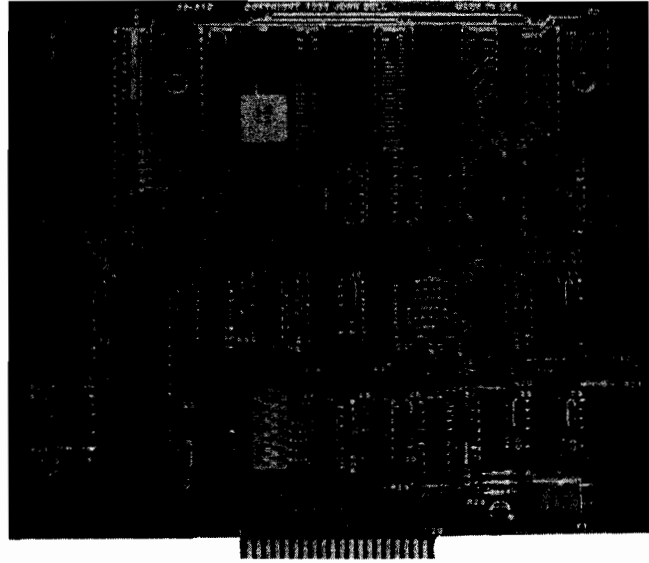

Complete source listing is included in the documentation. Both the character generator and the CRT program are in 2716 EPROMS to allow easy modification to your needs.

This board uses a 6502 Microprocessor and a 6545-1 CRT controller. The 6502 runs during the horz. and vert. blanking (45% of the time). The serial input port is interrupt driven. A 1500 character silo is used to store data until the 6502 can display it.

## Features

- 6502 Microprocessor
- 6545-1 CRT controller
- 2716 EPROM char. gen.
- 2716 EPROM program
- 4K RAM (6116)
- 2K EPROM 2716
- RS232 I/O for direct connection to computer or modem.
- 80 columns x 25 line display
- Size 6.2" x 7.2"
- Output for speaker (bell)
- Power +5 700Ma.  
+12 50Ma.  
-12 50Ma.

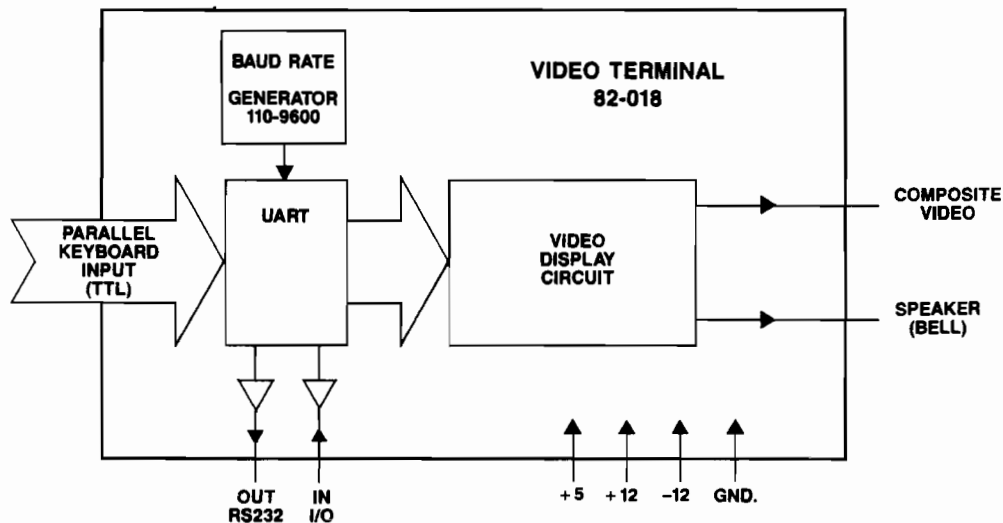

This board is available assembled and tested, or bare board with the two EPROMS and crystal.

Assembled and tested	#82-018A	\$199.95
Bare board with EPROMS and crystal	#82-018B	\$ 89.95

Both versions come with complete documentation.



## JOHN BELL ENGINEERING, INC.

ALL PRODUCTS ARE AVAILABLE FROM JOHN BELL ENGINEERING, INC. • 1014 CENTER ST., SAN CARLOS, CA 94070  
ADD SALES TAX IN CALIFORNIA • ADD 5% SHIPPING & HANDLING 3% FOR ORDERS OVER \$100

SEND \$1.00 FOR CATALOG

(415) 592-8411  
WILL CALL HOURS: 9am - 4pm

10% OUTSIDE U.S.A.  
ADD \$1.50 FOR C.O.D.



#249



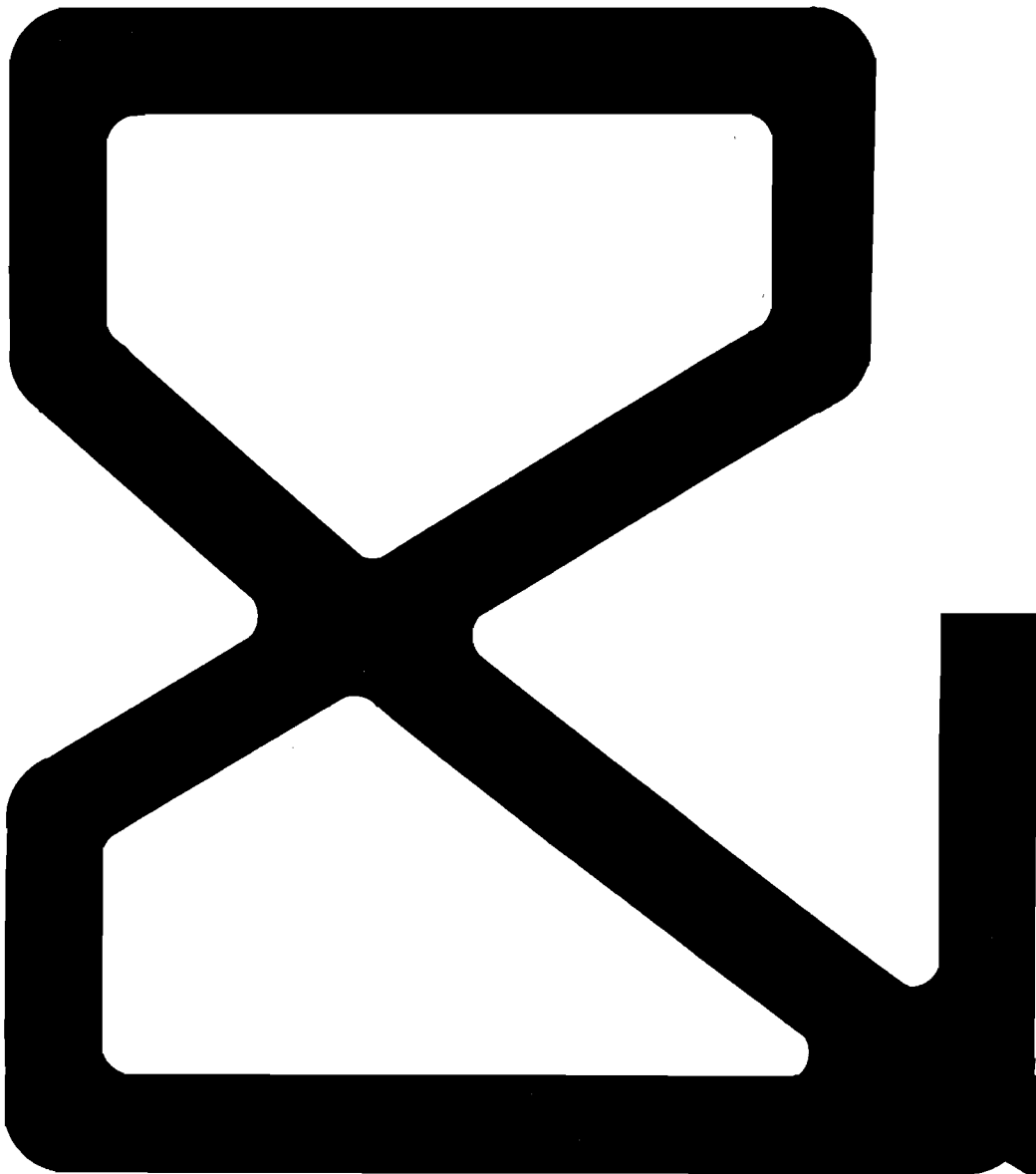

by David Dice

---

---

**A machine-language program to allow customized input routines.**

---

---

**AMPERGET**

requires:

Apple II with Applesoft BASIC

---

Many functions are not available with Applesoft's INPUT routine. For instance, have you ever had to input strings containing commas or colons? Would you like to use the 'ESC' key as an exit parameter? Or how about using the backspace key to back up to a previous line of data? One possibility is using the GET routine, but this method has disadvantages. You can GET the character and then concatenate

strings with a statement like GET X\$: TE\$ = TE\$ + X\$. However, you can no longer use the retype ( — >) or backspace ( < — ) keys to copy or delete material from the string. Another problem is that it accelerates the need for garbage collection — that annoying, time-consuming process of freeing up memory that happens when you do a lot of string swapping in Applesoft. I tempered the problem by developing &GET.

Initially my approach to using the retype and backspace keys involved the MID\$ command in a short Applesoft subroutine that found the correct part of the string. This worked at least as fast as I could type but there was some noticeable screen flicker. And because I was doing even more string manipulations, it compounded the problem of memory space!

When presented by a problem that BASIC doesn't solve efficiently you

have two alternatives. Quit, or try another language! In this case I wanted the program to run quickly, so the logical approach was to write the input routine in machine language. Fortunately, the procedure could be greatly simplified by using a number of monitor and Applesoft routines and pointers. The result was &GET.

&GET takes about half a page of memory. It could be assembled in an area not affected by the Applesoft program that calls it, and page 3 of memory (starting at \$300) is just such a convenient location. The &GET routine is accessed by a command using the syntax '&G,A\$' where A\$ can be any string variable. The & vector in byte \$3F5 contains a JMP code to the beginning of the routine. The first few lines of the program check to ensure that the correct syntax was used and find the location of the string variable specified. Provided that the syntax is right the



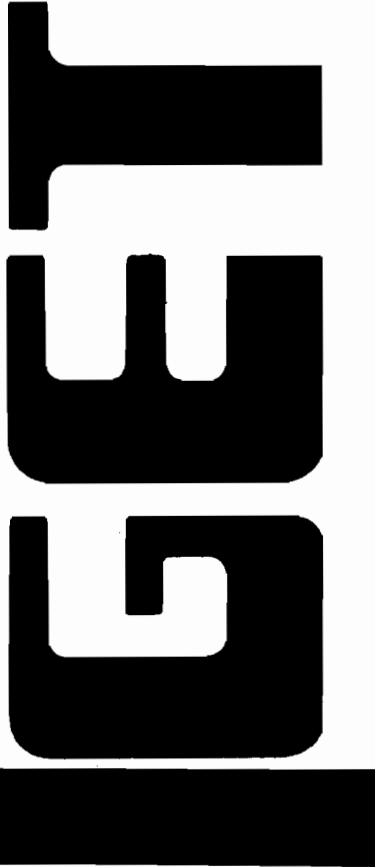

routine begins to input the string. If there is an error, then you will hear the Apple's beep and be presented with the message 'SYNTAX ERROR'.

You put the characters you pick up in the input buffer, page 2 of memory. This is where the Apple's normal input routine, GETLIN, stores characters; since you're not using GETLIN there won't be any problems.

First the buffer is cleared by filling it with spaces. You are now ready to get the data. The monitor input routine, RDKEY, is used to input a character. If the character is one of 'ESC', '←', '→', or 'RETURN' then special action is taken:

1. If 'ESC', then \$1B (decimal 27), the ASCII code for ESCAPE, is placed in the variable and the routine exits.
2. If '←', then the cursor is moved backwards and the length of the string is decremented. If an attempt

## Amperget Listing

```

*****
*
* &GET
*
* COPYRIGHT (C) 1983
*
* MICRO INK
* 34 CHELMSFORD ST.
* CHELMSFORD, MA 01824
*
* WRITTEN BY D. DICE
*
*****
*
* APPLESOFT ROUTINES AND POINTERS
*
BASL     EPZ $28
CHKCOM   EQU $DEBE
CHKSTR   EQU $DD6C
CHRGET   EPZ $B1
CROUT1   EQU $FDBB
COUT     EQU $FDED
ERROR    EQU $D412
PRETOP   EPZ $6F
GETSPA   EQU $E452
IN       EQU $200
PTRGET   EQU $DFE3
RDKEY    EQU $FDOC
RNGBEL   EQU $FF3A
SYNTAX   EPZ $10
VARPT    EPZ $83
NULL     EQU $00
SPACE    EQU $20
FORWARD  EQU $95
BACKWARD EQU $88
RETURN   EQU $8D
ESCAPE   EQU $9B
AMPER    EQU $3F6
*
*          ORG $300
*
* SET UP & JUMP
*
0300 A9 0B    55      LDA #BEGIN
0302 8D F6 03 56      STA AMPER
0305 A9 03    57      LDA /BEGIN
0307 8D F7 03 58      STA AMPER+$1
030A 60      59      RTS
60 *
61 * ENTRY POINT FROM AMPERSAND
62 *
030B C9 47    63 BEGIN  CMP 'G'          ;CHECK FOR 'G'
030D F0 05    64      BEQ START
030F A2 10    65      LDX #SYNTAX      ;SYNTAX ERROR
0311 4C 12 D4 66      JMP ERROR
0314 20 B1 00 67 START  JSR CHRGET
0317 20 BE DE 68      JSR CHKCOM
031A 20 E3 DF 69      JSR PTRGET
031D 20 6C DD 70      JSR CHKSTR
0320 A2 00    71      LDX #NULL          ; FILL THE BUFFER WITH SPACES
0322 A9 20    72 CLRBUF  LDA #SPACE
0324 9D 00 02 73      STA IN,X
0327 CA      74      DEX
0328 D0 F8    75      BNE CLRBUF
032A 20 0C FD 76 GETCHAR JSR RDKEY      ; READ THE KEYBOARD
032D C9 95    77      CMP #FORWARD      ; CURSOR AHEAD?
032F F0 1A    78      BEQ RDSCRN
0331 C9 88    79      CMP #BACKWARD     ; BACKSPACE?
0333 F0 1B    80      BEQ BACKWDS
0335 C9 8D    81      CMP #RETURN       ; RETURN?
0337 F0 35    82      BEQ RETURN1
0339 C9 9B    83      CMP #ESCAPE      ; ESCAPE?
033B F0 29    84      BEQ ESCAPE1
033D 20 ED FD 85 PRINT  JSR COUT
0340 9D 00 02 86      STA IN,X          ; STORE VALUE IN BUFFER
0343 E8      87      INX              ; INCREMENT COUNT OF ENTRIES
0344 E0 F8    88      CFX #F8          ; IF GREATER THAN 248
0346 B0 50    89      BCS BELL        ; THEN RING BELL
0348 4C 2A 03 90      JMP GETCHAR      ; ELSE GET NEXT CHARACTER
034B B1 28    91      RDSCRN  LDA (BASL),Y    ; READ THE SCREEN
034D 4C 3D 03 92      JMP PRINT
0350 CA      93      BACKWDS  DEX
0351 E0 FF    94      CFX #FF          ; IF < 0 THEN

```

is made to back up past the end of the line, then the variable contains the code for BACKSPACE, \$8 and the routine exits.

3. If ' → ', then RDSCRN picks up the current character displayed on the monitor.
4. If 'RETURN', then the routine exits.

The Applesoft routine GETSPA is used to find space for the string variable, the high bit is stripped off, and then TSFR moves the input buffer to the variable specified in the &G,A\$ statement. If the data is not one of these special characters, then it is added to the end of the input buffer. A check is made on the length of the input string. At 249 characters the bell begins to ring. At 255 characters the buffer has been filled, a backslash is printed, and the routine starts over.

The Applesoft program AMPER-GET.DEMO (listing 2) shows how the routine can be used. The subroutine, GET THE DATA, uses the &GET. You may type in data, use the backspace and retype keys normally, and end a line by typing 'RETURN'. If you type a 'RETURN' without any entry, then the current value of the variable L1\$ or L2\$ is left unchanged. If you backspace past the beginning of INPUT LINE 2, then AMPERGET.TEST will take you back to INPUT LINE 1. Line 270 loops back to the beginning of the data input routine so that it is impossible to back up past the beginning of GET THE DATA. Typing 'ESC' at any time clears all the entries and repeats the GET THE DATA subroutine.

You lose the cursor editing functions ESC I,J,K,M (or A,B,C,D) by using this routine. This is a small price to pay for getting the ESC key back for an 'escape' function, and the ability to enter any character into an Applesoft string.

David Dice holds a Ph.D. in chemistry and a Bachelor's degree in education. He has taught chemistry, science, math, and computer science from the Junior High to the University levels. Mr. Dice is owner of Digipac Computer Consulting, a company specializing in the production and distribution of quality educational and business software, and a fulltime high school teacher. You may contact him at Digipac, 907 River St. E., Prince Albert, Sask. S6V 0B3.

```

0353 FO 06      95      BEQ OUT      ; EXIT WITH BACKSPACE
0355 20 ED FD   96      JSR COUT     ; ELSE PRINT THE VALUE
0358 4C 2A 03  97      JMP GETCHAR
035B A2 00      98 OUT   LDX #NULL    ; EXIT WITH BACKSPACE
035D A9 08      99      LDA #BACKWARD-$80
035F 9D 00 02 100     STA IN,X
0362 E8         101     INX
0363 4C 6E 03 102     JMP RETURN1
0366 A2 00      103     ESCAPE1 LDX #NULL    ; EXIT WITH ESCAPE CODE
0368 A9 1B      104     LDA #ESCAPE-$80
036A 9D 00 02 105     STA IN,X
036D E8         106     INX
036E 8A         107     RETURN1 TXA      ; TRNSFR LEN TO ACCUM.
036F A0 00      108     LDY #NULL    ; AND STORE IT
0371 91 83      109     STA (VARPT),Y
0373 20 52 E4 110     JSR GETSPA   ; GET SPACE FOR STRING
0376 A0 01      111     LDY #$01
0378 A5 6F      112     LDA FRETOP
037A 91 83      113     STA (VARPT),Y ; STORE ADDRESS OF STRING
037C C8         114     INY
037D A5 70      115     LDA FRETOP+1
037F 91 83      116     STA (VARPT),Y
0381 A0 00      117     LDY #NULL
0383 B1 83      118     LDA (VARPT),Y
0385 AA         119     TAX
0386 A8         120     TAY
0387 CA         121     TSFR   DEX
0388 88         122     DEY
0389 BD 00 02 123     LDA IN,X      ; GET CHARACTER
038C 29 7F      124     AND #$7F     ; CLEAR $80 BIT
038E 91 6F      125     STA (FRETOP),Y ; STORE CHARACTER
0390 E0 00      126     CPX #NULL
0392 D0 F3      127     BNE TSFR
0394 20 8B FD 128     JSR CROUT1   ; EXIT AND CLEAR LINE
0397 60         129     RTS
0398 E0 FF      130     BELL   CPX #$FF     ; IF STRING LEN EQUALS 255
039A FO 06      131     BEQ END     ; THEN DO AGAIN
039C 20 3A FF 132     JSR RINGBEL ; ELSE RING THE BELL
039F 4C 2A 03 133     JMP GETCHAR
03A2 A9 DC      134     END     LDA #$DC     ; PRINT SLASH AND START OVER
03A4 20 ED FD 135     JSR COUT
03A7 20 8B FD 136     JSR CROUT1
03AA 4C 22 03 137     JMP CLRBUF
03AD          138     END

```

DICE AMPERGET.DEMO

```

10 REM *****
20 REM *      AMPERGET.DEMO
30 REM *      BY DAVID DICE
40 REM *      COPYRIGHT (C) 1983
50 REM *      MICRO INK
60 REM *****
70 ES$ = CHR$(27):CB$ = CHR$(
8):D$ = CHR$(4)
80 PRINT D$;"BRUN AMPERGET.OBJ"
90 HOME
100 PRINT "'RETURN'=COPY 'ESC'=V
    OID '<-'=BACKSPACE"
110 VTAB 3: PRINT "INPUT LINE 1:
120 VTAB 13: PRINT "INPUT LINE 2:
130 GOSUB 170
140 IF ES THEN L1$ = "":L2$ = ""
    : GOTO 90
150 GOSUB 310
160 END
170 ES = 0
180 VTAB 3: HTAB 15: PRINT L1$
190 VTAB 3: HTAB 15: & G,A$
200 IF A$ = "" THEN A$ = L1$: VTAB
    3: HTAB 15: PRINT L1$
210 IF A$ = CB$ THEN 180
220 IF A$ = ES$ THEN ES = 1: RETURN
230 L1$ = A$
240 VTAB 13: HTAB 15: PRINT L2$
250 VTAB 13: HTAB 15: & G,A$
260 IF A$ = "" THEN A$ = L2$: VTAB
    13: HTAB 15: PRINT L2$
270 IF A$ = CB$ THEN 180
280 IF A$ = ES$ THEN ES = 1: RETURN
290 L2$ = A$
300 RETURN
310 HOME
320 PRINT "THE VALUES ENTERED WERE:
330 PRINT "LINE 1: ";L1$
340 PRINT : PRINT "LINE 2: ";L2$
350 RETURN

```



**OSI — OSI — OSI — OSI**  
**192K RAM**  
**BOARD**

**ONLY \$895**

*The CCS - 192K is divided into  
4 - 48K bank partitions.*

*Each board can be dip switch  
selected for 1 of 4 192K banks.*

*When combined with our CPU  
the 192K RAM Board implements a  
four user computer system at a  
logic cost of \$1595 (special package price).*

*Combine this logic package  
with our Tilios Operating System  
and you have a multi-user computer  
with throughput that has to be  
seen to be believed.*

7250 COMMERCE CIRCLE EAST • FRIDLEY, MINNESOTA 55432 • PHONE (612) 574-9493  
(800) 328-2419

Circle No. 31

# Modifying and Using MAE on the PET

by F. Arthur Cochrane

## Modifications to the MAE assembler described here allow output to an ASCII printer and listing output to a disk file.

**M**AE is the Macro Assembler Text Editor for the PET written in fast machine-language code by Carl Moser of Eastern House Software. There are versions for 3.0 ROMs, 4.0 ROMs, and 8032 PETs. MAE has many powerful features, including macros and conditional assembly.

### Patches to MAE for ASCII Printers

The following patches were provided by Carl Moser for ASCII printers:

1. To prevent sending a cursor down character before each line replace the following code with five NOPs:

```
74C4 A9 11      LDA #S11
74C6 20 53 72   JSR $7253
```

It will look like this:

```
74C4 EA EA
74C6 EA EA EA
```

2. To eliminate line feeds make the following changes:

	From	To
6467	20	60
5553	0A 0A 0A	0D 0D 0D
556D	0A 0A	0D 0D
5571	0A	0D
5572	12	07
558D	0A	0D
5584	0A	0D
55A1	0A 0D 0A	0D 0D 0D
68F5	C9 0A	C9 0D

3. To output true ASCII instead of PET ASCII change 7210 20 B4 74 JSR \$74B4 to 20 53 72 JSR \$7253.

4. If you are using paper wider than 80 columns then the output can be widened slightly by changing the following to six NOPs [EA]:

```
6027 C0 39      CPY #S39
6029 90 02      BCC $602D
602B A0 39      LDY #S39
```

5. If your printer is not device 4 then change 725A from 4 to your printer's device number.

6. To fix the STP (word processor) for no linefeeds to the printer make the following changes:

	From	To
0931	20 36 09	EA EA EA
0934	A9 0A	EA EA
0963	C9 0A	C9 0D
099F	C9 0A	C9 0D

7. To avoid losing an occasional character with any printer, enter these patches:

```
7256 85 2B 78
726D A5 2B 58
```

### Send Listing Output to Disk

If you wish to send the listing to a disk file instead of a printer, then this patch will allow it. The following code tells the printer to listen.

```
7259 A9 04      LDA #S04
725B 85 D4      STA $D4
725D 20 D5 F0   JSR $F0D5 ($F0BA,
Upgrade BASIC)
7260 20 48 F1   JSR $F148 ($F12D,
Upgrade BASIC)
```

Change this code to the following to tell the disk to listen:

```
7259 EA EA
725B EA EA
725D EA EA EA
7260 20 F0 77   JSR $77F0
77F0 A9 08      LDA #8
77F2 85 D4      STA $D4
77F4 20 D5 F0   JSR $F0D5 ($F0BA,
BASIC 2.0)
77F7 A9 68      LDA #S68
77F9 4C 43 F1   JMP $F143 ($F128,
BASIC 2.0)
```

To use this disk output routine you must open the file in BASIC as OPEN8,8,8,"dr:name,s,w" then SYS to the MAE warm start (\$5003). Now when the TO IEEE command is given the output goes to the open file. When you are through with the file give the BA command to return to BASIC and CLOSE8 to close the file.

### Using the Relocating Loader

To start, all zero page locations that you want to be relocated should be assigned starting at location zero with the .DI pseudo-op. On the PET there are few locations in zero page to use. They are fixed and will be set with the .DE pseudo-op, but the .DI feature would be useful to develop software for another computer. The absolute (non-zero-page) locations used should be assigned with the .DI command starting at location \$0400, but be sure to keep the same relative relationships among

the labels that you desire in the final code. Now start assembly at location \$2000. Note that MAE defaults the start of assembly at location \$0400, not at location \$2000, so you must explicitly use the .BA pseudo-op.

Now assemble the file with the AS command. After the two passes, give the OU command with a file name to put the relocatable file onto disk. Once the output command has done its pass the relocatable loader is ready to be used.

When the loader asks for the file name, give it the name of the file created with the OU command. For the zero-page offset and absolute offset enter numbers to add to the zero page and absolute locations (as defined with the .DI command). This will assemble them at their correct addresses. On the PET these will usually be zero. Next, for the program execution offset, give the location (in hex) where you want the program to run. For the program store offset, give the location (in hex) where you wish the program to be stored in memory. This allows programs to be stored in a different location than they will execute.

The relocating loader allows you to give someone only the relocatable file while retaining the source code. Here are examples of the output generated using the relocating loader.

```
FILE NAME? "0:REL.REL.04AUG"
Z-PG OFFSET? 0
ABS OFFSET? 0
PGM EXE OFFSET? 7800
PGM STORE OFFSET? 7800
LOAD MAP:
Z = 0000-0000
A = 0000-06BB
E = 7800-7800
S = 7800-7800
```

For information on the MAE user group send a SASE to ASM/TED Users Group (ATUG), c/o Brent Anderson, 200 S. Century, Rantoul, IL 61866, (217) 893-4577.

Mr. Cochrane has a Master of Science in electrical and computer engineering. Most of his programming on the PET is in assembler using the MAE assembler. You may contact him at 1402 Sand Bar Ferry Rd., Beech Island, SC 29841.

**MICRO**

No. 60 - May 1983

# Richvale Telecommunications

10610 BAYVIEW (Bayview Plaza)  
 RICHMOND HILL, ONTARIO, CANADA L4C 3N8  
 (416) 884-4165

**\$185<sup>00</sup> Canadian**  
**\$149<sup>00</sup> U.S.**  
 PLUS CUSTOMS BROKERAGE,  
 HANDLING AND MAILING CHARGE.

Also available  
 for VIC 20

## C64-LINK<sup>®</sup> The Smart 64

RTC

RTC

Call or write  
 payments  
 by VISA,  
 MASTERCARD  
 or BANK  
 TRANSFER.  
 Mail orders  
 also by  
 certified  
 check, etc.

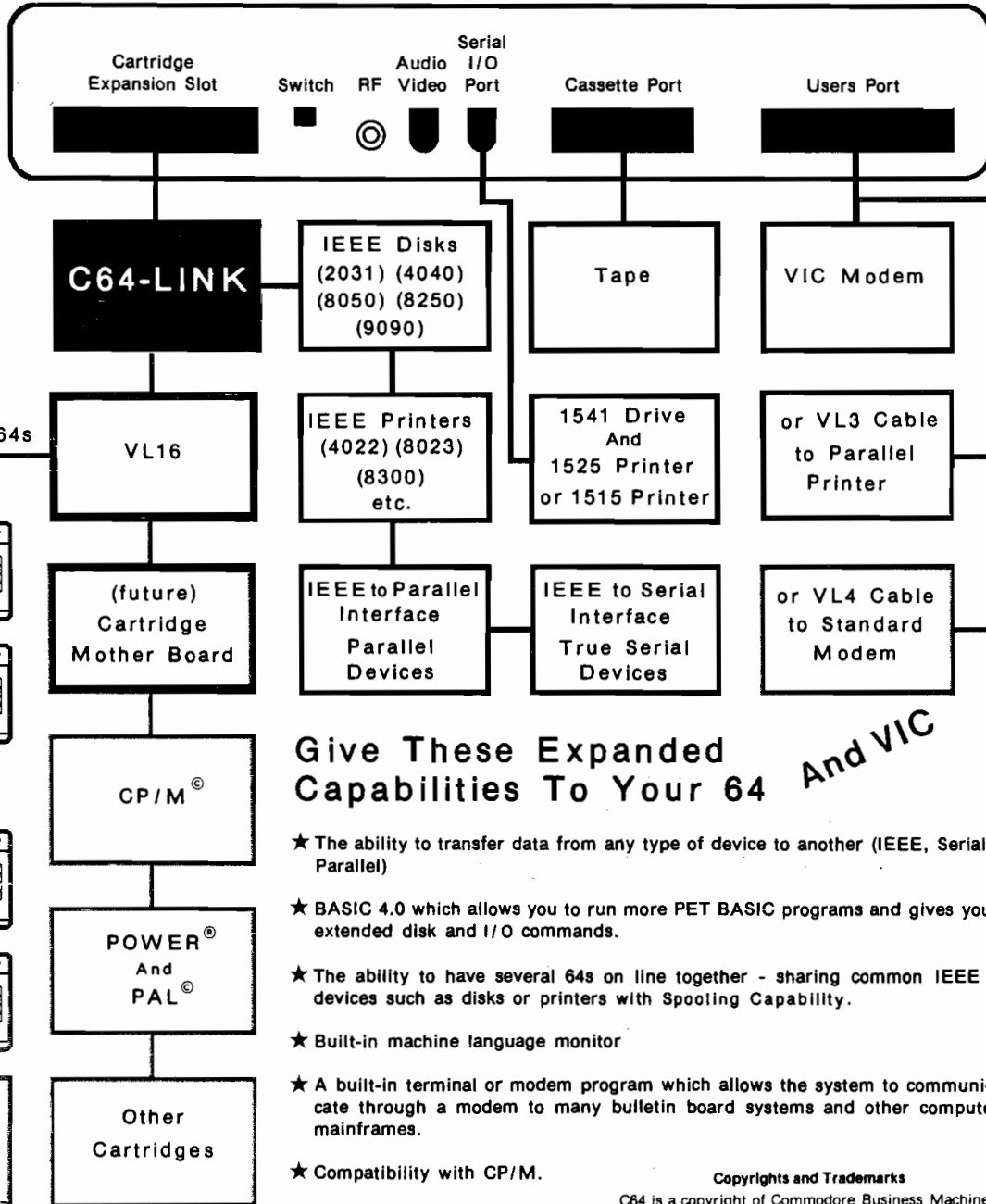

### Give These Expanded Capabilities To Your 64

And VIC

- ★ The ability to transfer data from any type of device to another (IEEE, Serial, Parallel)
- ★ BASIC 4.0 which allows you to run more PET BASIC programs and gives you extended disk and I/O commands.
- ★ The ability to have several 64s on line together - sharing common IEEE devices such as disks or printers with Spooling Capability.
- ★ Built-in machine language monitor
- ★ A built-in terminal or modem program which allows the system to communicate through a modem to many bulletin board systems and other computer mainframes.
- ★ Compatibility with CP/M.

**Copyrights and Trademarks**

C64 is a copyright of Commodore Business Machines, Inc. C64-LINK is a copyright of Richvale Telecommunications. CP/M is a registered trademark of Digital Research. POWER is a trademark of Professional Software. PAL is a copyright of Brad Templeton.

Contact your local Commodore dealer or RTC.

# 68000

# INSTRUCTIONS

by Joe Hootman

Perhaps some of the most fascinating instructions implemented by the 68000 are those classified as miscellaneous (see table 1).

Two trap instructions are available to the 68000 user. TRAP is a form of program control instruction; it loads the program counter with a particular vector and pushes the program counter and the status register onto the system stack. The TRAP instruction can select one of 16 trap vectors to be executed; any time the TRAP instruction is executed the machine will be vectored to the specified vector. The TRAPV instruction will perform in a similar manner to TRAP except that the V bit is checked; if it is set, the trap vector is fetched and executed. The TRAPV in-

struction is used extensively in two's complement arithmetic. When either of the TRAP instructions is executed, the processor goes into the exception processing state.

The Check Register Against Bounds (CHK) is used to compare the value in a register against a bound. The upper bound is expressed as a two's complement word-length integer located at the designated EA. The lower bound is zero. If the bound is exceeded, the CHK is selected and the processor goes into exception processing. This instruction allows the checking of array bounds by verifying that a data register contains a valid subscript. It is used extensively in higher-level languages such as Pascal.

Two special instructions are used to

call subroutines. These instructions are the link (LINK) and Unlink (UNLK) instructions. The link statement is used to reserve space on the stack to be used by a called subroutine. The LINK instruction pushes the designated register onto the stack. The updated stack pointer is then loaded into the designated register. The specified 16-bit sign-extended displacement is then added to the stack pointer. This allows the subroutine to access the data area on the stack by indexing off the designated register.

UNLK is used to return the reserved data area. LINK and UNLK can be used to maintain a linked list of local data and parameters on the stack for nested subroutines. Generally the LINK state-

Figure 1		Figure 2: Opword Field Using a Single EA.	
High Byte	Low Byte	Opword Field Using a Single EA	
Operation word (opword)	Even Address word number 1	15 14 13 12 11 10 9 8 7 6 5 4 3 2 1 0	Effective Address Mode Register
Immediate data/operand (if any)	Even Address + 2 word number 2	X X X X X X X X X X X	
Source Effective Address extension (if any)	Even Address + 4 word number 3	Figure 3	
Destination Effective Address extension (if any)	Even Address + 6 word number 4	Opword Format Using Two EAs	
16 bits wide		15 14 13 12 11 10 9 8 7 6 5 4 3 2 1 0	Effective Address Mode Register
		X X Size	Effective Address Mode Register

ment is used before the subroutine call and the UNLK is used just before the RTS at the end of the routine.

The NOP instruction just passes the control of the program to the next instruction.

### Addressing Modes

Six general addressing mode categories are available to the 68000 user. Variations of the general categories extend the total number of addressing modes to 14. The 14 address modes combined with the 56 basic instructions give a potential of 784 separate instructions. However, some of the instructions do not make use of all the addressing modes. The addressing modes that are implemented in the 68000 are listed below.

1. Direct Addressing Using Register
  - a. Data Register Direct
  - b. Address Register Direct
2. Direct Memory Addressing
  - a. Absolute Short
  - b. Absolute Long
3. Indirect Memory Addressing
  - a. Register Indirect
  - b. Post-increment Register Indirect
  - c. Pre-decrement Register Indirect
  - d. Register Indirect with Displacement
  - e. Register Indirect with Index and Displacement
4. Implied Register Addressing
5. Program Counter Relative Addressing
  - a. PC-relative with Displacement
  - b. PC-relative with Index and Displacement
6. Immediate Addressing
  - a. Immediate
  - b. Quick Immediate

The 68000 expects to find instructions in a prescribed sequence with the first 16-bit word being the operation word (opword). Every instruction must have an operation word; this word tells the processor what addressing mode is being used and how many extension words are associated with the instruction. Not every instruction needs to make use of the extension words. For example, the instructions that make use of implied addressing do not make use of the extension word.

The general format for the total instruction is given in figure 1.

A major difference between the 68000 and existing 8-bit processors is the way the 68000 accesses memory. The 68000 generally expects to fetch instructions from the memory on even addresses. If the address bus is forced to an odd address the processor will go

**Table 1: Miscellaneous Instructions**

Mnemonic	Data Size/CCR	Name	Comments
NOP	— CCR X N Z V C	No Operation	No operation occurs and execution continues with the next instruction.  Opword Format 15 14 13 12 11 10 9 8 7 6 5 4 3 2 1 0 0 1 0 0 1 1 1 0 0 1 1 1 0 0 0 1
TRAP	— CCR X N Z V C	Trap	This instruction forces the processor to one of 16 trap vectors. The processor will be put into the exception processing state.  Opword Format 15 14 13 12 11 10 9 8 7 6 5 4 3 2 1 0 0 1 0 0 1 1 1 0 0 1 0 0   Vector  The vector field specifies which trap vector contains the new program counter to be loaded.
TRAPV	— CCR X N Z V C	Trap on Overflow	This instruction initiates exception processing if the overflow condition is true. The new program counter is loaded from the TRAPV exception vector.  Opword Format 15 14 13 12 11 10 9 8 7 6 5 4 3 2 1 0 0 1 0 0 1 1 1 0 0 1 1 1 0 1 1 0
CHK	16 CCR X N Z V C — • U U U	Check Register Against end Bounds	This instruction compares a specified data register to an upper bound. The upper bound, a 16-bit two's complement integer, is exceeded then the processor picks up the CHK exception vector and enters exception processing.  Opword Format 15 14 13 12 11 10 9 8 7 6 5 4 3 2 1 0 0 1 0 0   Register   1 1 0   Effective Address Mode   Register  The field specifies the data register whose contents are to be checked. The effective address specifies the upper bound of the word to be checked against Dn. The following effective address modes cannot be used: 2, 13, 14.*
LINK	— CCR X N Z V C	Link and Allocate	The following steps are executed: 1. The contents of the specified address register are pushed onto the stack. 2. The address register is then loaded with the updated SP. 3. A 16-bit sign-extended offset is added to the SP.  Opword Format 15 14 13 12 11 10 9 8 7 6 5 4 3 2 1 0 0 1 0 0 1 1 1 0 0 1 0 1 0   Register Displacement  The register field specifies the address register through which the link is to be constructed; the displacement field specifies the two's complement integer that is to be added to the stack pointer.
UNLK	— CCR X N Z V C	Unlink	The stack pointer is loaded with the specified address register and the address register is loaded with the long word data from the top of the stack.  Opword Format 15 14 13 12 11 10 9 8 7 6 5 4 3 2 1 0 0 1 0 0 1 1 1 0 0 1 0 1 1   Register  The register field specifies the address through which the unlinking is to be done.

\* See next month's table.

# AIM + POWER

from

# COMPUTECH

All prices  
**Postpaid**  
 (Continental  
 U.S. —  
 otherwise  
 \$2 credit)

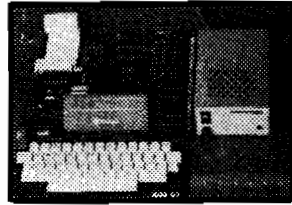

Check the  
**outstanding  
 documentation**  
 supplied with  
**AIM65**

**Top quality power supply** designed to Rockwell's specs for fully populated AIM 65 — includes overvoltage protection, transient suppression, metal case and power cable:

PSSBC-A (5V 2A Reg; 24V .5A Avg, 2.5A Peak, Unreg) ...**\$64.95**  
 Same but an extra AMP at 5 volts to drive your extra boards:  
 PSSBC-3 (5V 3A Reg; 24V .5A Avg, 2.5A Peak, unreg) ...**\$74.95**

The **professional's choice** in microcomputers:

AIM65/1K RAM .....**\$429.95** BASIC (2 ROMS) ..... **\$59.95**  
 AIM65/4K RAM .....**\$464.95** ASSEMBLER (1 ROM) .. **\$32.95**  
 FORTH (2 ROMS) .....**\$59.95**.

**SAVE EVEN MORE ON COMBINATIONS**

AIM65/1K + PSSBC-A **\$.479.95** AIM65/4K + PSSBC-3 **\$.524.95**

We gladly quote on all AIM65/40 and RM65 items as well.

**ORDERS: (714) 369-1084**



P.O. Box 20054 • Riverside, CA 92516  
 California residents add 6% sales tax

Circle No. 33

into exception processing. Exception processing will also occur if a word or long word operand fetch occurs on an odd address.

Most instructions make use of a single effective address (EA) in the operation word (opword) field. The format for the opword field is given in figure 2.

The Xs in the high order bits of the opword are encoded to indicate the type of operations to be performed. The EA defines the addressing mode, and if a single EA is used, the EA may be either a source or destination. The source is where the microprocessor will seek the data to be operated on, and the destination is where the data is stored after it has been operated on by the instruction.

The EA is made up of two parts — the mode and the register. The register number may be either a data register or an address register, depending on what is specified in the mode. The mode then specifies the type of addressing and register type to be used to implement the addressing mode. The coding of the opword for the various effective address (EA) modes can be coded by using the table provided next month. The single EA format is used for most of the opwords except for a few MOVE instructions. The move instructions that do not use the above format make use of two effective addresses in the opword. The format for these double EA is given in figure 3.

In addition to the effective address information in the opword, the size of the data or operand is specified if variable length data is permissible. The code for the "size" field is 00-byte (8 bits), 01-word (16 bits), 10-longword (32 bits).

To illustrate the addressing modes each mode will be discussed with an example. The MOVE instruction will be used for the examples as it is one of the most common instructions and uses all the addressing modes. The extension of the addressing modes to other instructions is relatively straightforward.

*Editor's note:* The second part of the discussion on Addressing Modes (including the table), will appear next month in MICRO.

Joe Hootman can be contacted at the University of North Dakota, Department of Electrical Engineering, University Station, Grand Forks, North Dakota 58202.

Circle No. 34

Circle No. 35

## COMPU SENSE

**CARDBOARD 6**  
**\$87.95**

An expansion interface for the VIC-20. Allows expansion to 40 K or accepts up to six games. May be daisy chained for more versatility.

**CARDBOARD 3**  
**\$39.95**

Economy expansion interface for the VIC-20

**CARD "?" CARD/PRINT**  
**\$79.95**

Universal Centronics Parallel Printer Interface for the VIC-20 or CBM-64. Use an Epson MX-80 or OKIDATA or TANDY or just about any other.

**CARDETTE**  
**\$39.95**

Use any standard cassette player/recorder with your VIC-20 or CBM-64

**LIGHT PEN**  
**\$29.95**

A light pen with six good programs to use with your VIC-20 or CBM-64

Prices subject to change.

TO ORDER: P. O. BOX 18765  
 WICHITA, KS 67218  
 (316) 263-1095

Personal Checks Accepted (Allow 3 Weeks)  
 or C.O.D. (Add \$2) Handling Charges \$2.00

## SYSTEMS INTEGRATOR

INTRODUCING:

**ZYTREX  
 ZT14411  
 CMOS BAUD RATE  
 GENERATOR**

REPLACES MOTOROLA MC14411

- PIN/FUNCTION COMPATIBLE
- IMPROVED FREQ OUTPUT DRIVE (4 LSTTL LOADS)
- FULLY STATIC OPERATION
- TTL-COMPATIBLE INPUTS
- WIDE OPERATING VOLTAGE

**FREE EVALUATION SAMPLES  
 FOR VOLUME USERS**

**\$6.20 EACH AT 1000 PCS.**

**ZYTREX CORPORATION  
 224 NORTH WOLFE ROAD  
 SUNNYVALE, CA 94086  
 (408) 733-3973**



# It's All Relative Part 5

by Jim Strasma

This part  
of the  
series  
explains how  
to format  
and print data  
from  
Comodore  
relative disk files.

**B**efore I begin this month, I have one correction for those without BASIC 4. In parts 2 and 3 of this series, (MICRO 56 and 57), I showed substitutes for BASIC 4 commands using the disk command channel: ie., OPEN 15,8,15:PRINT#15,"[command]":CLOSE 15. I suggested it would be better to open file 15 to the disk once in setup, and leave it open. Arthur Cochran reminds me that it's not only better — if you don't leave it open, CLOSE 15 closes all other disk files. BASIC 2 users should open file 15 at the start of the setup module and keep it open until ending the program in the menu module. Sorry for any inconvenience.

The obvious task neglected thus far is the one most people associate with a mail list — printing mailing labels. Although you now can create, find, display, and edit names and addresses with ease, you must be able to transfer those results to paper. For that reason a printer is one of the most useful devices to use with a computer, more important even than the disk drive. Let's put it to use.

## Preliminaries

There are two kinds of printers — Commodore's and everyone else's. They speak "PETSCII" and ASCII," respectively. As these names imply, their character sets are similar but not identical. Some interfaces automatically convert PETSCII to ASCII. Of these, some do so whether you like it or not, and others allow the conversion to be switched off. Try to get the switchable kind. Many programs do PETSCII to ASCII conversion internally and can do fancier things with ASCII printers if the interface doesn't undo their work.

Bennett's Mail List does PETSCII to ASCII conversions on request. This is set up in the first module of the program by the variable PZ\$. If it contains "a", conversion is done. If it contains "p", no conversion is done. If it contains "n", printing is to the screen only.

Although PZ\$ is selected in the first module, most of its work is done in the "4040 print" module (my present example). If the printer uses ASCII, line 1110 swaps the preset mnemonic fields from the setup module to keep printouts in the proper case. Also, if the output is to the screen instead of a printer, lines 1120 and 1130 set up proper vertical spacing, using variable C\$, which contains only a carriage return:

```
1110 IF PZ$ = Z"A" THEN WK$ = C1$:
      C1$ = C3$:C3$ = WK$:WK$ = C2$:
      C2$ = C4$:C4$ = WK$
1120 CR$ = " "
```

1130 IF PZ\$ = "N" THEN CLOSE 4:  
OPEN 4,DV:CR\$ = C\$

Notice that line 1130 first CLOSES then reOPENS file number 4. This is a good idea any time you are unsure whether or not the file is already open from use elsewhere in a program. When there is no printer, the program presets variable DV to 3, the device number of the screen. Thus, line 1130 essentially tells PET to use its own display screen as a printer. Then the user sees the first of several questions in a short menu:

```
1240 PRINT "PRINT THE MAILING LIST
BY:"
1250 PRINT "1 LAST NAME & INITIALS
1260 PRINT "2 POSTAL CODES
1270 PRINT "3 CODES
1280 PRINT "4 ALTERNATE KEY
1290 PRINT
1300 PRINT " (USE - 1 TO - 4
MEMBERS ONLY:)"
1310 MO = 0
1320 GOSUB 3470:REM GET
1130 IF WK$ = " - " THEN MO = 1:
GOSUB 3470:REM GET
```

These choices are not exhaustive; with small changes, other fields could be read instead of the postal code. However, the choices are effective as they are and include not only the usual alphabetical output by key (1), numeric by record number (4), and all-important zip code order, but also a powerful code option and a further option that pre-selects by code regardless of which other option is chosen — the " - " option. The latter was added when I needed to send out a financial drive letter using a mail list consisting of both church members and occasional visitors. Not wanting to offend visitors, I preset the program to eliminate all but member records from the printout. To keep the method general-purpose, it is set up in the start-up module, where the test column within the code field and its allowable "member" contents are selected. For my use, column 1 must contain either an "M" or a "C" to be considered a member.

One other preliminary chore is the actual reading of the key file. If this is a rerun of the module, the key file may already be in memory. If so, why read it again? Variable GD (Got Data) keeps track of this:

```
1370 IF SB = GD THEN DOPEN#1,
(F$),D(DD):GOTO 1420
1380 GOSUB 3220:REM READ KEY
FILE
1390 GD = 0
1400 IF SB < > 1 THEN GD = SB:REM
KEY READ
```

How the key file is read depends on the type selected. If the key is the primary or alternate key, its index file is read just as in the update module (MICRO 57:34). Otherwise, the selected field of data is read from each record into a new temporary index array that is retained in memory during the printout. This usually consumes more memory than reading an index file, so a calculation is made in lines 3790-3810 to limit the portion of the key that is stored in memory when it is necessary to conserve space:

```
3780 S2 = LE%(KF)
3790 WK = INT((FRE(0)-999)/NV)-2
3800 IF WK < 1 THEN WK = 1
3810 IF S2 > WK THEN S2 = WK
```

[C64 owners won't need to change line 3790. The program uses enough memory to keep it from reporting negative bytes free.]

Then line 3860 makes sure each key entry is the same length, using BL\$ (a string of blanks) as a spacer:

```
3860 : K$ = MID$(D1$(KF) + BL$,S1,S2)
```

**IT'S ALL RELATIVE**  
requires:

Any Commodore disk drive  
with DOS 2 or higher

Now it is necessary to insert the key entry in the key array being built in memory. The sort routine below is a variation of the binary search technique I used to locate a record (MICRO 57:33).

```
3870 : REM CALC POS
3880 : I = 1
3890 : J = V
3900 : IF I > J THEN 3960
3910 : K = INT((I + J + 1)/2)
3920 : IF K$ = KY$(K) THEN 3960
3930 : IF K$ < KY$(K) THEN J = K - 1:
GOTO 3900
3940 : I = K + 1
3950 : GOTO 3900
3960 : P = K
3970 : V = V + 1
3980 : REM INSERT KEY INTO ARRAY
3990 : P = P - 2
4000 : IF P < 1 THEN P = 1
4010 : IF V = 1 THEN KY$(1) = K$
:K%(1) = RR:GOTO 4130
4020 : FOR K = P TO V
4030 : : IF K$ < KY$(K) THEN
P = K:K = V
4040 : NEXT
4050 : IF K$ < KY$(P) THEN 4090
```

```
4060 : KY$(V) = K$
4070 : K%(V) = RR
4080 : GOT 4130
4090 : E = V
4100 : SYS DL,0,P,E,KY$(0),K%(0),ZZ
4110 : KY$(P) = K$
4120 : K%(P) = RR
4130 : IF V = NV THEN RR = NR
4140 NEXT
4150 RETURN
```

Line 4100 keeps the time delay for this sorting process within reason by moving all necessary entries up one space in the array to leave room for the current key. As shown before, this could be done in BASIC, but far more slowly (MICRO 55:34).

A second menu selection is offered after the key field has been read in. In this second menu, the possible printouts are listed:

```
1480 PRINT "0 = END
1490 PRINT "SELECT THE LISTING
TYPE
1500 PRINT "1 PRINT MAILING
LABELS
1510 PRINT "2 PRINT MAIL/PHONE
LABELS
1520 PRINT "3 PRINT COMPLETE
REPORT
1530 PRINT "4 PRINT TELEPHONE
LIST
1540 PRINT "5 PRINT VISITING LIST
1550 PRINT "6 DUMP OUTPUT TO
DISK
1560 PRINT "7 COUNT ONLY
1570 PRINT " (USE - 1 TO - 7 FOR
LOCALS ONLY)
1580 GOSUB 33470:REM GET
1590 IF WK$ = "0" THEN 2930
1600 LO = 0
1610 IF WK$ = " - " THEN LO = 1:
GOSUB 3470:REM LOCALS ONLY
```

As above, these options are not the only ones possible, but include all those needed in my two years of use. Most are variations of fields included in the printout. The disk option, however, is flexible. It allows any number of fields in any order to be sent to the disk as a sequential file. This allows the mail list to be used effectively with most popular word processors for form letters. It also eases the chore of restructuring data when sending it to another data-manager program.

The count-only option was added when I found myself wondering how selective to be in bulk mailings. In the U.S., non-profit bulk mailings must go to 200 persons to qualify for cut-rate postage. This option allowed me to try different selection criteria to see how many would qualify before wasting any mail labels

(Continued on page 67)

# OMEGA INTERNATIONAL

## SAVE ON ... COMPUTERS • MONITORS PRINTERS • PERIPHERALS • SUPPLIES\*



**OMEGA  
BLOCKBUSTER  
SPECIAL**

**AMDEK  
COLOR I MONITOR**

**\$289** Manufacturers  
Suggested  
Retail Price  
449.00

Offer Good Thru 5/31/83

### NEW! EPSON FX-80 PRINTER

Now Available  
For Immediate Delivery!

- Up To 160 cps • 11 x 9 Matrix • Pinfeed Platen
- Proportional Spacing • Graphics • Elite Pitch
- Centronics Parallel Interface • Internal 2K Ram

It's All New...And It's OMEGA PRICED!  
For Our Price...CALL 1-800-343-0873 TODAY!

#### SAVE ON LETTER QUALITY PRINTERS

DIABLO 620 New Low Price .....	<b>929.00</b>
DIABLO 630 w/API & cable .....	<b>1,749.00</b>
NEC 3510 SPINWRITER .....	<b>1,399.00</b>
NEC 7710 SPINWRITER .....	<b>2,045.00</b>
NEC 7730 SPINWRITER .....	<b>2,095.00</b>

#### BIG SAVINGS ON ACCESSORIES

HAYES SMARTMODEM 300 Baud .....	<b>230.00</b>
HAYES MICROMODEM II (APPLE II) .....	<b>289.00</b>
MICROSOFT SOFTCARD PREMIUM SYSTEM .....	<b>459.00</b>
ORANGE MICRO GRAPPLER + .....	<b>120.00</b>
PKASO PRINTER CARDS .....	<b>129.00</b>
RANA ELITE I (APPLE II) .....	<b>299.00</b>
SIGNALMAN MODEMS (MK I) As Low As ..	<b>85.00</b>

#### ACCESSORIES & SUPPLIES

OMEGA Has A Complete Line of Accessories & Supplies for the Apple II and many other Popular Computers by manufacturers like:

- D. C. Hayes • Microsoft • Tymac
- M & R Enterprises • Mountain Computers
- Kensington Microware • Practical Peripherals
- T.G. Products • Videx

#### SOFTWARE

Omega Carries Software by the following companies:

- American Business Systems • Ashton Tate
- Dakin 5 • Innovative Software • Microsoft
- Sorcim • Stoneware • Visicorp

#### MAGNETIC MEDIA

OMEGA Stocks Diskettes by:

- Dysan • Elephant • Maxell • Verbatim
- All Equipment Factory Fresh w/ MFT Warranty
- Prices Do Not Include Shipping Charges
- Mass. Residents Add 5% Sales Tax
- All Returns Subject To Restocking Fee

**CUSTOMER PICKUP NOW AVAILABLE**  
334 R Cambridge St., Burlington, Mass.  
(617) 229-6464

#### DOT MATRIX PRINTER BARGAINS

C-ITOH PROWRITER 8510 AP .....	<b>399.00</b>
IDS MICROPRISM 480 .....	<b>549.00</b>
OKIDATA MICROLINE 92 (NEW) .....	<b>549.00</b>
OKIDATA MICROLINE 93 (NEW) .....	<b>859.00</b>
STAR MICRONICS GEMINI 10 .....	<b>349.00</b>

#### MONITOR SPECIALS FROM OMEGA

AMDEK 300 G .....	<b>139.00</b>
AMDEK 300 A .....	<b>165.00</b>
NEC JB1260 .....	<b>119.00</b>
NEC JB1201 M .....	<b>169.00</b>
USI Pi-2 12" GREEN MONITOR .....	<b>159.00</b>
USI Pi-3 12" AMBER MONITOR .....	<b>179.00</b>



**CALL TOLL FREE!**  
**1-800-343-0873**  
Call Toll Free for Ordering.  
All Others call (617) 229-6464

**CHARGE IT!**  
MasterCard / Visa  
WELCOME AT NO  
EXTRA CHARGE

\* PRICES, SPECIFICATIONS AND AVAILABILITY OF ADVERTISED MERCHANDISE SUBJECT TO CHANGE WITHOUT NOTICE

UNADVERTISED SPECIALS ON • COMREX • EPSON • NEC • IDS PRISM • OKIDATA

# OMEGA INTERNATIONAL

334 R CAMBRIDGE STREET, BURLINGTON, MA. 01803

# AMDEK...your guide to

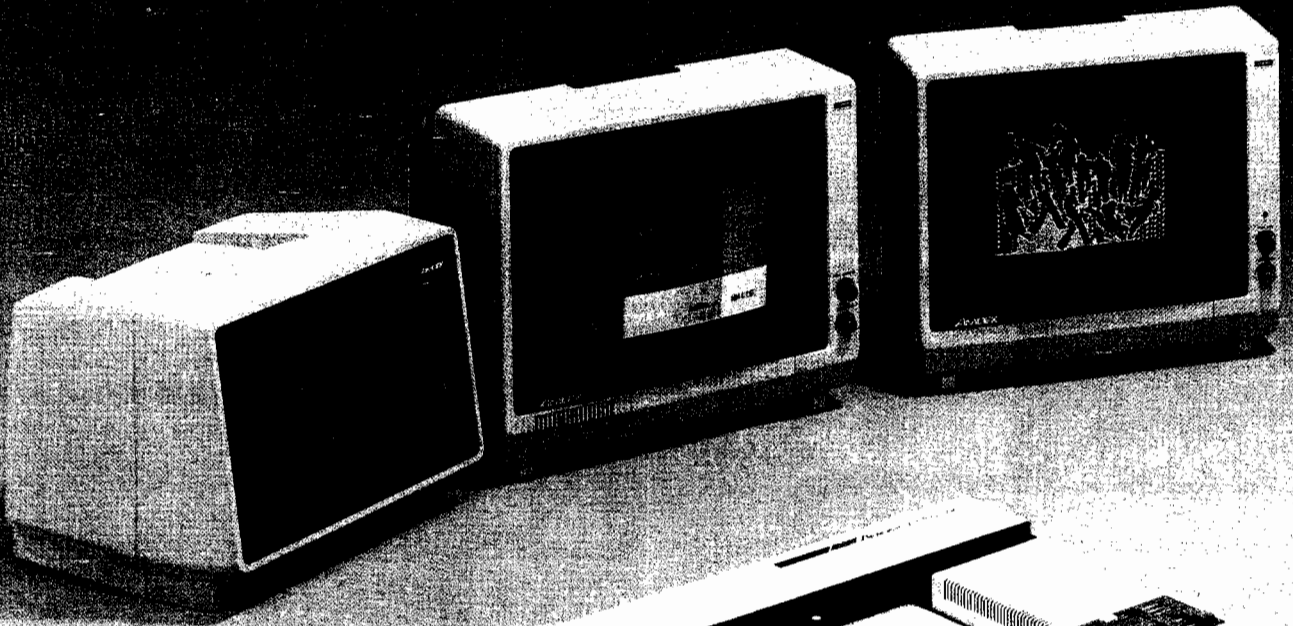

## MODEL DXY PLOTTER

Economical X-Y coordinate plotter • 10" X 14" plotting range • Centronics interface • ROM expandable • 4 pens, holders and chart hold-downs included

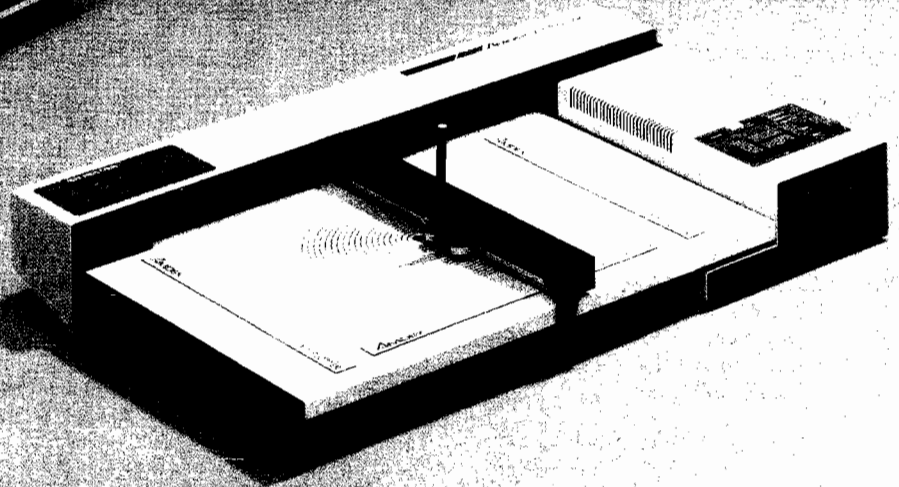

## YOUR COMPATIBILITY CHART

MORE COMPATIBILITY INTERFACES DUE SOON . . . CHECK FACTOR

COMPUTER	MONITORS							PLOTTER	3" MICRO-DISC DRIVE	NOTES
	VIDEO-300	VIDEO-310	COLOR-I	COLOR-II	COLOR-III	COLOR-III	COLOR-IV			
IBM-PC	•	•	•	•	*	•	*	•	•	* Special Cabling Required
APPLE III	•			*	*	*	*	•		* Special Cabling or Converter Required
APPLE II	•		•	*	*	*	*	•		* DVM Board Required
ATARI 800	*		*							* Opt. Atari Cable Required
VIC-20			*							* Opt. VIC Cable Required
TRS-80	*									* Opt. TRS Cable Required
Osborne	*									* Opt. Interface Required
TI-99			*							* Opt. TI Cable Required
Commodore-64	*		*							* Opt. Commodore Cable Req.

# innovative computing!

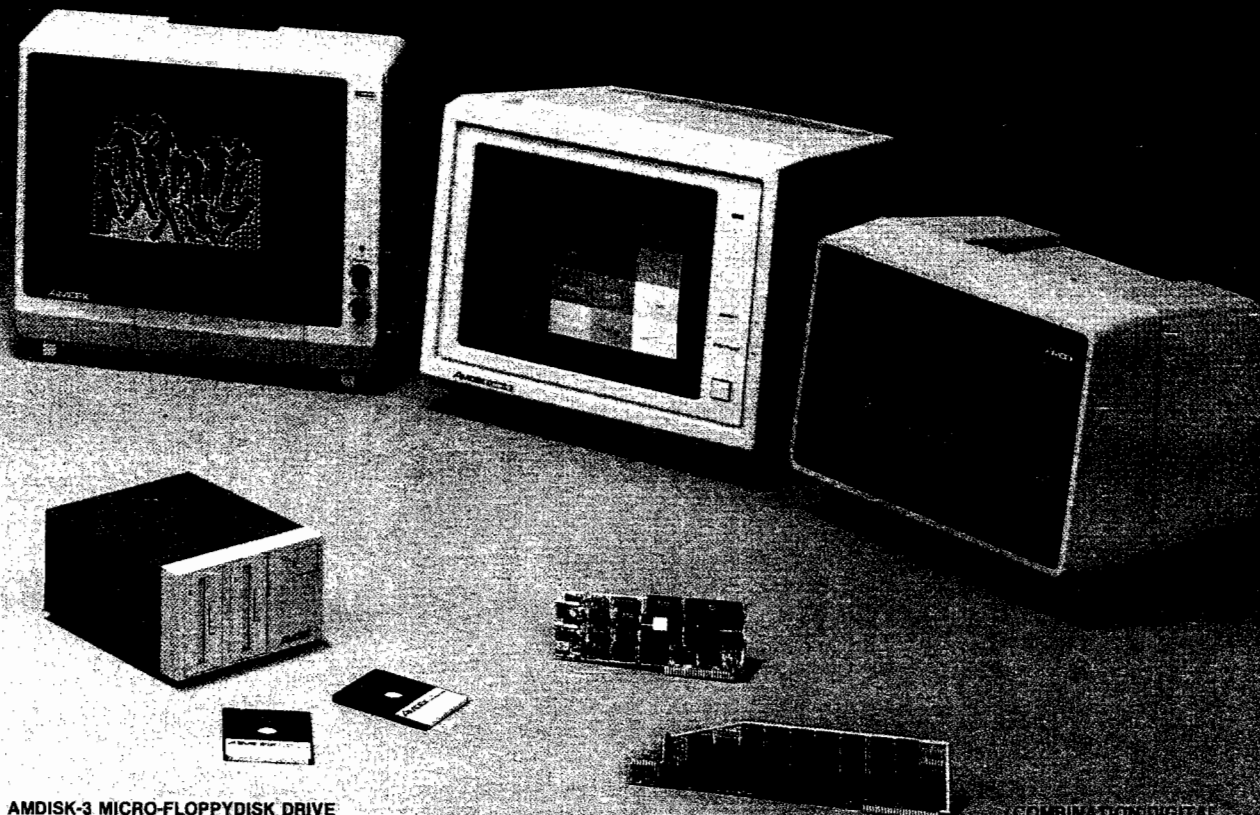

## AMDISK-3 MICRO-FLOPPYDISK DRIVE

Revolutionary 3" Micro-Floppydisk drive & cartridges • 1 Megabyte (unformatted) storage • Track-to-track compatible with 5 1/4" floppydisk drives • Built-in power supply • Hard plastic, protective floppydisk cartridge

## COMBINATION DIGITAL VIDEO MULTIPLEXER

Makes Apple II compatible with high monitors • Modes include Apple II character, line, font, Apple high/low resolution, color graphics • 300 character lines (not from vertical board included)

Amdek Corp. is dedicated to marketing quality computer peripheral equipment to enhance the use of popular personal computers. Our research & development staff keeps abreast of progress in computer technology and equipment and strives to offer you state-of-the-art advances in peripheral equipment.

Amdek products are distributed nationwide and in Canada through major distributors. And, we have factory-trained manufacturer's representatives ready to serve you in every major marketing area. Amdek offices are located in Chicago, Los Angeles & Dallas.

Just circle the reader service number, or contact us to receive complete technical specifications on these Amdek products.

2201 Lively Blvd. • Elk Grove Village, IL 60007  
(312) 364-1180 TLX: 25-4786

# AMDEK CORP.

# EVERYONE NEEDS A...

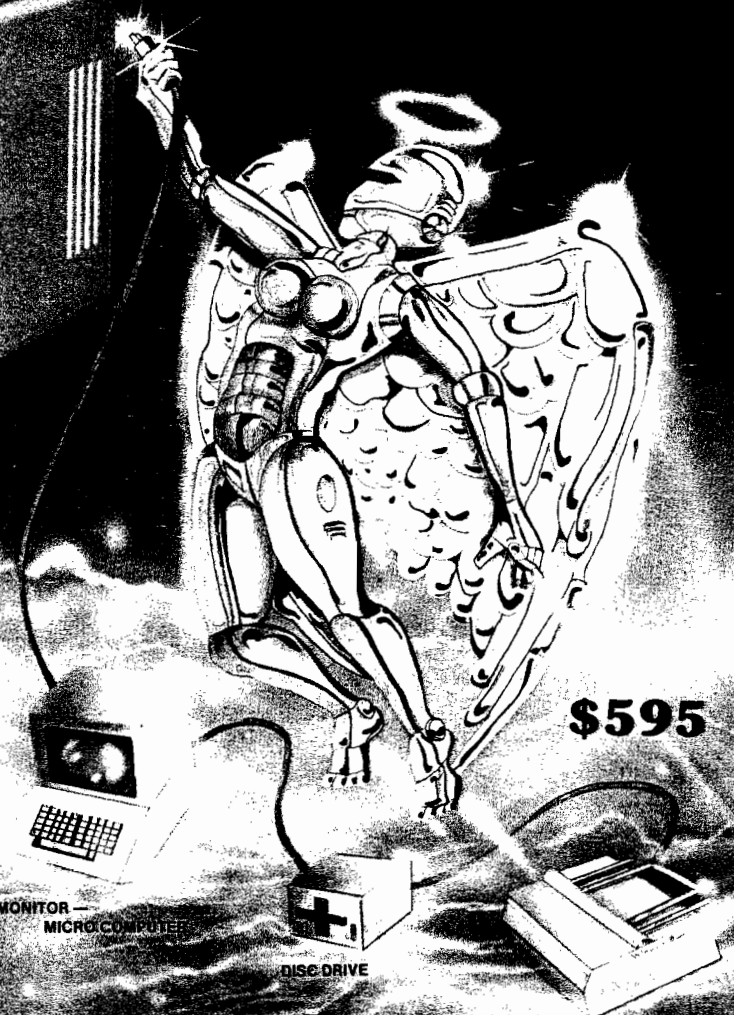

**\$595**

- A**UTOMATIC SOURCE
- A**DVANCED DESIGN
- N**EW RELIABILITY
- G**UARDIAN PROTECTS
- E**LECTRONIC SAFETY
- E**SSAYER FOR DATA

**SAVE YOUR DATA FROM POWER OUTAGES**

**BACKUP YOUR DATA FROM POWER OUTAGES**

- Automatically shuts down your system when power is lost
- Maintenance free lead acid battery - available in 12 volt or 24 volt - provides 6 minutes of standby power to save your system from a 12 volt source
- Automatic surge protection - protects your system from power line surges
- Automatic battery status indicator - tells you when the battery is low
- No voiding warranty - no cutting wires
- Automatic shut down - no damage to your data or hardware
- UL listed • FCC approved • Transient voltage suppressor - protects your system from line voltage spikes, utilizing Zener Ray™
- Green/red LED power status indicator • Green - normal AC line power • Slow blinking red - at least 6 minutes of remaining standby power • Fast blinking red - approximately 2 minutes of remaining battery power • Solid state technology unexcelled by any UPS power unit in its class.

**RH ELECTRONICS, INC.**

COPYRIGHT © 1981 - PATENTS PENDING  
566 IRELAN, BUELLTON, CA 93427  
(805) 688-2047

**SEE YOUR RH ELECTRONICS PRODUCTS DEALER**

**FOR YOUR APPLE II\*:**

SUPER FAN II™	\$ 74.95
SUPER FAN II™/ZENER RAY™	\$109.00
SUPER RAM II™	\$125.00
RH 12 VOLT TRANSVERTER	\$149.00

**FOR MICRO COMPUTERS:**

GUARDIAN ANGEL™	\$595.00
-----------------	----------

Each option requires a bit of added setup at this point. Variable PT\$ is set to the type of printout wanted. The code used lets "s" stand for a summary, "l" for label, "o" for output to disk, and so on. Notice that additional variables are set for some options. For example, ZT = 1 when you want a mail label plus phone number. This eliminates needing an extra routine to format it.

```
1360 IF SB = 3 THEN GOSUB 3540:
  REM SELECT CODE
1660 IF WK$ = "2" THEN PT$ = "L":
  ZT = 1
1670 IF WK$ = "4" THEN PT$ = "P"
1680 IF WK$ = "5" THEN PT$ = "V"
1690 IF WK$ = "6" THEN PT$ = "O":
  NU = 1:GOTO 1800
1700 IF WK$ = "7" THEN PT$ = "N":
  NU = 1:GOTO 1800
1710 IF PZ$ = "N" THEN NU = 1:FL = 1:
  GOTO 1800
```

The following section selects 1-up, 2-up, or 3-up output to match various paper sizes. One-up is preset in variable NU by options that require it.

Another common problem when printing mail labels is the printout that goes haywire halfway through. Bennett's Mail List offers some helps for this as you will see, provided you notice in time. If you don't notice until everything is done, you can re-run the print option and start the output from any point within the data. The program will ask "Start Printing from Beginning [y/n]." If you want to start somewhere else answer "n" and give the record number you want to use as a starting point.

If you have used an Addressograph™ to print mail labels, you may have noticed metal flags stuck to the edge of its printing plates. These allow the user to select certain labels from a group. Bennett's Mail List also allows this. It has 20 flags, each a character in the code field of the relative data file. These are more powerful than their Addressograph counterparts in that Bennett's flags may contain any alphabetic character. With careful selection of characters, one position may serve to order a large organization.

Because the code option is so important, it receives special handling in the print module setup. Regardless of other options already selected, the user also may select by code. Within the selected code position(s), 10 matches may be specified. There is also a "wild card" match-all option, which accepts

anything other than a blank as a match. The wild-card character, normally "z", is set by the contents of MA\$ in the startup module.

```
2080 PRINT "TO MATCH ALL NON-
  BLANKS, SELECT "MA$
2090 PRINT "OTHERWISE, LIST 1-10
  DESIRED MATCHES
2100 PRINT "NOW. THEN HIT [RETURN]
  ALONE
2110 FOR I = 1 TO 10
2120 : PRINT LEFT$(PO$,KL + I)
  "FIELD: ";
2130 : SYS IN,27,S2,L$
2140 : IF L$ = " " THEN CF = I - 1:
  I = 10
2150 : IF L$ = " " THEN I = I - 1:
  IF I = 0 THEN I = I - 1
2160 : CF$(I) = LEFT$(L$ + "□□□□
  □□□□□□□□□□□□
  □□□",S2)
2170 NEXT
```

The ↑ key backs up if an incorrect match character is selected.

Unless labels are to be printed, this completes the setup process. For labels, one more question is asked: "Print a Dummy Label [y/n]". If the answer is "y", a sample label is printed and the question asked again. This allows the user to align the labels in the printer.

```
2180 IF PT$ < > "L" THEN 2330
2190 Z$ = " "
2200 FOR I = 1 TO NU
2210 : Z$ = Z$ + "XXXXXXXXXXXXXXXXXXXX
  XXXXXXXXXXXXXXXXXXXX "
2220 NEXT
2230 GOSUB 3510:REM TITLE
2240 PRINT "PRINT A DUMMY LABEL
  (Y/N)
2250 GOSUB 3470:REM GET
2260 IF WK$ < > "N" AND WK$
  "Y" THEN 2230
2270 IF WK$ = "N" THEN 2330
2280 FOR I = 1 TO 5
2290 : PRINT#4,Z$
2300 NEXT
2310 PRINT#4
2320 GOTO 2230
```

Z\$ if concatenated to itself in lines 2200-2220 to make wider sample data for 2-up and 3-up printouts.

### Printing

The main loop of the printout is from lines 2340-2630. It reads each record, sees if it matches code criteria and whether or not it fits "member only" and "local only" options. After all this, the record is printed via a

GOSUB set in PT\$. When all full-width lines have been completed, one more pass is made to do any less-than-full-width lines that remain; i.e., one last label in a 3-up output}.

```
2340 FOR I = SN TO NV
...
2400 : GOSUB 4960:REM CHECK CODE
2410 : IF RC > 0 THEN 2450:
  REM FLUNKED CODE
2420 : IF MO = 0 THEN 2470: REM
  NOT FOR MEMBERS ONLY
2430 : WK$ = LEFT$(D1$(UC*NF),1)
2440 : IF WK$ = MM$ OR WK$ = MC$
  OR WK$ = MD$ THEN 2470
2450 : UC = UC - 1
2460 : GOTO 2630:REM SKIP NON-
  LOCALS
2470 : IF LO = 0 THEN 2520:REM NOT
  FOR LOCALS ONLY
2480 : WK$ = MID$(D1$(UC*NF),LP,1)
2490 : IF WK$ > = LL$ AND
  WK$ < = LH$ THEN 2520:
  REM LOCAL
2500 : UC = UC - 1
2510 : GOTO 2630: REM SKIP
...
2550 : TN = TN + NU
2560 : IF PT$ = "S" THEN GOSUB
  4170:UC = 0:REM SUMMARY
2570 : IF PT$ = "L" THEN GOSUB
  4520:UC = 0:REM LABELS
2580 : IF PT$ = "P" THEN GOSUB
  4690:UC = 0:REM PHONE LIST
2590 : IF PT$ = "V" THEN GOSUB
  4830:UC = 0:REM VISIT LIST
2600 : IF PT$ = "O" THEN GOSUB
  5110:UC = 0:REM SEQ. OUTPUT
2610 : IF PT$ = "N" THEN UC = 0
2620 : GET WK$:IF WK$ > " " OR
  FL THEN GOSUB 2780:REM
  PRINTER STATUS
2630 NEXT I
```

Variable TN keeps track of the total number printed thus far, adding NU, the number of labels in each row, to the total after each pass through the loop.

If a key is pressed during printing, or variable FL is non-zero, line 2620 branches to a subroutine that offers further options. After printing the record number(s) last printed, it waits for another key to be pressed. If that is a ← key, FL is set to halt the printer after each label, which is useful for cut sheets, loose cards, and individual envelopes. If the ↑ key is hit, FL is reset to restore non-stop printing. If the home key is hit, the printout is aborted safely by setting the record counter to the last record in the file.

```
2780 SW = I - NU
2790 IF PZ$ < > "N" THEN GOSUB
```

```

3510:REM TITLE
2800 PRINT "RECORD(S) LAST PRINTED
2810 FOR WK = 1 TO NU
2820 : PRINT "□□□□"SW + WK;
2830 NEXT
2840 PRINT
2850 PRINT "PRESS ANY KEY TO
CONTINUE
2860 GOSUB 3470:REM GET A KEY
2870 IF WK$ = " ← " THEN FL = 1:
REM FAST LIST OFF
2880 IF WK$ = " ↑ " THEN FL = 0:
REM FAST LIST ON
2890 I = SW + NU
2900 IF WK$ = "[home]" THEN I = NV:
REM ABORT
2910 RETURN

```

Lines 2780 and 2890 adjust the current record count to allow the currently printed record numbers to be displayed.

This completes my discussion of the print module. Now I will take a detailed look at how a mail label is formatted and printed.

The output example is the common mail label and illustrates a way to preserve order in printouts whether one, two, or three labels wide. As mentioned above, it does double-duty, printing either straight mail labels or mail and phone number labels, depending on the contents of variable ZT (Zip Telephone).

The actual relative file data to be printed is read into the D1\$( ) array by other routines similar to those studied in the update module (MICRO 58:85).

Here is the first part of the label routine:

```

4510 REM ** PRINT LABELS **
4520 IF ZT = 0 THEN 4570:REM
NO PHONE OPTION
4530 D1$(4) = D1$(4) + " " + D1$(PC)
4540 D1$(PC) = D1$(PH)

```

If ZT is non-zero in lines 4520-4540, the contents of the postal code field [PC] are appended to the contents of the last address field, and the phone field [PH] then takes the place of the postal code in the label. The same is done for a second and/or third record if more than one is to be printed at once.

```

4550 IFUC > 1 THEN D1$(4 + NF) =
D1$(4 + NF) + " " + D1$
(PC + NF):D1$(PC + NF) = D1$
(PH + NF)
4560 IFUC > 2 THEN D1$(4 + 2*Nf) =
D1$(4 + 2*Nf) + " " + D1$
(PC + 2*Nf):D1$(PC + 2*Nf) =
D1$(PH + 2*Nf)

```

The D1\$( ) array can hold three records at once, using NF (Number of Fields per record) as a step value between related elements of different records. This is more clearly seen in the actual printing routine:

```

4570 FOR II = 1 TO 5
4580 : FOR JJ = II TO II + UC*Nf-Nf
STEP NF

```

Variable II counts the current line on the label, and JJ offsets to the current record horizontally. Since all fields of up to three records are part of the same array, JJ takes its value from II, offset by NF.

Outputs to CBM printers begin with a cursor down key contained in DN\$.

```

4590 : IF PZ$ = "P" THEN PRINT#4,
DN$;

```

Outputs to ASCII printers begin with a SYS call that converts PETSCII to ASCII.

```

4600 : IF PZ$ = "A" THEN SYS SM,
1,D1$(JJ)

```

Line 4610 prints the field:

```

4610 : PRINT#4,D1$(JJ)LEFT$(BL$,
LW-LEN(D1$(JJ)) );

```

After the field data is printed, blanks are printed to move the print head to the proper place for the same field of the next record to be printed. This is what allows the multi-column printouts.

Since each field printout ends with a semi-colon (";"), an extra PRINT statement ends the line after the JJ loop, and another adds the blank line between labels after the II loop.

If the user has requested the index card option (IC = 1) during setup, line 4660 adds extra lines between labels to move to the same spot on the next card:

```

4660 IF NU = 1 AND IC = 1 THEN FOR
I1 = 1 TO 18:PRINT#4:NEXT

```

The other printout routines operate similarly and are largely copies of the above. Those in need of other special reports may add them as subroutines called from the main print loop beginning in line 2340.

One other routine in the print module is worthy of note. It serves two functions: first it expands Canadian postal codes to include a space after the first three characters at print time. (This same approach could be used

with U.S. nine-digit zip codes and with telephone numbers.) It saves space on the disk, but takes longer to format for printing.

```

4970 P = UC*Nf - (Nf-PC)
4980 CD$ = D1$(P) + " "
4990 AA = ASC(CD$)
5000 IF AA > 47 AND AA < 58
THEN 5020
5010 D1$(P) = LEFT$(CD$,3) + " " +
MID$(CD$,4,3)

```

Line 4970 locates the postal code field of the current record. The next three lines determine whether or not the postal code is Canadian, assuming it will be if the third character is not a number. Then line 5010 does the actual insertion of the added space.

The second purpose of this routine is to see whether or not the current record meets any code match criteria that have been established. When CF is non-zero, a code search is made of each of the CF possible code field matches to see if any fit the current record. When either no code is wanted, or the right code is found, variable RC is cleared to zero; otherwise it is set to one and the calling routine will skip that record on printouts.

```

4960 RC = 1

```

```

...
5020 IF CF = 0 THEN RC = 0:GOTO 5090
5030 P = UC*Nf
5040 FOR I2 = 1 TO CF
5050 : IF CF$(I2) = MID$(D1$(P)
+ " " ,S1,S2) THEN RC = 0
5050 : IF CF$(I2) = MID$(D1$(P)
+ " " ,S1,S2) THEN RC = 0
5060 : IF I2 > 1 OR CF$(1) < >
MA$ THEN 5080
5070 : IF MID$(D1$(P) + "□□□□□□
□□□□□□□□□□□□
□ □ ' '
,S1,S2) > B5$ THEN RC = 0
5080 NEXT
5090 RETURN

```

Variable MA\$ in line 5060 is the match-all character.

In the next and final installment of this series I'll describe the machine-language routines. Included will be a full source listing that will assemble for the PET, VIC-20, or Commodore 64. Conversion of the routines for the C64 has taken a little longer than expected, so the final installment will appear in the August issue.

Jim Strasma is assistant professor of computer science at Lincoln College. You may contact him at 1280 Richland Ave., Lincoln, IL 62656.

**MICRO**



# Products for Commodore, Atari, Apple, and others!

## NEW THE MONKEY WRENCH II A PROGRAMMERS AID FOR ATARI 800 NEW AND IMPROVED — 18 COMMANDS PLUGS INTO RIGHT CARTRIDGE SLOT

If you are a person who likes to monkey around with the ATARI 800, then THE MONKEY WRENCH II is for you!! Make your programming tasks easier, less time-consuming and more fun. Why spend extra hours working on a BASIC program when the MONKEY WRENCH can do it for you in seconds. It can also make backup copies of boot type cassette programs. Plugs into the right slot and works with ATARI BASIC cartridge.

The MONKEY WRENCH provides 18 direct mode commands. They are: AUTO LINE NUMBERING — Provides new line numbers when entering BASIC program lines. RENUMBER — Renumbers BASIC's line numbers including internal references. DELETE LINE NUMBERS — Removes a range BASIC line numbers.

VARIABLES — Display all BASIC variables and their current value. Scrolling — Use the START & SELECT keys to display BASIC lines automatically. Scroll up or down BASIC program. FIND STRING — Find every occurrence of a string. XCHANGE STRING — Find every occurrence of a string and replace it with another string. MOVE LINES — Move lines from one part of program to another part of program. COPY LINES — Copy lines from one part of program to another part of program. FORMATTED LIST — Print BASIC program in special line format and automatic page numbering. DISK DIRECTORY — Display Disk Directory. CHANGE MARGINS — Provides the capability to easily change the screen margins. MEMORY TEST — Provides the capability to test RAM memory. CURSOR EXCHANGE — Allows usage of the cursor keys without holding down the CTRL key. UPPER CASE LOCK — Keeps the computer in the upper case character set. HEX CONVERSION — Converts a hexadecimal number to a decimal number. DECIMAL CONVERSION — Converts a decimal number to a hexadecimal number. MONITOR — Enter the machine language monitor.

In addition to the BASIC commands, the Monkey Wrench also contains a machine language monitor with 16 commands used to interact with the powerful features of the 6502 microprocessor.



\$59.95

## NEW VIC RABBIT CARTRIDGE AND CBM 64 RABBIT CARTRIDGE

"High-Speed  
Cassette  
Load and Save!"

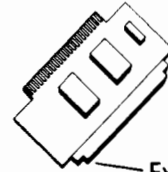

\$39.95  
(includes Cartridge  
and Manual)

Expansion Connector  
on the VIC Cartridge

"Don't waste your Life away waiting to LOAD and SAVE programs on Cassete Deck."

Load or Save 8K in approximately 30 seconds! Try it — your Un-Rabbitized VIC takes almost 3 minutes. It's not only Fast but VERY RELIABLE.

Almost as fast as VIC Disk Drive! Don't be foolish — Why buy the disk when you can get the VIC Rabbit for much, much less!

Easy to install — it just plugs in.  
Expansion Connector on rear.

Works with or without Expansion Memory.  
Works with VIC Cassete Deck.

12 Commands provide other neat features.

Also Available for 2001, 4001, and 8032

## Now for the "64" STCP — 300/1200 Baud Standard Terminal Communications Package

\*PFO\* IOD OOA CP<D1>D2 BELL = 12:30:00 10:14:36

Don't settle for non-standard Communications Protocol! Access Micro Net, Source, Bulletin Boards, Local Mainframe, etc.



- Complete Package — Includes RS232 interface Board and software (does not include modem)
- Communicates in Industry Standard ASCII
- Upload/Download to/from Disk
- Automatic File Translation
- Can be controlled from keyboard or user supplied basic or machine language program

Specify 3.0 or 4.0 ROMS or 8032 Commodore Computer 4040 or 8050 or PEDISK II Disk or CBM64 on 1541.

Price: \$129.95

## ATARI AND PET EPROM PROGRAMMER

Programs 2716 and 2532 EPROMs. Includes hardware and software. PET = \$75.00 — ATARI (includes sophisticated machine language monitor) = \$119.95

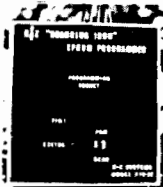

Prowriter Printer - Excellent dot matrix print Parallel = \$489 00  
Serial = \$600 00 IEEE = \$589 00

## PET BASIC SCROLL PROGRAM

Scroll thru Basic Programs using cursor up/down keys. Specify computer. \$6.00 on cassette, \$9.00 on diskette.

### 65C02 MAE

Same as our MAE but enhanced for the new 65C02 Opcodes. Turns your computer into a development system for the new ROCKWELL 65C02 Microprocessor. \$200.00 — Specify Computer.

### 6800 CROSS ASSEMBLER

A Cross Assembler based on the MAE that runs on the PET, Apple, or Atari but assembles opcodes for the Motorola 6800 microprocessor. Turns your computer into a development system for the Motorola 6800 Microprocessor. \$200.00 — Specify Computer.

### ATARI and VIC Cartridges

EHS can supply large quantities of ATARI and VIC Cartridges for software developers. If you need cartridges, call for pricing.

### TRAP 65

TRAP 65 is a hardware device that plugs into your 6502's socket. Prevents execution of unimplemented opcodes and provides capability to extend the machines' instruction set. For PET/APPLE/SYM. Reduced from \$149.95 to \$69.95



## More than just an Assembler/Editor! Now for the "64"

It's a  
Professionally  
Designed  
Software  
Development  
System

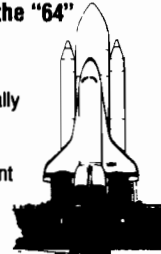

**MAE**  
for  
PET  
APPLE  
ATARI  
~~\$169.95~~  
New  
Price  
\$99.95

Blast off with the software used on the space shuttle project!

- Designed to improve Programmer Productivity
- Similar syntax and commands — No need to relearn peculiar syntaxes and commands when you go from PET to APPLE to ATARI.
- Coresident Assembler/Editor — No need to load the Editor then the Assembler then the Editor, etc.
- Also includes Word Processor, Relocating Loader, and much more.
- Options: EPROM Programmer, unimplemented opcode circuitry.
- STILL NOT CONVINCED? Send for free spec sheet!

## 5 1/4 INCH SOFT SECTORED DISKETTES

Highest quality. We use them on our PETs, APPLES, ATARIs, and other computers. \$22.50/10 or \$44.50/20



EPROMS 2716 = \$4.50 2532 = \$7.50  
Over 40 Commodore Programs by Baker (on 4040) = \$25.00

DC Hayes Smart Modem = \$235 00  
DC Hayes Micro Modem II = \$289 00

Rana Disk Drive - 375  
4 Drive Controller - 114

# Eastern House

3239 Linda Dr.  
Winston-Salem, N.C. 27106  
(919) 924-2889 (919) 748-8446  
Send for free catalog!



Circle No. 41

Design & Illustration: Paul Stephenson



# ADVENTURE. THE KEY IS YOUR COMPUTER

## ADVENTURE PACK I

(3 programs)

**Jack and the Beanstalk** Defeat the Giant in your quest for his Golden Hen.

**Computer Adventure** Re-live the "excitement" of getting your computer. An adventure with a very different flavor.

**Moon Base Alpha** You must find a way to destroy the meteor that is racing towards your base, or else all moon colonies will be demolished!

Available for VIC-20 and COMMODORE 64  
PLAYED WITH KEYBOARD

\$19.95

## ADVENTURE PACK II

(3 programs)

**African Escape** As the sole survivor of a plane crash, you must find your way out of the dark continent.

**Hospital Adventure** You are a spy whose mission is to complete the bungled assassination attempt on the evil dictator, who is recuperating in the hospital under heavy guard.

**Bomb Threat** Get back to town to warn the authorities of the bomb planted by the terrorists who left you prisoner at their hideout.

Available for VIC 20 and COMMODORE 64  
PLAYED WITH KEYBOARD

\$19.95

## KONGO KONG

Climb ladders, avoid the barrels the crazy ape is rolling at you, and rescue the damsel. Fast machine code action.

Available for VIC-20 and COMMODORE 64  
PLAYED WITH JOYSTICK OR KEYBOARD

\$19.95



## GRAVE ROBBERS

Introducing the first GRAPHIC ADVENTURE ever available on the VIC-20! With realistic audio-visual effects, you explore an old deserted graveyard and actually see the perils that lie beyond.

Available for VIC-20 and COMMODORE 64  
PLAYED WITH KEYBOARD

\$14.95



## ANNIHILATOR

Defend your planet against the hostile aliens. All machine code makes this "Defender-like" program one of our best arcade games.

Available for VIC-20 and COMMODORE 64  
PLAYED WITH JOYSTICK

\$19.95



## CHOMPER MAN

High speed machine action. Don't let the bullets catch you in a game packed full of machine code.

Available for COMMODORE 64  
PLAYED WITH JOYSTICK OR KEYBOARD

\$19.95

Programs for the  
VIC-20 and the  
COMMODORE

# VICTORY

SOFTWARE

VICTORY SOFTWARE INC.  
7 Valley Brook Road, Paoli, PA 19304  
(215) 296-3787

Check your local dealer or order directly.  
**ORDERING** We accept personal checks, money orders, VISA, and MASTER-CHARGE. Charge orders please include number and expiration date. Overseas orders please use charge or have check payable through a U.S. bank. Add \$1.50 postage and handling per order. PA residents please add 6% sales tax.



# The

# MICRO™

# LEARNING CENTER

Atari 800

Texas Instrument

## Features:



- **Breakup for the VIC-20**  
by Loren Wright and Phil Daley  
A simple animation demonstration of PEEKing and POKEing screen memory.
- **Addressfile**  
by Brian Zupke  
A file management system for the VIC-20 and other Commodore computers

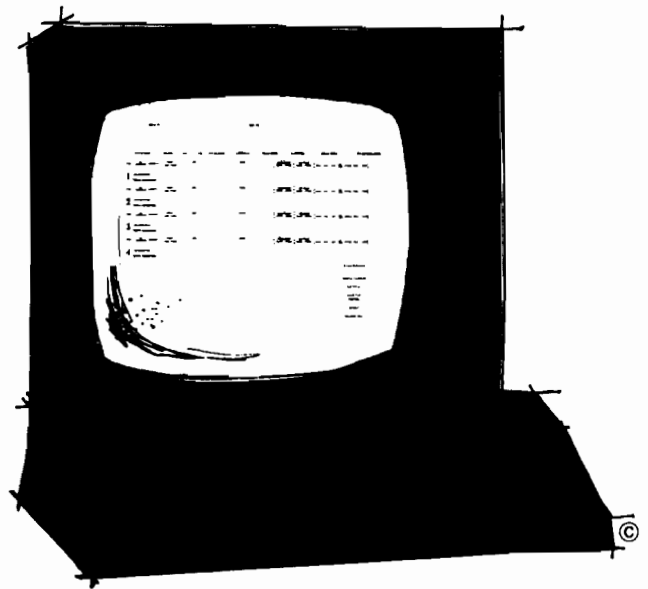

# HAVE YOU FLOWN YOUR ATARI TODAY?

## FINAL FLIGHT!

Imagine yourself at the controls of a small, single-engine plane, 10,000 feet in the air, on your approach to the runway and safety. You're running low on fuel, but your instruments show that you're on the glide path, and lined up with the runway. It's a beautiful, sunny day, and you can see the airport in the distance, across the grassy fields. But the crosswind is tricky, and it will take all your skill to land safely. You're coming down now, and the runway is getting closer. A bit left, OK, now lower the power, fine, now put down the flaps. Pull the nose up a bit more, you're a little low. Watch the power! Don't stall. OK. Here comes the runway. You hear the squeal of tires on



pavement, your pulse quickens, you're down, but watch it, you're pulling right! Brakes, brakes! Left more! You've stopped safely! Good job. The first real-time flight simulator for ATARI is now available from MMG Micro Software. Written entirely in machine language, there are four levels of difficulty, landings in clear or foggy weather, landings with or without instruments, and with or without the real-time view from the cockpit. **Final Flight!** requires Atari 400/800, 24K, 1 joy stick, and is offered on tape or disk for the same suggested retail price of \$29.95.



Circle No. 38

MMG

### Final Flight

is available at your local dealer or direct from **MMG Micro Software**. Just send check or money order to P.O. Box 131, Marlboro, N.J. 07746 or for Mastercard, Visa, and C.O.D. deliveries call **(201)431-3472**. Please add \$3.00 for postage and handling. New Jersey residents add

6% sales tax.

Atari is a registered trademark of Atari.



# BREAKUP

by Loren Wright and Phil Daley

---

## **BREAKUP**

requires:

VIC-20

Easily modifiable for other  
PETS

---

---

**A simple animation demonstration of PEEKing and  
POKEing screen memory.**

---

**G**et out your paddles or joystick and get ready to hit the ball with your bumper. By knocking down a wall of bricks, you can now show all your friends how dexterous you are.

Breakup is a simple animation display game that presents the principles of PEEKing and POKEing the screen memory to plot and erase characters on the screen, and to test for collisions. It includes a "ball" that moves around the screen, rebounds from struck objects, and knocks out blocks in the wall of bricks. It also includes a player-controlled "bumper" to keep the ball from going out-of-bounds and being lost, a defined playing field with three walls from which to bounce the ball, and two rows of blocks to be knocked off by your bouncing ball.

The game keeps score; 5 for each block and 1 for each bounce off the bumper. The previous highest score during each session is kept and displayed at the end of the game. More than 170 points qualifies you for a bonus of 50 points, new blocks, and an extra ball. You can choose to play with a joystick, paddles, or keyboard. If you choose the keyboard, the Function keys F1 and F7

move the bumper up and down. If you hold down the shift key at the same time, it increases the bumper movement speed.

## **Operating Instructions**

1. Type in the BREAKUP program and type 'RUN'.
2. You are first asked whether you have a joystick, paddles, or will play from the keyboard. Choose the correct response — J, P, or K.
3. If you specify hardware that you don't have, you will have to press the RUN/STOP key to recover.
4. The program will display the playing field, the brick wall, and your bumper. When you are ready to start play, press the button on the joystick or paddle X, or the space bar if you are using the keyboard.

## **The Program**

The ball starts from a random position on the left side of the screen and travels to the right, hitting a block. This causes the block to disappear, adds five to your score, and the ball rebounds toward the left. Here is the challenge: You must position the bumper to keep the ball from travelling out-of-bounds and off the screen, thereby losing the ball. If you are successful, the ball will rebound back toward the blocks. If you miss the ball, the game freezes so that you can see how close (or how far) you were from the ball when you missed it. You are allowed three balls (four if you get the bonus), so try not to miss. You will notice that the angle and speed of the ball increase the closer you hit the ball to the ends of the bumper. Hitting the ball near the center of the



bumper helps to restore the ball to the original direction.

The program stores the high score from game to game until the computer is turned off.

Challenge your friends to a match and see who can get the highest score.

To create animation on a computer screen, we need to know how the computer displays information on the screen and how we can change that information. The television is constantly updating the information being displayed, about 30 times per second. A computer that uses memory-mapped video stores the screen information in RAM (Random Access Memory) so that the video display routine can have this information available at all times. The location in memory where this information is stored on the VIC depends on the amount of memory available on your particular VIC. The formula for determining this location is:

$$1. S = 4 * (\text{PEEK}(36866) \text{AND } 128) + 64 * (\text{PEEK}(36869) \text{AND } 112)$$

S returns with the start of video display memory location.

To plot a character in a given location on the screen, we must use the following equation:

$$2. A = S + X + 22 * Y$$

where A is the location in memory to either PEEK or POKE the character, depending upon the program usage. X and Y are the Cartesian coordinates of the location, starting at 0,0 in the upper left corner of the screen.

Appendix D of the *VIC Programmer's Reference Guide* contains a table of the codes to be POKEd in screen memory and the resulting characters. As an example, type equation 1 above into your VIC to assign the proper value to S, and then type 'POKE 36879,8 : POKE S, 81'. A small white ball should appear on your screen in the upper left corner. We used equation 2 above with X = 0 and Y = 0. By changing the X and Y values in that equation and POKing the resulting locations with 81, you can print little white balls anywhere on the screen. X values can range from 0 to 22 and Y values from 0 to 20.

How do you erase them? Look up 'space' (which is 32 in the screen code chart and POKE that number into the same location as you originally plotted the ball. This effectively erases whatever is on the screen position. Location 36879 is the memory position for the background and border colors on the screen. Appendix B of the *VIC Programmer's Reference Guide* lists all the possible backgrounds and borders and the correct number to be POKEd into this location. The

reason for turning the background black and plotting the ball white is that white is the default color when POKing the screen memory locations.

POKING an 81 to the S location with the screen set to white results in an invisible ball being plotted. To see the ball on a white screen we have to change the color of the ball. Each screen memory location also has associated with it a screen color memory location. For example, if you POKE 38520,2, this will change the white ball to red. Since two locations must be POKed for any color other than white, we use white as the ball color to improve the speed of the program and lessen the complexity of the plotting routines.

## Paddles and Joysticks

Using paddles or a joystick helps to make the game more interesting and easier to play, but programming them is a little obscure, especially for the novice BASIC programmer. If you don't understand the following information on first reading, look at the BREAKUP program and see how it is done, then reread this section.

There are five switches on a joystick. Four of them are controlled by the joystick and one is for the fire button. You must PEEK the locations of the VIA to determine which joystick switches are closed. The values are normally 0 and change to 1 (or -1) when closed. We also have to POKE the Data Direction Register to input mode. For VIA #1 this is accomplished easily by a POKE 37139,0. Changing VIA #2 to input disables keyboard input, so we change only the DDR when we are polling the joystick and return it to normal during the rest of the program. Therefore, we POKE 37154,127, read the joystick, and POKE 37154,255 immediately afterward.

Reading switches 0, 1, 2, and 4 are done as follows:

```
POKE 37139,0
S0 = ( (PEEK(37137)AND4) = 0)
S1 = - ( (PEEK(37137)AND8) = 0)
S2 = ( (PEEK(37137)AND16) = 0)
S4 = - ( (PEEK(37137)AND32) = 0)
```

Reading switch 3 is a bit trickier:

```
POKE 37154,127
S3 = - ( (PEEK(37152)AND128) = 0)
POKE 37154,255
```

Because BREAKUP uses only up and down readings of the joystick, the switch 3 program lines are not needed. Switch 0 is North, switch 1 is South, switch 2 is West, switch 3 is East, and switch 4 is the fire button.



The VIC paddles are read in the same manner except that an actual value may be PEEKed for the paddle settings. The switches are the same. Here are the lines necessary to implement paddle readings:

```
POKE 37139,0          Set DDR to Input
PX = PEEK(36872)      Paddle X value
SX = -(PEEK(37137)
AND16 = 0)           Paddle X switch
PY = PEEK(36873)      Paddle Y value

POKE 37154,127
SY = -(PEEK(37152)
AND128) = 0)         Paddle Y switch
POKE 37154,255
```

### Program Description

Lines 1000-1020 (the subroutine to plot the bumper) calculate the screen position of the bumper and then POKE the locations either with a bar (B = 245) or a space (B = 32), depending on whether the subroutine is called to plot or erase the bumper. Lines 3070 and 3090 erase and draw the ball, respectively. Line 3080 looks at the screen location to see if a block has been hit. If so, the subroutine at line 5000 is called to update the score and put "english" on the ball if it was called because of bumper contact.

Lines 4050-4060 plot the block walls. If you remove lines 4050 and 4060, the game turns into "PONG" with the player scoring one point for each rebound from the bumper. Line 4140 picks a random spot along the left-hand side of the screen for the new ball to appear.

Line 3050 tests for out-of-bounds in the Y range and line 3100 tests for out-of-bounds in the X range. If the ball is out-of-bounds it reverses the ball direction. Line 3120 tests for hitting the bumper. If it has hit the bumper then the 5000 subroutine is called to update the score and put english on the ball, as previously mentioned.

As a whole, the routine moves rather slowly due to the limitations of BASIC language. We employed several techniques to keep the program moving as fast as possible. Variables used most often (those concerning the ball and bumper) were initialized at the beginning of the program so that they would be placed in the beginning of the variable storage area. The screen update subroutines were placed near the beginning of the program so that the interpreter would spend less time looking for the line numbers of the subroutines. In line 2010 (the bumper moving routine) a return is placed in the first line so that when the bumper is not to be moved, the program doesn't spend time replotting an unmoved bumper. That is why the ball moves much faster

when you are not changing the bumper location on the screen.

The screen POKEs can be any character (see the screen code chart in the programming manual). Breakup uses 32 (the space) to erase the screen. The ball is 81, the blocks are 102, the bumper is 245. These could be changed easily to different shapes. The scoring subroutine at line 5000 can be changed to make the score advance either faster or slower. Also, the scoring could be changed to increase the bonuses or provide snappy comments at the conclusion of the game. The block-plotting routine at line 4050 could be modified to increase or decrease the number of columns of blocks. If you plot them nearer to the bumper, then the 15 in line 3080 will need to be decreased commensurately.

### Changes for Other PETs

The POKEs in 3050, 3080, 3110, 3130, 3150, 4020, 4170, 4250, 6000, and 6090 may be removed. They control screen color and bounce sounds.

```
4000 COL = 40
4010 S0 = 32768
```

After typing the program as is, other PET owners should make these changes:

```
2090 S = 0:IF A$ = " " THEN S = 1
2100 IF A$ = CHR$(20) THEN S = -1
2110 IF A$ = " ^ " THEN S = 3
2120 IF A$ = CHR$(148) THEN S = -3
```

Line 4010 is also different for the C-64:

```
4010 S0 = 1024
```

You may contact the authors at MICRO Magazine, Box 6502, Amherst, New Hampshire 03031.

#### Breakup Listing

```
10 X=0:Y=0:X1=X:Y1=Y:S0=X:COL=X:S1=X:S2=S:S3=X:DV=X:DX=X:GOTO4000
1000 S1=S0+COL:AA=S2+S0+COL*(A+1):S3=S0+COL*(A+2)
1010 POKES1,B:POKES2,B:POKES3,B
1020 RETURN
2000 TS=INT((PEEK(36872)/17)+2
2010 IF TS<A+2AND TS>A-2 THEN RETURN
2020 B=SP:GOSUB1000
2030 A=TS:GOTO2150
2040 O0=-(PEEK(PA)AND4)=0:O1=-(PEEK(PA)AND8)=0
2050 IF O0<>O1 THEN S=-3:GOTO2130
2060 IF O1<>O1 THEN S=3:GOTO2130
2070 RETURN
2080 GETA$:IF A$="" THEN RETURN
2090 S=0:IF A$=" " THEN S=1
2100 IF A$="■" THEN S=-1
2110 IF A$="■" THEN S=3
2120 IF A$="■" THEN S=-3
2130 B=SP:GOSUB1000
2140 A=R+S
2150 IF A<2 THEN A=2
2160 IF A>17 THEN A=17
2170 B=D:GOSUB1000
2180 RETURN
3000 OK=1
3010 ON PDL GOSUB 2000,2040,2080
3020 X1=X:Y1=Y
3030 V=Y+DV:IF V>19 THEN V=19
3040 IF V<2 THEN V=2
3050 IF V=20 THEN V=19:THENDV=DV:POKEV3,230
3060 X=X+DX:IF X>19 THEN X=19
```

(Continued on page 78)



# Addressfile

by Brian Zupke

The program Addressfile stores names, addresses, phone numbers, and memos in cassette files. Entries can be entered, deleted, or changed, and files can be updated at any time. By using the search routine, you can locate any entry having a particular name, address, phone number, or memo.

The program was written on a 13K VIC-20.

However, if the REM statements are deleted, it will run with 8K. Since the program is somewhat large, I am offering to make a copy of it for anyone who sends me either a blank tape and a self-addressed, stamped envelope, or \$3.00.

To allow for fast and easy data entry and editing, INPUT statements were used. This means that no colons or commas are allowed. The program has eight major functions: ADD ENTRIES, CHANGE ENTRIES, VIEW ENTRIES, DELETE ENTRY, SEARCH FILE, SAVE FILE, LOAD FILE, and END PROGRAM. Below are detailed descriptions of each function.

**ADD ENTRIES** — Add new entries to the file.

Added entries are put at the end of the current file, or the file presently in memory. After typing an entry, the computer asks if you want to make any changes. The default is 'N'. If you type 'Y', then the cursor moves to the top of the entry and it is re-entered. If you don't want to change a certain line in the entry, just hit RETURN; otherwise make the change and then hit RETURN. Be sure to hit RETURN on each line of the entry since the computer is INPUTting all of them again. If you do not want to make any changes then the computer will ask if you are finished adding entries to the file. The default is 'N'. You must type a 'Y' to return to the menu.

**CHANGE ENTRY** — Change any part or all of an entry.

The computer first asks for the number of the entry to be changed. If you don't want to change an entry respond with a number less than one, which returns control to the menu. When a valid entry number is typed in, that entry is listed. Question marks are printed out before each line so that the entry can be re-entered. Change the entry as you would when adding entries. After the changes are made, the computer asks if you want to change another entry. The default is 'Y'. Control is returned to the menu if you type 'N'.

**VIEW ENTRIES** — View any or all entries in the file.

The computer first asks for a starting entry to be viewed. When a number is typed in, the corresponding entry is displayed. The computer will then ask if you want to see another entry. The default is 'Y'. If the response is 'N', then control is returned to the menu; otherwise, the entry immediately following the one on the screen is displayed. For example, if the sixth entry is on the screen, the seventh entry will be displayed next. After the last entry is displayed and you request to see another entry, the computer will display an end-of-file message briefly and control is returned to the menu.

**DELETE ENTRY** — Delete an entry in the file.

The computer asks for the number of the entry to be deleted. Once a number is typed in, the corresponding entry is displayed. The computer



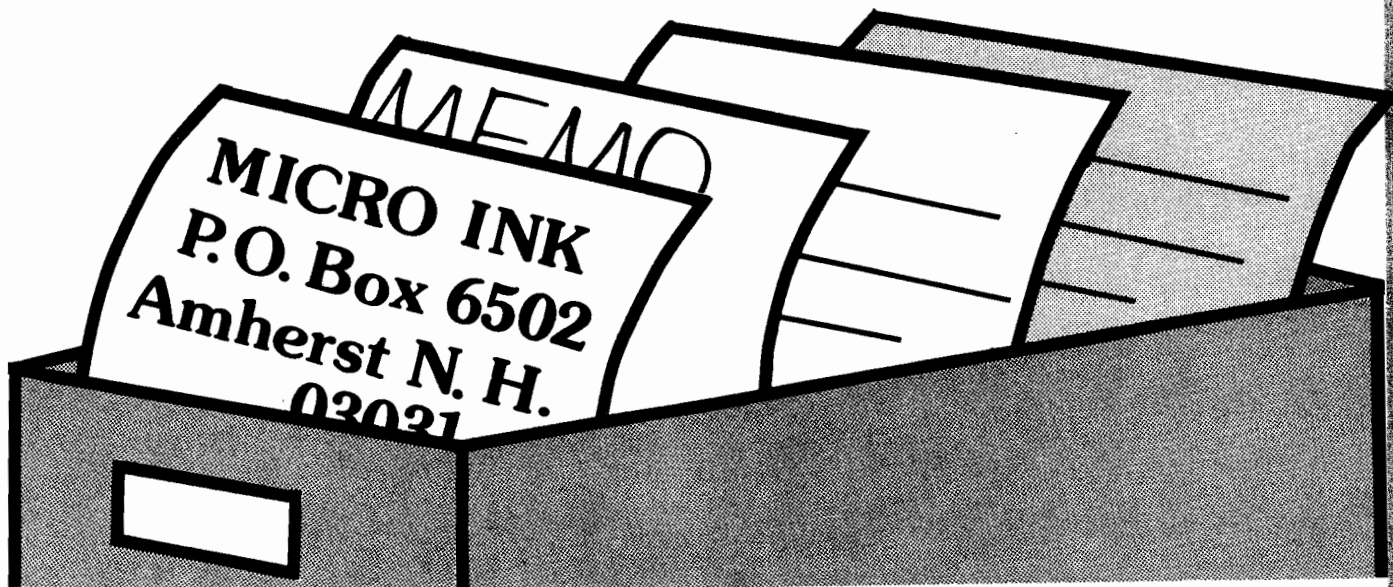

asks if you want to delete the entry displayed. If you type 'Y', then the entry is deleted and all the entries above that one are moved down one. For example, if entry six is deleted, then entry seven becomes entry six, eight becomes seven, etc. If you type 'N' the entry is not deleted. In either case, the computer will ask for another entry number. If you type a number less than one, control is returned to the menu.

**SEARCH FILE** — Search the current file for a specific name, address, etc.

There are four things you can search for in the file: the name, address, phone number, or memo. After choosing one, the computer will ask if you want a full printout of each entry in the file that matches. The default is 'Y'. If you type 'N' then only the entry number is printed. Then the computer will ask if you want a pause after each match is printed. Again the default is 'Y'. With the pause, a key will have to be pressed after each match is listed. Then the computer will ask for the specific item for which to search. If you are searching for a name and two names are typed in (first and last), the computer will check both names individually. This is true for names in an entry. If either name typed in matches either name in an entry, then a match is found. When searching for an address, a match is found if the street is the same, the city is the same, or if the state and zip code are the same as the entry's. With the phone number and memo, a match is found when they are the same as the entry's. When all entries have been checked an end of search message is displayed. A key has to be pressed to return to the search menu. If you are through searching, press '5' to return to the menu.

**SAVE FILE** — Save current file on cassette tape.

The computer asks for a name under which to save the file. After you type in the name, the computer will display the press play and record message. Once you start the tape, the computer will open and save the file, and once the file is saved, it is CLOSED and control is returned to the menu. When you save a file you must be sure of two things: don't overwrite another file, and make sure that each line in every entry has at least one character or number in it. If you fail to do this the entries will contain the wrong information when the file is loaded back in. This happens because the computer will pass over a blank line and INPUT# the first non-blank line in the same variable, which causes the entries to 'bunch up.'

**LOAD FILE** — Load a file from tape into the computer.

The computer asks for the name of the file you wish to load. When a name is typed in, the corresponding file is loaded into the computer. Control is returned to the menu after the file is loaded.

**END PROGRAM** — Terminates program.

Caution should be taken with this function. Be sure that you save any wanted files on tape before quitting.

*(Addressfile Listing on next page)*



### Addressfile Listing

```

10 REM *****
11 REM * * * * *
12 REM * ADDRESSFILE *
13 REM * * * * *
14 REM * BY *
15 REM * * * * *
16 REM * BRIAN ZUPKE *
17 REM * * * * *
18 REM * * * * *
19 REM * * * * *
20 REM *****
99 REM
100 DIMS(100),SA(100),CS(100),TS(100),ZS(100),MS(100),FS(100),E(100)
130 REM * PRINT MAIN MENU *
150 PRINT "ADDRESSFILE"
160 PRINT "MENU"
170 PRINT "3) VIEW ENTRIES"
175 PRINT "4) DELETE ENTRY"
180 PRINT "5) SAVE FILE"
185 PRINT "6) LOAD FILE"
190 PRINT "7) END PROGRAM"
195 REM * INPUT USERS CHOICE *
200 PRINT "CHOICE"
210 PRINT "1) ADD ENTRIES"
220 PRINT "2) CHANGE ENTRIES"
230 PRINT "3) VIEW ENTRIES"
240 PRINT "4) DELETE ENTRY"
250 PRINT "5) SAVE FILE"
260 PRINT "6) LOAD FILE"
270 PRINT "7) END PROGRAM"
280 INPUT "CHOICE"
290 IF CHOICE=1 THEN GOTO 300
300 REM * ADD ENTRY *
310 PRINT "NAME"
320 PRINT "STREET"
330 PRINT "CITY"
340 PRINT "STATE"
350 PRINT "ZIP CODE"
360 PRINT "PHONE"
370 INPUT "NAME"
380 INPUT "STREET"
390 INPUT "CITY"
400 INPUT "STATE"
410 INPUT "ZIP CODE"
420 INPUT "PHONE"
430 REM * CHECK IF NEW ENTRY NEEDS TO BE CHANGED *
440 INPUT "CHANGE"
450 IF CHANGE THEN GOTO 300
460 REM * CHANGE ENTRY *
470 PRINT "NAME"
480 PRINT "STREET"
490 PRINT "CITY"
500 PRINT "STATE"
510 PRINT "ZIP CODE"
520 PRINT "PHONE"
530 INPUT "NAME"
540 INPUT "STREET"
550 INPUT "CITY"
560 INPUT "STATE"
570 INPUT "ZIP CODE"
580 INPUT "PHONE"
590 REM * VIEW ENTRIES *
600 PRINT "STARTING ENTRY"
610 FOR X=1 TO 100
620 PRINT X
630 PRINT "NAME"
640 PRINT "STREET"
650 PRINT "CITY"
660 PRINT "STATE"
670 PRINT "ZIP CODE"
680 PRINT "PHONE"
690 NEXT X
700 REM * DELETE ENTRY *
710 PRINT "ENTRY"
720 INPUT "ENTRY"
730 REM * SEARCH ENTRIES *
740 PRINT "SEARCH"
750 PRINT "NAME"
760 PRINT "STREET"
770 PRINT "CITY"
780 PRINT "STATE"
790 PRINT "ZIP CODE"
800 PRINT "PHONE"
810 INPUT "SEARCH"
820 IF SEARCH THEN GOTO 830
830 REM * SEARCH FOR NAME *
840 PRINT "SEARCH FOR NAME"
850 PRINT "SEARCH FOR ADDRESS"
860 PRINT "SEARCH FOR PHONE"
870 PRINT "SEARCH FOR MEMO"
880 PRINT "RETURN TO MENU"
890 INPUT "SEARCH"
900 IF SEARCH THEN GOTO 910
910 REM * SEARCH FOR NAME *
920 PRINT "SEARCH FOR NAME"
930 PRINT "SEARCH FOR ADDRESS"
940 PRINT "SEARCH FOR PHONE"
950 PRINT "SEARCH FOR MEMO"
960 PRINT "RETURN TO MENU"
970 INPUT "SEARCH"
980 IF SEARCH THEN GOTO 990
990 REM * SEARCH FOR ADDRESS *
1000 PRINT "SEARCH FOR ADDRESS"
1010 PRINT "SEARCH FOR PHONE"
1020 PRINT "SEARCH FOR MEMO"
1030 PRINT "RETURN TO MENU"
1040 INPUT "SEARCH"
1050 IF SEARCH THEN GOTO 1060
1060 REM * SEARCH FOR PHONE *
1070 PRINT "SEARCH FOR PHONE"
1080 PRINT "SEARCH FOR MEMO"
1090 PRINT "RETURN TO MENU"
1100 INPUT "SEARCH"
1110 IF SEARCH THEN GOTO 1120
1120 REM * SEARCH FOR MEMO *
1130 PRINT "SEARCH FOR MEMO"
1140 PRINT "RETURN TO MENU"
1150 INPUT "SEARCH"
1160 IF SEARCH THEN GOTO 1170
1170 REM * RETURN TO MENU *
1180 PRINT "RETURN TO MENU"
1190 INPUT "SEARCH"
1200 IF SEARCH THEN GOTO 1210
1210 REM * END PROGRAM *
1220 PRINT "END PROGRAM"
1230 INPUT "SEARCH"
1240 IF SEARCH THEN GOTO 1250
1250 REM * END PROGRAM *
1260 PRINT "END PROGRAM"
1270 INPUT "SEARCH"
1280 IF SEARCH THEN GOTO 1290
1290 REM * END PROGRAM *
1300 PRINT "END PROGRAM"
1310 INPUT "SEARCH"
1320 IF SEARCH THEN GOTO 1330
1330 REM * END PROGRAM *
1340 PRINT "END PROGRAM"
1350 INPUT "SEARCH"
1360 IF SEARCH THEN GOTO 1370
1370 REM * END PROGRAM *
1380 PRINT "END PROGRAM"
1390 INPUT "SEARCH"
1399 REM *****

```

```

1006 REM JUMP TO CORRECT MATCH CHECK
1010 FOR X=1 TO E-1:GOTO1100,1150,1210,1190
1015 REM CONTINUE SEARCH
1020 NEXT X:PRINT "END OF SEARCH"
1030 GETA:IF A#"" THEN GOTO1030
1035 GOTO1060
1037 REM MATCH FOUND-PRINT ENTRY *
1040 PRINT "ENTRY"
1046 REM PRINT NAME, ADDRESS & MEMO OF MATCH
1050 PRINT "NAME"
1055 PRINT "ADDRESS"
1060 PRINT "MEMO"
1065 PRINT "PHONE"
1070 PRINT "MEMO"
1076 REM PAUSE BEFORE CONTINUING SEARCH
1080 GETA:IF A#"" THEN GOTO1080
1085 GOTO1030
1094 REM * CHECK NAME OF ENTRY FOR MATCH *
1096 REM FIND FIRST & LAST NAME
1100 FOR Y=1 TO LEN(N):IF MID(N,Y,1)="" THEN GOTO1100
1110 NEXT Y:IF N#"" THEN GOTO1105
1120 FOR X=1 TO N:IF MID(N,X,1)="" THEN GOTO1105
1130 REM MATCH IF SAME FIRST OR LAST NAME
1135 IF L#F OR R#S OR L#S OR R#F THEN GOTO1140
1137 REM NO MATCH FOUND, CONTINUE SEARCH
1140 GOTO1030
1142 REM * CHECK ADDRESS OF ENTRY FOR MATCH *
1144 REM MATCH IF SAME STREET
1150 IF S#S THEN GOTO1144
1155 REM MATCH IF SAME CITY
1160 IF C#C THEN GOTO1144
1165 REM MATCH IF SAME STATE & ZIP CODE
1170 IF T#T AND Z#Z THEN GOTO1144
1175 REM NO MATCH FOUND, CONTINUE SEARCH
1180 GOTO1030
1182 REM * CHECK MEMO OF ENTRY FOR MATCH *
1184 REM MATCH IF SAME MEMO
1190 IF M#M THEN GOTO1144
1195 REM NO MATCH FOUND, CONTINUE SEARCH
1200 GOTO1030
1207 REM * CHECK PHONE # OF ENTRY FOR MATCH *
1209 REM MATCH IF SAME PHONE #
1210 IF P#P THEN GOTO1144
1215 REM NO MATCH FOUND, CONTINUE SEARCH
1220 GOTO1030
READY.

```



### Breakup Listing (continued)

```

3070 POKES0+X1+COL*Y1,SP
3080 IF X=5 AND PEEK(50+X+COL*Y)=102 THEN POKEV1,255:0=5:GOSUB5000
3090 POKES0+X+COL*Y,SP
3100 IF X=1 AND X=19 THEN GOTO3150
3110 IF X=15 THEN GOTO3150
3120 IF X=1 AND Y=ADRV#A-1 AND DY=0 AND YC=A-2 OR Y=A+2 AND DY=0 THEN FLAG=1
3130 IF FLAG=1 THEN FLAG=0:DX=0X:POKEV3,220:GOSUB5000:GOTO3150
3140 BALL=BALL-1:0K=0:POKES0+X1+COL*Y1,SP:RETURN
3150 POKEV1,0:POKEV3,0:RETURN
4000 V1=36874:V3=36876:CS=36879:PA=37137:POKEV1,0:COL=22
4010 S0=44:PEEK(36866) AND 128:V2=44:PEEK(36869) AND 112
4020 POKES0,30:GOSUB6000:POKES0,128
4030 A=2:0=0:GOSUB1000
4040 BALL=3:0=0
4050 FOR I=1 TO 18 STEP 2:FOR Y=2 TO 19
4060 POKES0+X+COL*Y,102:NEXT Y
4070 IF BUSTHEN A=0
4080 SCORE=-1:GOSUB5000
4090 ON PDL GOTO 4100,4100,4130
4100 BUT=-1:(PEEK(PA) AND (PDL*16))=0
4110 IF BUT<1 THEN A=100
4120 GOTO 4140
4130 GETA:IF A#"" THEN GOTO4130
4140 X=2:Y=INT(RND(1)*14)+2:0X=1:0V=1
4150 GOSUB5000
4160 IF OK THEN A=150
4170 POKEV3,0
4180 ON PDL GOTO 4190,4190,4220
4190 BUT=-1:(PEEK(PA) AND (PDL*16))=0
4200 IF BUT<1 THEN A=190
4210 GOTO 4230
4220 GETA:IF A#"" THEN GOTO4220
4230 POKES0+X+COL*Y,SP
4240 IF BALL THEN SCORE=SCORE+1:GOSUB5000:GOTO 4140
4250 POKES0,27:PRINT "SCORE OVER"
4260 PRINT "NEW SCORE"
4270 PRINT "POINTS"
4280 PRINT "PREVIOUS HIGH WAS"
4290 PRINT "PRESS SPACE TO CONT."
4300 GETA:IF A#"" THEN GOTO4300
4310 GOSUB6000
4320 GOTO 4030
5000 SCORE=0:PRINT "BALL"
5010 IF NOT (BUSTHEN SCORE=170 THEN SCORE=SCORE+50:BALL=BALL+1:ENUS=-1:POKEV1,0
:GOTO 4030
5020 IF 0=5 THEN DX=0X:GOTO 5030
5030 IF Y<RANDV<0 THEN DY=-2*DY:GOTO 5030
5040 IF Y>A+1 AND DY<0 THEN DY=-2*DY:GOTO 5030
5050 DY=DY/2
5060 IF DY<0 AND DY<1 THEN DY=1
5070 IF DY<0 AND DY<-1 THEN DY=-1
5080 0=1:RETURN
6000 POKES36879,15:PRINT "
6010 PRINT "MICRO BREAKUP"
6020 PRINT "KEYBOARD, STICK, JOYSTICK OR JOYSTICK"
6030 GETA:IF A#"" THEN GOTO6030
6040 IF A#"" THEN PDL=1:GOTO6030
6050 IF A#"" THEN PDL=2:GOTO6030
6060 IF A#"" THEN PDL=3:GOTO6030
6070 IF A#"" THEN PRINT "END
6080 GOTO 6030
6090 POKES0,8
6100 V#=""
6110 D=245:SP=32:BL=81
6120 PRINT "
6130 PRINT "
6140 FOR I=1 TO 18:PRINT TAB(20);I;"NEXT
6150 PRINT "
6160 RETURN
READY.

```



# FOR COMPLETE GRAPHICS: VersaWriter

EDUCATION

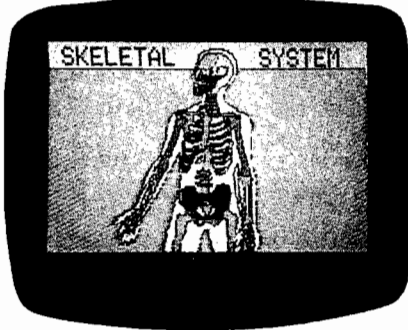

ARTIST



GAME PROGRAMMER

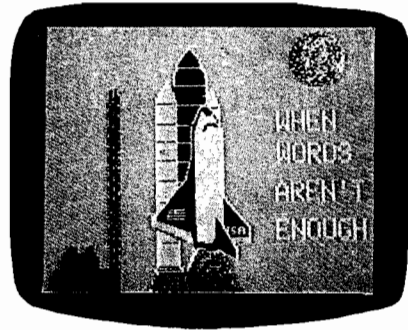

HOBBIST

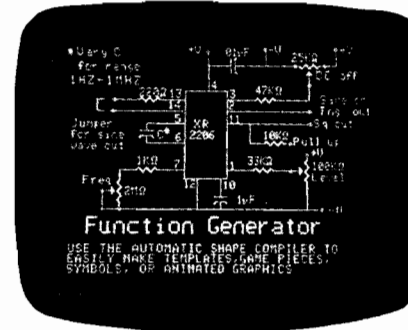

ENGINEERING



CHILDREN

Teachers, artists, engineers, programmers & hobbyists find VersaWriter an easy to use tool for creating micro computer graphics. No programming experience is required. Pictures can be made by simply tracing. Even children can explore the exciting world of computer graphics. The VersaWriter is as limitless as your imagination.

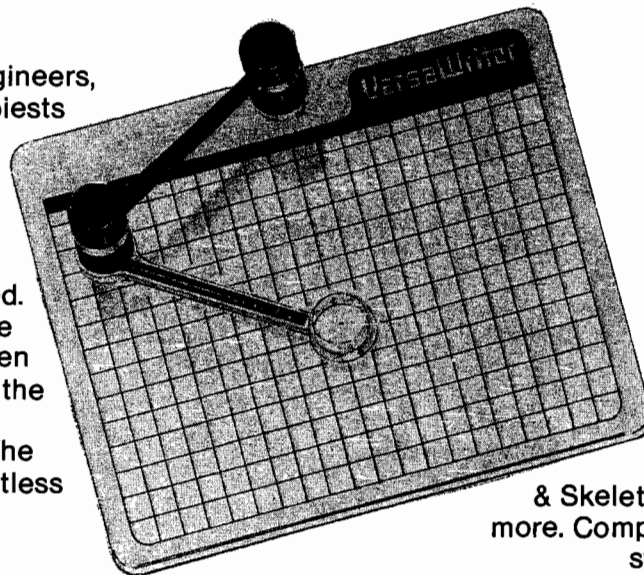

VersaWriter contains complete software for drawing with color, brushes & dots. Add text or fill in over 100 colors. Create your own shapes and place anywhere on the screen. Use Area/Distance, Move Picture, Electronic Drawing & Skeleton programs plus much more. Complete hardware/software system for Apple II/II+/Ile - \$299.00



Versa Computing Products are available at your local computer products store.

Distributed by:

Computerland Corp.  
Hayward, Calif.  
Softsel Computer Products  
Inglewood, Calif.  
Pete & Pam Computers  
Lancashire, England

Micron Distributing  
Toronto, Canada  
Program Spektrum  
Bromma, Sweden  
Micro Products Sales Group  
Lynn, Mass.

VersaWriter is also available with software designed for Atari & IBM PC.

Educational Media  
Washington, Penn.  
ESD Laboratories  
Tokyo, Japan  
Blue Ridge Computers  
Capetown, South Africa

3541 Old Conejo Road, Suite 104 • Newbury Park, CA 91320 • (805) 498-1956

# Apple Graphics for Okidata Microline 80: Revisited

by Gary Little

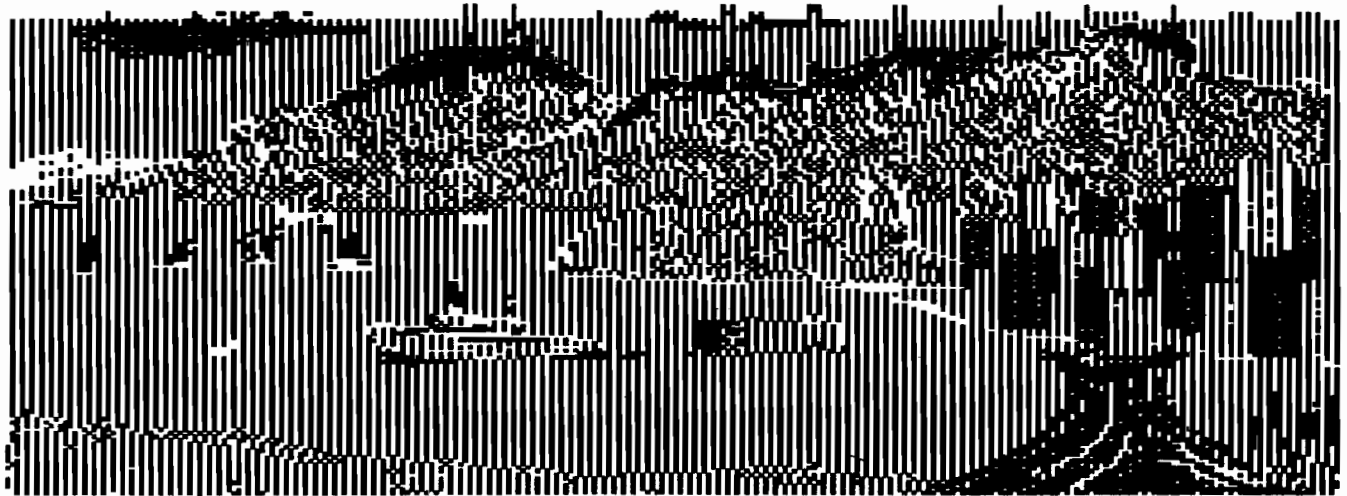

---

**This article describes how to print the Apple II's high-resolution graphics screens on an Okidata Microline 80 printer.**

---

---

## Graphics Dump requires:

Apple II and  
Microline 80 printer.

---

I've had my Okidata Microline 80 printer for almost two years. When I first bought it, I used it primarily to facilitate program development. Currently, I am using it also for writing letters, reports, and magazine articles such as this one.

Until recently I had never used the printer for generating a hard-copy version of the display on either of the Apple's high-resolution screens. I didn't have a need to do this because I rarely write graphics software. Even so, I recognized that it would be a challenge to convert the pixels on an Apple graphics screen into a stream of bytes that would tell the Okidata to print one of its TRS-80-style 2x3 block-graphics characters, and still have the resultant output resemble the original picture!

The problem became more difficult when I discovered that to print a block-

graphics character, the high-order bit of each byte sent to the printer has to be set to 1. The firmware on my Centronics-style parallel interface card sets this bit to 0. Then I read "Apple Graphics for Okidata Microline 80" by Charles F. Taylor (MICRO 48:48). That article described a Pascal program to solve the very problem I was attempting to solve. It also included a 6502 assembly-language program that could be used in a DOS environment. In addition, Charles described a simple method to circumvent the high-bit hardware problem.

A quick review of the article convinced me that there was still some programming to be done. I wanted to be able to print the *full* graphics screen sideways on the paper. This would give the largest size possible and would fit nicely on legal-size 8½" x 14" paper. The Pascal program listed in Charles's article does this, but not the assembly-language program. Since I don't use Pascal, I had to solve the 'full screen' problem using 6502 assembly language.

## Solving the Hardware Problem

To solve the hardware problem

previously mentioned, all you have to do is locate the wire used to transmit the high-order data bit between the printer interface card and the printer connector, sever it, and then extend the wire from the printer side to pin 15 of the game I/O connector. This pin corresponds to what is called annunciator 0 and can be set to a high or low voltage by reading locations \$C059 or \$C058, respectively. This, in turn, will either set or clear the high-order bit of the character being sent to the printer (at least in the printer's eyes).

From 6502 assembly language, enter the command

```
LDA $C059
```

to set the high bit before sending graphics characters, or enter the command

```
LDA $C058
```

to clear the high bit before sending ordinary text.

That's it for the hardware problem. If this modification is made there is no need to change the hardware switch described in Charles's article since everything is handled under software control. And since annunciator 0 is off when the Apple is first turned on, or after a RESET, there is little danger that you will send graphics when you intend

# Apple Graphics Microline 80: R

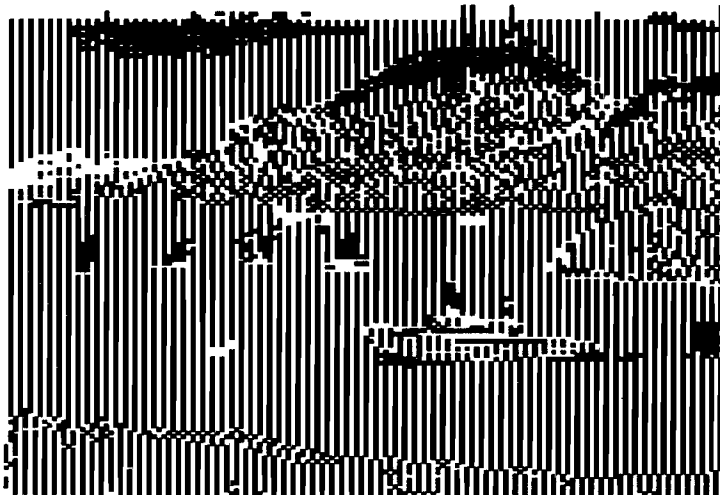

---

This article describes how to print the Apple II's high-resolution graphics screens on an Okidata Microline 80 printer.

---

## Graphics Dump requires:

Apple II and  
Microline 80 printer.

I've had my Okidata Microline 80 printer for almost two years. When I first bought it, I used it primarily to facilitate program development. Currently, I am using it also for writing letters, reports, and magazine articles such as this one.

Until recently I had never used the printer for generating a hard-copy version of the display on either of the Apple's high-resolution screens. I didn't have a need to do this because I rarely write graphics software. Even so, I recognized that it would be a challenge to convert the pixels on an Apple graphics screen into a stream of bytes that would tell the Okidata to print one of its TRS-80-style 2x3 block-graphics characters, and still have the resultant output resemble the original picture!

The problem became more difficult when I discovered that to print a block-

graphics character, the bit set to 1. The firmware trons-style parallel into this bit to 0. Then Graphics for Okidata Micro Charles F. Taylor (MICRO article described a Pascal solve the very problem ting to solve. It also in assembly-language prog be used in a DOS enviro tion, Charles descri method to circumvent hardware problem.

A quick review of t vinced me that there programming to be done able to print the *full g* sideways on the paper. T the largest size possible nicely on legal-size 8½' The Pascal program list article does this, but not language program. Sinc Pascal, I had to solve th problem using 6502 asse

## Solving the Hardware

To solve the hard

Subscribe to  
**MICRO**

Subscribe to  
**MICRO**

Subscribe to  
**MICRO**

Subscribe to  
**MICRO**

Subscribe to  
**MICRO**

to send text to the printer. (If this happens, press RESET to re-enable 'text' mode.)

### Solving the Software Problem

The MICRO article was most useful to me for its description of how to convert six pixels on the Apple screen into an equivalent TRS-80 2x3 block-graphic character. All I needed to write was a high-resolution SCRIN subroutine to tell me whether a particular pixel was on or off. This subroutine begins at line 127 of the source listing shown below. It is a general-purpose subroutine and could be used in other applications, if required. Upon return from the subroutine, the carry flag will be set if the pixel corresponding to row ROWNUM and column COLNUM is on, and will be clear if the pixel is off.

Since the picture is going to be printed sideways on the paper, the rows of each 2x3 block-graphic character will correspond to columns on the high-resolution screen and the columns to rows. For a given ROW and COLUMN base, the corresponding block-graphic character is assembled as indicated in figure 1.

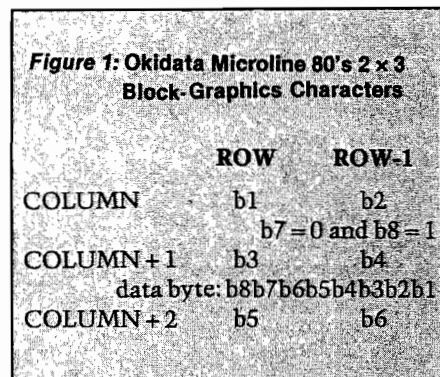

A sub-block is on if the corresponding pixel for (ROW,COLUMN) on the high-resolution screen is on, and is off if the pixel is off. The labels b1, b2, etc., refer to the bits in the block-graphic character byte.

The algorithm for printing the whole screen (page 2) is as follows:

1. ROW = 191 : COLUMN = 0
2. Assemble block graphic and print it
3. ROW = ROW - 2 : Repeat step 2 if ROW is not equal to \$FF
4. ROW = 191 : COLUMN = COLUMN + 3 : Repeat step 2 if COLUMN = 279

Page 1 of graphics can be dumped using the same routine by changing the variable PAGE from \$40 to \$20.

### How to Use the Program

The program resides in memory beginning at location \$6000, just above graphics page 2. (You will have to reassemble the source code if you wish to use the routine at a different location.) Use the BLOAD command to load it at this address from the diskette. Once your graphics image is in memory, enter the command CALL 24576 from BASIC to dump the image to the Microline 80. Note that the process can be aborted at any time by pressing ESC.

Although it takes several minutes for the full high-resolution screen to be printed, the results are worth it. Figure 1 shows an example of the result of a dump of graphics page 2.

### Conclusion

The assembly-language routine presented here can be used within larger assembly-language programs or can be CALLED from an Applesoft or Integer BASIC program. The hardcopy output will be centered perfectly if legal-size paper is used. I suspect that this program, together with those presented in Charles Taylor's article, will complete your Microline 80 graphics dump software library.

Mr. Little is a lawyer in Vancouver specializing in computer-related law. He owns an Apple II and is currently Vice President of Apple's British Columbia Computer Society. You may contact Mr. Little at #214-131 Water St., Vancouver, B.C., Canada V6B 4M3.

#### Listing 1: Graphics Dump

```

3 *****
4 * HIGH-RES SCREEN DUMP *
5 *   for the   *
6 * OKIDATA MICROLINE 80 *
7 *   *
8 * by Gary B. Little *
9 *   May 05/1982 *
10 *****
11 GBASL EPZ $26
12 GBASH EPZ GBASL+$1
13 ESCHR EQU $638
14 FLAGS EQU $6B8
15 PWDTH EQU $4B8
16 MODE EQU $5B8
17 KBD EQU $C000
18 STROBE EQU $C010
19 HIGHON EQU $C059 *Turns on Bit #7
20 HIGHOFF EQU $C058 *Turns off Bit #7
21 PRINTGR EQU $C102
22 ORG $6000
23 *****
24 * Initialize printer *
25 *****
6000 8D 58 C0 26 STA HIGHOFF *Turn off Graphics
6003 A2 C1 27 LDY #$C1
6005 A9 09 28 LDA #9
6007 9D B8 06 29 STA FLAGS,X
600A A9 FF 30 LDA #$FF
600C 9D B8 04 31 STA PWDTH,X
600F 9D 38 06 32 STA ESCHR,X
6012 A9 00 33 LDA #0
6014 9D B8 05 34 STA MODE,X
6017 20 49 61 35 JSR DISPLAY
601A 8D 36 HEX 8D
601B 1D 37 HEX 1D *16.5 Characters/inch
601C 1B 38 38 HEX 1B38 *8 Lines/inch
601E 1B 42 39 HEX 1B42 *105 Characters/line
6020 8D 00 40 HEX 8D00
6022 41 *****
6022 42 * Begin main routine *
6022 43 *****
6022 A9 00 44 LDA #0
6024 8D 42 61 45 STA COLNUM
6027 8D 43 61 46 STA COLNUM+1
602A AD 41 61 47 NXTLINE LDA PAGE
602D C9 40 48 CMP #$40
602F F0 04 49 BEQ PAGE2
6031 A9 9F 50 LDA #159
6033 D0 02 51 BNE SETPAGE
6035 A9 BF 52 PAGE2 LDA #191
6037 8D 44 61 53 SETPAGE STA ROWNUM
603A 8D 59 C0 54 STA HIGHON *Turn on Graphics
603D A0 02 55 NXTROW LDY #2
603F 20 D2 60 56 FORMGR JSR SCRINCHK
6042 6E 48 61 57 ROR GRAPHIC
6045 CE 44 61 58 DEC ROWNUM

```

(continued)

# App

can be used with  
programs or in  
assembly-language  
routines

tor and

Commands

- High resolution 320x200 pixel, 16 color graphics
- Sprite graphics for control of 32 sprites
- Three voice tone and music synthesizer
- Detailed manual with examples and BASIC-FORTH conversions
- Trace feature for Debugging

**\$99.95 — Disk Version**  
(Specify CBM 1540 or CBM 1541 Disk)

**\$99.95 — Cassette Version**  
(CBM & Commodore 64 are Trademarks of Commodore)

**PERFORMANCE MICRO PRODUCTS**  
770 Dedham Street  
Canton, MA 02021  
(617) 828-1209

Circle No. 43

## COMPU SENSE

### "CARD/?" (CARD/PRINT)

UNIVERSAL CENTRONICS  
PARALLEL PRINTER  
INTERFACE FOR THE VIC-20®

Now you can use your VIC-20® with an EPSON MX-80 printer, or an OKI-DATA printer, or a TANDY printer, or just about anybody's printer. And you don't have to give up the use of your user port (MODEM), or change to special printer commands, or load any special software driver programs to do it.

- Outputs standard ASCII codes to the printer.
- Plugs in the VIC-20® printer serial i/o port.
- Understands all standard VIC-20® print commands.
- No modification to your VIC-20®.
- No special programs required.
- Includes all necessary cables to hook up a standard printer using centronics parallel input.
- **MADE IN THE U.S.A.**

The "CARD/?" is a product of CARDCO, Inc.

**\$79.95**

TO ORDER:  
P. O. BOX 18765  
WICHITA, KS 67218  
(316) 263-1095



Personal checks accepted  
(Allow 3 weeks) or  
C.O.D. (Add \$2.00)  
Handling charges \$2.00  
VIC-20® is a registered trademark of Commodore

Circle No. 44

6048	20	D2	60	59	JSR	SCRNCHK	
604B	6E	48	61	60	ROR	GRAPHIC	
604E	EE	44	61	61	INC	ROWNUM	
6051	EE	42	61	62	INC	COLNUM	
6054	00	03		63	BNE	LOW	
6056	EE	43	61	64	INC	COLNUM+1	
6059	88			65	LOW	DEY	
605A	10	E3		66	BPL	FORMGR	
605C	38			67	SEC		
605D	6E	48	61	68	ROR	GRAPHIC	
6060	38			69	SEC		
6061	6E	48	61	70	ROR	GRAPHIC	
6064	AD	48	61	71	LDA	GRAPHIC	
6067	20	02	C1	72	JSR	PRINTGR	
606A	AD	00	C0	73	LDA	KBD	
606D	10	07		74	BPL	NGSTOP	
606F	2C	10	C0	75	BIT	STROBE	
6072	C9	9B		76	CMP	#9B	*ESC pressed?
6074	F0	43		77	BEQ	FINISH	
6076	38			78	SEC		
6077	AD	42	61	79	NOSTOP	LDA	COLNUM
607A	E9	03		80	SBC	#3	
607C	8D	42	61	81	STA	COLNUM	
607F	AD	43	61	82	LDA	COLNUM+1	
6082	E9	00		83	SBC	#0	
6084	8D	43	61	84	STA	COLNUM+1	
6087	CE	44	61	85	DEC	ROWNUM	
608A	CE	44	61	86	DEC	ROWNUM	
608D	AD	44	61	87	LDA	ROWNUM	
6090	C9	FF		88	CMP	#FF	
6092	D0	A9		89	BNE	NXTROW	
6094	8D	58	C0	90	STA	HIGHOFF	*Turn off Graphics
6097	A9	8D		91	LDA	#8D	
6099	20	02	C1	92	JSR	PRINTGR	
609C	18			93	CLC		
609D	AD	42	61	94	LDA	COLNUM	
60A0	69	03		95	ADC	#3	
60A2	8D	42	61	96	STA	COLNUM	
60A5	AD	43	61	97	LDA	COLNUM+1	
60A8	69	00		98	ADC	#0	
60AA	8D	43	61	99	STA	COLNUM+1	
60AD	F0	07		100	BEQ	ALLOK	
60AF	AD	42	61	101	LDA	COLNUM	
60B2	C9	17		102	CMP	#23	
60B4	F0	03		103	BEQ	FINISH	
60B6	4C	2A	60	104	ALLOK	JMP	NXTLINE
60B9				105	*****		
60B9				106	* Reset printer defaults *		
60B9				107	*****		
60B9	8D	58	C0	108	FINISH	STA	HIGHOFF *Turn off Graphics
60BC	20	49	61	109	JSR	DISPLAY	
60BF	8D			110	HEX	8D	
60C0	1E			111	HEX	1E	*10 Characters/inch
60C1	1B	36		112	HEX	1B36	*6 Lines/inch
60C3	1B	41		113	HEX	1B41	*80 Characters/line
60C5	8D	8D	8D	114	HEX	8D8D8D	
60C8	8D	8D	8D	115	HEX	8D8D8D	
60CB	8D	8D	8D	116	HEX	8D8D8D	
60CE	8D	8D	00	117	HEX	8D8D00	
60D1	60			118	RTS		
60D2				119	*****		
60D2				120	* This is a high-res SCR N *		
60D2				121	* function The result is *		
60D2				122	* returned in the carry *		
60D2				123	* flag If the carry is *		
60D2				124	* clear, then no color *		
60D2				125	* is present; if the *		
60D2				126	* carry is set, then *		
60D2				127	* color is present *		
60D2				128	*****		
60D2	98			129	SCRNCHK	TYA	
60D3	48			130	PHA		
60D4	A9	00		131			
					LDA	#0	
60D6	8D	45	61	132	STA	COLBYTE	
60D9	AD	42	61	133	LDA	COLNUM	
60DC	8D	47	61	134	STA	COLTEMP	
60DF	AD	43	61	135	LDA	COLNUM+1	
60E2	F0	0E		136	BEQ	NOT>255	
60E4	A9	24		137	LDA	#36	*If X-coord is >255
60E6	8D	45	61	138	STA	COLBYTE	* Add 36 to Byte#
60E9	18			139	CLC		* Add 4 to Low Byte
60EA	AD	47	61	140	LDA	COLTEMP	* of X-coord to
60ED	69	04		141	ADC	#4	* compensate
60EF	8D	47	61	142	STA	COLTEMP	
60F2	AD	47	61	143	NOT>255	LDA	COLTEMP
60F5	A2	00		144	LDX	#0	
60F7	38			145	DIVIDE7	SEC	*Calculate X/7
60F8	E9	07		146	SEC	#7	*(Byte position)

60FA 90 03	147	BCC OVER
60FC E8	148	INX
60FD B0 F8	149	BCS DIVIDE7
60FF 18	150	CLC
6100 69 07	151	ADC #7
6102 8D 46 61	152	STA COLBIT
6105 18	153	CLC
6106 8A	154	TXA
6107 6D 45 61	155	ADC COLBYTE
610A 8D 45 61	156	STA COLBYTE
610D	157	*****
610D	158	* Base address calculation *
610D	159	*****
610D AD 44 61	160	LDA ROWNUM
6110 48	161	PHA
6111 29 C0	162	AND #3C0
6113 85 26	163	STA GBASL
6115 4A	164	LSR
6116 4A	165	LSR
6117 05 26	166	ORA GBASL
6119 85 26	167	STA GBASL
611B 68	168	PLA
611C 85 27	169	STA GBASH
611E 0A	170	ASL
611F 0A	171	ASL
6120 0A	172	ASL
6121 26 27	173	ROL GBASH
6123 0A	174	ASL
6124 26 27	175	ROL GBASH
6126 0A	176	ASL
6127 66 26	177	ROR GBASL
6129 A5 27	178	LDA GBASH
612B 29 1F	179	AND #31F
612D 0D 41 61	180	ORA PAGE
6130 85 27	181	STA GBASH
6132	182	*****
6132	183	* Put bit status in carry *
6132	184	*****
6132 AC 45 61	185	LDY COLBYTE
6135 B1 26	186	LDA (GBASL),Y
6137 AC 46 61	187	LDY COLBIT
613A 4A	188	GETBIT
613B 88	189	DEY
613C 10 FC	190	BPL GETBIT
613E 68	191	PLA
613F A8	192	TAY
6140 60	193	RTS
6141	194	*****
6141	195	* PAGE = \$20 for Page 1 *
6141	196	* = \$40 For Page 2 *
6141	197	*****
6141 40	198	PAGE HEX 40 *Page mask
6142	199	COLNUM DFS 2
6144	200	ROWNUM DFS 1
6145	201	COLBYTE DFS 1
6146	202	COLBIT DFS 1
6147	203	COLTEMP DFS 1
6148	204	GRAPHIC DFS 1
6149	205	*****
6149	206	* Display subroutine *
6149	207	*****
	208	MSG EPZ \$00
6149 A5 00	209	DISPLAY LDA MSG *Save 0-page
614B 8D 7C 61	210	STA ZPTMP
614E A5 01	211	LDA MSG+1
6150 8D 7D 61	212	STA ZPTMP+1
6153 68	213	PLA
6154 85 00	214	STA MSG
6156 68	215	PLA
6157 85 01	216	STA MSG+1
6159 A0 00	217	LDY #0
615B E6 00	218	P1 INC MSG
615D D0 02	219	BNE P2
615F E6 01	220	INC MSG+1
6161 B1 00	221	P2 LDA (MSG),Y
6163 F0 06	222	BEQ P3
6165 20 02 C1	223	JSR PRINTGR
6168 4C 5B 61	224	JMP P1
616B A5 01	225	P3 LDA MSG+1
616D 48	226	PHA
616E A5 00	227	LDA MSG
6170 48	228	PHA
6171 AD 7C 61	229	LDA ZPTMP
6174 85 00	230	STA MSG
6176 AD 7D 61	231	LDA ZPTMP+1
6179 85 01	232	STA MSG+1
617B 60	233	RTS
617C	234	ZPTMP DFS 2
617E	235	END

MICRO

# COMPU SENSE

## CARDBOARD 3

An Economy Expansion Interface (Motherboard)

For the VIC-20® Personal Computer

The "CARDBOARD/3" is an expansion interface designed to allow the user to access more than one of the plug-in-type memory or utility cartridges now available. It will accept up to 3 RAM or ROM cartridges at once. For example:

- 16k RAM + 16k RAM + 3k RAM
- 16k RAM + 8k RAM + Super Expander
- 16k RAM + 8k RAM + Vic-Mon
- 16k RAM + 3k RAM + Programmer's Aid
- High quality T.R.W. gold plated connectors
- This board is fused
- 90 day free replacement warranty covering everything except the fuse

\$39.95

## CARDBOARD 6

An Expansion Interface for VIC-20®

- Allows memory expansion up to 40K
- Accepts up to six games
- Includes a system reset button
- All slots are switch selectable
- Daisy chain several units for even more versatility

\$87.95

TO ORDER:

P. O. BOX 18765  
WICHITA, KS 67218  
(316) 263-1095



Personal checks accepted

(Allow 3 weeks) or

C.O.D. (Add \$2)

Handling charge \$2.00

VIC-20® is a registered trademark of Commodore

Circle No. 45

# Apple Tree Electronics

## DISKS

Maxell Box of 10.5 1/4" SS-DD \$29.00

## HARDWARE

## FRANKLIN ACE 1000

The Professional Personal Computer

INTRODUCTORY PACKAGE

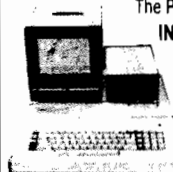

- Franklin Ace 1000
- 1-Disk drive
- Green Monitor

\$1595

## MONITORS

CALL FOR THIS MONTHS SPECIAL!

1-800-835-2246 EXT. 211

OR

702-452-5589



5130 East Charleston Blvd.  
Suite 4M  
Las Vegas, Nevada 89122



Add \$3.00 for shipping, handling and insurance. Nevada residents add 5.75% sales tax. Please include phone number.

Equipment subject to price change and availability. Call or write for price list.



# A Universal Printer Pager for APPLE



by C. Anthony Ray

---

**PAGER is an assembly-language program for the Apple II that automatically produces top and bottom margins on each page of printer output. It works with any printer, and can be switched on and off from both immediate and deferred execution modes.**

---

the size of the margin. Everything else works the same as in immediate mode.

---

**UNIVERSAL PAGER**  
requires:  
Apple with printer

---

## Background

**H**ave you ever stopped your printer because it was printer on the perforations between pages? Do you find something distasteful about program listings and outputs that run off the bottom of one page and onto the top of the next? Have you wished someone would publish an easy fix that would work for *your* Apple and *your* printer? PAGER helps you solve these problems.

## How to Use PAGER

In immediate execution mode follow these steps:

1. Type PR#n where n is the number of the slot containing your printer interface card.
2. Type BRUN PAGER.OBJ0.
3. PAGER is now connected but not active. You can do whatever you wish and PAGER will not interfere unless you type CTRL-A, change the DOS I/O hooks, or overwrite Apple's page three of memory.
4. Move your printer to the top of a new page and type CTRL-A. The

printer immediately moves down five lines.

5. Do whatever you wish, within the limits mentioned in step three — perhaps LIST a program. PAGER now produces four-line margins at both the top and bottom of each page.

6. Type CTRL-A again. PAGER automatically moves to the top of the next page and stops producing margins.

7. Go to step three.

CTRL-A is a toggle. Pressing CTRL-A once enables the margin function, and pressing CTRL-A again disables the function. To disconnect PAGER and the printer type PR#0.

To use PAGER in deferred execution mode (from within a BASIC program) you need the following lines in your program:

```
10 PRINT CHR$(4)"PR# n"  
15 PRINT CHR$(12) : REM TOP OF  
FORM CMD — EPSON  
20 PRINT CHR$(4)"BRUN PAGER.OBJ0"
```

Line 15 must contain at least one of your printer's setup commands. To toggle the function from within the program use PRINT CHR\$(1);. The semicolon prevents a carriage return from being sent to the printer, which upsets

The BASIC operating system communicates with the outside world by transmitting and receiving strings of characters. It is the responsibility of each peripheral device to provide its own routine to transmit characters to, or receive characters from, the BASIC operating system. Two pointers, one for the character-input routine (KSW or Keyboard-input SWitch, \$38-39) and one for the character-output routine (CSW or Character-output SWitch, \$36-37), are used by the BASIC operating system to locate the peripheral-driver routines that are currently being used. Normally these contain the addresses of the monitor's keyboard-input routine and the screen-output routine.

The DOS (Disk Operating System) is the driving routine for the disk. To save you from having to switch back and forth between the screen routine and the disk routine every time you want to use the disk, DOS contains an intercept routine that recognizes the commands SAVE, LOAD, etc. If a string of characters is a DOS command it is executed, and if it is not a DOS command it is passed on to the screen routine.

DOS places itself between the BASIC operating system and the screen-output routine by copying the CSW pointer to another location and

substituting the address of its intercept routine. Similarly, DOS saves the KSW pointer and replaces it with the address of one of its own routines.

Typing PR#n causes DOS to use \$Cn00 as the address of its character-output routine. \$Cn00 is the first ROM (Read Only Memory) address on the peripheral interface card in slot #n. Similarly, typing IN#n causes DOS to use \$Cn00 as the address of its character-input routine.

PAGER is an additional intercept routine that is placed between DOS and whatever the current input and output routines are. PAGER inserts itself by first finding a location in DOS that holds the addresses of the character-input and output routines. These are copied into PAGER. Now PAGER places its own intercept routine addresses into the CSW and KSW locations. The final trick is getting DOS to accept these addresses as its new character-input and output routine addresses and place its own intercept addresses in the CSW and KSW locations. Apple has provided an easy way to do this. DOS contains a subroutine that does exactly what I want and its entry point has been placed at location \$03EA. PAGER jumps to this subroutine, completing its installation.

Sometimes \$Cn00 is not the address of the character-output routine in the interface ROM. When this is the case, at least one character must be sent to the interface after the PR#n command and before connecting PAGER so that the interface can provide DOS with the correct address. This causes a problem only when PAGER is used in deferred execution mode. The best cure I've found is sending the printer setup commands to the printer before BRUNning PAGER.OBJ0.

When debugging a program using PAGER, hit RESET or type PR#0 before RUNning the program. Otherwise, starting with the second RUN, PAGER overwrites a still active copy of itself, causing the system to hang.

## How PAGER Works

After you type PR#n, DOS stores the address of the printer-driver routine. PAGER locates this address as well as the address of the character-input routine. For both DOS 3.2 and 3.3 these addresses occupy four consecutive bytes, which are found by adding \$0B96 to the address in CSW location (lines 34-40). The character-input and printer-output routine addresses are inserted in PAGER (lines 41-54) and

PAGER's intercept routine addresses are installed in DOS (lines 55-63).

The input-intercept routine (lines 73-99) looks for CTRL-A's. If one is found, FLAG is incremented by one and the least significant bit (LSB) is checked. If FLAG's LSB is 1, PAGER produces the top margin by setting MCT to TMARGIN and falling into the LOOP that outputs MCT carriage returns. If FLAG's LSB is 0, PAGER moves to the top of the next page by adding the number of lines left unprinted on the page (LCT) to the bottom margin, BMARGIN, storing the results in MCT and jumping into the LOOP (lines 100-104). The input-intercept routine must return a valid character to its caller that does not interfere with whatever is to follow — LIST, DOS command, etc. A blank is ignored by all the command interpreters, so I've chosen to return a blank. The input-intercept routine allows PAGER to work in immediate execution mode.

The output-intercept routine (lines 113-124) starts by checking for a CTRL-A and, if one is found, jumps to the routines just discussed. This provides the deferred execution mode of operation. Next PAGER checks for a carriage return. If one is found, PAGER looks to

see if FLAG's LSB is 1 by shifting it into the carry register and testing it with a conditional branch. If it is 1, the lines-left count (LCT) is decremented. If LCT is 0, all the lines to be printed on the current page have been printed and LOOP is invoked to produce MCT (which was previously set to TMARGIN + BMARGIN) carriage returns. If any of the above tests fail, the character is sent on to the printer-character-output routine.

## Customizing PAGER

You may change the top and bottom margins and the number of lines printed by changing TMARGIN, BMARGIN, and PL, respectively. If your printer uses CTRL-A as a function-selector code you may choose something else for the toggle by changing the value of CTRLA.

A few printers have their driver routines on disk instead of in ROM. If the driver routine occupies the same memory area as PAGER, PAGER may be assembled to load at another location.

You may contact the author at Cactus Computer Company, 39 Carriage Place, Urbana, IL 61801.

```

3 *****
4 *
5 * UNIVERSAL PAGER *
6 * BY C. ANTHONY RAY *
7 * *
8 *****
9     ORG $300
10 *
11 *
12 * PROGRAM CONSTANTS
13 *
14 PL     EQU 58
15 TMARGIN EQU 5
16 BMARGIN EQU 5
17 CR     EQU $8D
18 CTRLA  EQU $81
19 CSWL   EPZ $36
20 CSWH   EPZ CSWL+$1
21 KSWL   EPZ CSWH+$1
22 KSWH   EPZ KSWL+$1
23 *
24 *
25 *INITIALIZATION ROUTINE
26 *
27 *FUNCTION ACTIVE FLAG SET TO INACTIVE
28 *CHARACTER INPUT AND OUTPUT ROUTINE ADDRESSES COMPUTED
29 *PAGER INSERTED BETWEEN DOS AND CHAR INPUT AND
30 *OUTPUT ROUTINES
31 *
32     LDA #0
33     STA FLAG *INITIALIZE ACTIVITY FLAG
34     CLC *COMPUTE LOCATION OUTPUT ROUTINE
35     LDA CSWL *ADDRESS LOW ORDER BYTE
36     ADC #$96
37     STA CSWL
38     LDA CSWH *COMPUTE LOCATION OUTPUT ROUTINE
39     ADC #$0B *ADDRESS HIGH ORDER BYTE
40     STA CSWH
41     LDY #0
42     LDA (CSWL),Y*INSERT ADDRESS OUTPUT ROUTINE

```

(continued)

```

0316 8D 62 03 43 STA LOC1+1 *INTO PROGRAM - LOW ORDER BYTE
0319 8D 9B 03 44 STA LOC2+1
031C C8 45 INY
031D B1 36 46 LDA (CSWL),Y*INSERT ADDRESS OUTPUT ROUTINE
031F 8D 63 03 47 STA LOC1+2 *INTO PROGRAM - LOW ORDER BYTE
0322 8D 9C 03 48 STA LOC2+2
0325 C8 49 INY
0326 B1 36 50 LDA (CSWL),Y*INSERT ADDRESS INPUT ROUTINE
0328 8D 45 03 51 STA INPUT+1 *INTO PROGRAM - LOW ORDER BYTE
032B C8 52 INY
032C B1 36 53 LDA (CSWL),Y*INSERT ADDRESS INPUT ROUTINE
032E 8D 46 03 54 STA INPUT+2 *INTO PROGRAM - HIGH ORDER BYTE
0331 A9 44 55 LDA #INPUT *REPLACE INPUT HOOKS WITH ADDRESS
0333 85 38 56 STA KSWL *OF PAGER INPUT ROUTINE
0335 A9 03 57 LDA /INPUT
0337 85 39 58 STA KSWH
0339 A9 80 59 LDA #OUTPUT *REPLACE OUTPUT HOOKS WITH ADDRESS
033B 85 36 60 STA CSWL *OF PAGER OUTPUT ROUTINE
033D A9 03 61 LDA /OUTPUT
033F 85 37 62 STA CSWH
0341 4C EA 03 63 JMP $3EA *RECONNECT DOS
0344 64 *
0344 65 *
0344 66 *INPUT FILTER ROUTINE
0344 67 *
0344 68 *INPUT MONITORED FOR CTRL-A. EACH CTRL-A ADDS ONE TO
0344 69 *FLAG. IF LSB OF FLAG IS ONE PAGER FUNCTION IS ACTIVE
0344 70 *OTHERWISE PAGER FUNCTION IS INACTIVE
0344 71 *
0344 72 *
0344 20 FF FF 73 INPUT JSR $FFFF *GET INPUT CHARACTER
0347 C9 81 74 CMP #CTRLA *IS IT A CTRL-A?
0349 D0 28 75 BNC RETURN *NO - RETURN
034B EE 9D 03 76 LAB1 INC FLAG *YES - INCREMENT FLAG
034E A9 01 77 LDA #1
0350 2C 9D 03 78 BIT FLAG *FLAG SET?
0353 F0 1F 79 BEQ CLPAGE *NO - NEW PAGE
0355 A9 05 80 LDA #TMARGIN*YES - PRODUCE TOP MAR OUTPUT ROUTINE
0357 8D 9E 03 81 STA MCT *SET MARGIN SIZE COUNT
035A 82 *
035A 83 *
035A 84 *LOOP BELOW IS USED TO SEND CARRIAGE RETURNS TO THE
035A 85 *OUTPUT ROUTINE TO PROVIDE VERTICAL MARGIN

```

```

035A 86 *AND PAGE FUNCTIONS.
035A 87 *
035A 88 *
035A A9 8D 89 LOOP LDA #CR
035C CE 9E 03 90 DEC MCT *SEND MCT CR'S TO PRINTER
035F F0 06 91 BEQ DONE
0361 20 FF FF 92 LOC1 JSR $FFFF *GO CHAR OUTPUT ROUTINE
0364 4C 5A 03 93 JMP LOOP
0367 A9 0A 94 DONE LDA #TMARGIN+BMARGIN
0369 8D 9E 03 95 STA MCT *RESET MARGIN SIZE COUNT
036C A9 3A 96 LDA #PL
036E 8D 9F 03 97 STA LCT *RESET PRINTED LINE COUNT
0371 A9 A0 98 LDA #$AO *RETURN VALID INPUT CHAR
0373 60 99 RETURN RTS
0374 18 100 CLPAGE CLC *COMPUTE NUMBER OF LINES
0375 AD 9F 03 101 LDA LCT *LEFT ON PAGE
0378 69 05 102 ADC #BMARGIN
037A 8D 9E 03 103 STA MCT
037D 4C 5A 03 104 JMP LOOP *MOVE TO TOP OF NEW PAGE
0380 105 *
0380 106 *
0380 107 *OUTPUT FILTER ROUTINE
0380 108 *OUTPUT IS MONITORED FOR CARRIAGE RETURNS.
0380 109 *WHEN PL CARRIAGE RETURNS ARE COUNTED PAGING
0380 110 *OCCURS.
0380 111 *
0380 112 *
0380 C9 81 113 OUTPUT CMP #CTRLA *CONTROL-A?
0382 F0 C7 114 BEQ LAB1 *YES - TOGGLE FLAG
0384 C9 8D 115 CMP #CR *CARRIAGE RETURN?
0386 D0 12 116 BNE LOC2 *NO - GOTO CHAR OUTPUT ROUTINE
0388 4E 9D 03 117 LSR FLAG *FLAG SET?
038B 90 0A 118 BCC LAB2 *NO - PAGER NOT ACTIVE
038D 2E 9D 03 119 ROL FLAG *YES - RESTORE FLAG
0390 CE 9F 03 120 DEC LCT *DECREMENT LINES-TO-PRINT COUNT
0393 D0 05 121 BNE LOC2 *LAST LINE? NO-GOTO OUTPUT ROUTINE
0395 F0 C3 122 BEQ LOOP *YES - MOVE TO NEW PAGE
0397 2E 9D 03 123 LAB2 ROL FLAG *RESTORE FLAG
039A 4C FF FF 124 LOC2 JMP $FFFF *JUMP TO CHAR OUTPUT ROUTINE
039D 125 FLAG DFS 1 *ACTIVITY FLAG
039E 126 MCT DFS 1 *MARGIN SIZE COUNT
039F 127 LCT DFS 1 *LINES-TO-PRINT COUNT
03A0 128 END

```

MICRO

# DISCOUNT COMPUTER SOFTWARE ACCESSORIES

## APPLE

Retail Discount



Eliminator	\$29.95	21.00
War	24.95	18.00
Adventureland	29.95	21.00
Pirates Adventure	29.95	21.00
Golden Voyage	29.95	21.00
Magic Window	99.95	72.00
Temple of Apschai	39.95	29.00
Upper Reaches of Apschai	19.95	15.00
Curse of Ra	19.95	15.00
Midway Campaign	16.00	12.00
Hi-Res Computer Golf	29.95	21.00
OOS Boss	24.00	18.00
The Arcade Machine	44.95	33.00
Star Blazer	31.95	23.00
Choplifter	34.95	25.00
Serpentine	34.95	25.00
Deadly Secrets	34.95	25.00
Raster Blaster	29.95	21.00
Bug Attack	29.95	21.00
The Home Accountant	74.95	54.00
Snack Attack	29.95	21.00
Pig Pen	29.95	21.00
Wordrace	24.95	18.00
Rendezvous	39.95	29.00
Russki Duck	34.95	25.00
Horizon V	34.95	25.00
Sargon II	34.95	25.00

Zork I	39.95	29.00
Zork II	39.95	29.00
Deadline	49.95	36.00
Mastertype	39.95	29.00
Castle Wolfenstein	29.95	21.00
Supertext II	150.00	108.00
Softcard Premium System	775.00	600.00
Wizard and the Princess	32.95	24.00
Time Zone	99.95	72.00
Cranston Manor	34.95	25.00
Threshold	39.95	29.00
Softporn Adventure	29.95	21.00
Crossfire	29.95	21.00
Frogger	34.95	25.00
Laff Pak	34.95	25.00
Ultima II	59.95	44.00
Screenwriter II	129.95	94.00
Graphics Magician	59.95	44.00
Pie Man	29.95	21.00
Fastgammon	24.95	18.00
Congo	34.95	25.00
Goldrush	34.95	25.00
Gorgon	39.95	29.00
Beer Run	29.95	21.00
Snake Byte	29.95	21.00

Intec 32K Board \$75.00  
 APPLE Compatible Disk Drive \$265.00  
 VERBATIM/DATALIFE Disks \$26.00

## SPECIAL OFFERS

## ATARI

Retail Discount

Retail Discount



Threshold (d)	\$39.95	29.00
Snake Byte (d)	29.95	21.00
Space Eggs (d)	29.95	21.00
Bandits (d)	34.95	29.00
Color Print (d)	39.95	29.00
Canyon Climber (d)	29.95	21.00
Shooting Arcade (d) (t)	29.95	21.00
Pacific Coast Highway (d) (t)	29.95	21.00
Clowns And Balloons (d) (t)	29.95	21.00
Wordrace (d)	24.95	18.00
Andromeda (d)	34.95	25.00
Deadline (d)	49.95	36.00
Zork I (d)	39.95	29.00
Zork II (d)	39.95	29.00
Alien Swarm (d)	34.95	25.00
Action Quest (d) (t)	29.95	21.00
Ghost Encounters (d) (t)	29.95	21.00
K-Razy Shootout (c)	49.95	36.00
K-Razy Kritters (c)	49.95	36.00
Ultima I (d)	39.95	29.00
Ali Baba and Forty Thieves (d)	32.95	24.00
Deluxe Invaders (c)	39.95	29.00
Gorf (c)	49.95	36.00
Wizard of Wor (c)	49.95	36.00
Preppie (d) (t)	29.95	21.00
Tigers in the Snow (d) (t)	39.95	29.00
Ghostly Manor (d)	24.95	18.00
Raster Blaster (d)	29.95	21.00

T=Cassette  
 D=Disk  
 C=Cartridge

Rear Guard (d)	24.95	18.00
Rear Guard (t)	19.95	15.00
Caverns of Mars (d)	39.95	29.00
Atari Basic (c)	59.95	45.00
Star Raiders (c)	44.95	33.00
Centipede (c)	44.95	33.00
Pac Man (c)	44.95	33.00
Pilot (c)	79.95	60.00
Temple of Apschai (d) (t)	39.95	29.00
Upper Reaches of Apschai (t)	19.95	15.00
Curse of Ra (d)	19.95	15.00
Midway Campaign (t)	16.00	12.00
Apple Panic (d)	29.95	21.00
Track Attack (d)	29.95	21.00
Choplifter (d)	34.95	25.00
Star Blazer (d)	31.95	24.00
Wizard and the Princess (d)	32.95	24.00
Jawbreaker (d) (t)	29.95	21.00
Crossfire (d) (t)	29.95	21.00
Frogger (d) (t)	34.95	25.00
The Shattered Alliance (d)	39.95	29.00
Battle of Shiloh (d)	39.95	29.00
Submarine Commander (c)	49.95	39.00

MANY MORE PROGRAMS AVAILABLE

VISA AND MASTERCARD ACCEPTED

TERMS: Send check or money order for total purchase price, plus \$2.00 for shipping. MI residents add 4% tax. C.O.D. accepted.

© MFGS. TRADEMARK  
 Circle No. 47

**STRÖM** SYSTEMS INC.  
 P.O. Box 197  
 Plymouth, Mi. 48170  
 (313) 455-8022

WRITE OR CALL FOR FREE CATALOG  
**PHONE ORDER HOURS**  
**4 PM - 9 PM MON. - FRI.**  
 INCLUDE CARD NUMBER  
 AND EXPIRATION DATE WITH  
 CREDIT CARD ORDERS.  
 INCLUDE TYPE OF COMPUTER.

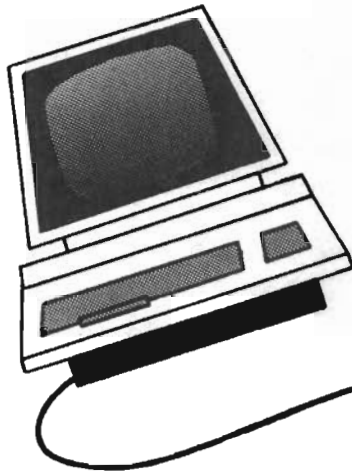

# Second Pet as Soft Printer

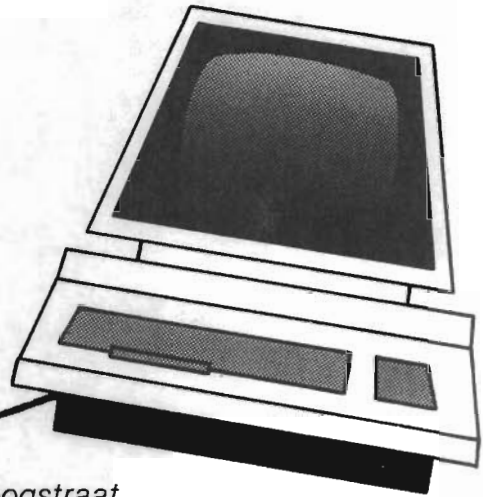

by Hans Hoogstraat

Address a second PET as IEEE device 4 — especially useful for previewing formatted printouts.

## Simulate a Printer

For those who are fortunate enough to own two PET computers, this routine allows one PET to behave like a printer, addressable as device 4 from the other PET. One application is as a soft printer for debugging formatted printouts. It eliminates the time-consuming check-out of massive hard copy printouts.

I use the 80-column screen of my SuperPET (operating in the 6502 mode) to check the output from WordPro 3, operating on my 40-column PET. I considered buying WordPro 4, which has a similar preview feature, but the reduced text capacity (150 80-column lines versus 350 40-column lines) and high price changed my mind. I simply attach the PETs together using IEEE cables and load the printer simulator into the SuperPET. This gives me great flexibility and fast checkout capabilities of WordPro's output, without wasting a lot of paper. The routine is rather simple. It demonstrates how to program the PET IEEE bus for an addressed listening device. Secondary address information is ignored but could be picked up for sub-functions.

The program is set up to wait for any key reply after every 25 lines of displayed printout. If you want, the real printer can be active at the same time. This technique could be programmed interrupt driven for both PET computers. Such an implementation opens a number of exciting applications, including two-user interactive games and downloading of programs or data from one computer to the other for shared or interactive processing.

(Listing on next page)

You may contact Mr. Hoogstraat at Box 20, Site 7, SS 1, Calgary, Alberta T2M 4N3, Canada.

```

0010;-----
0020;----- SIMULATE A PRINTER AS DEVICE 4 -----
0030;
0040; BY HANS HOOGSTRAAT
0050;-----
0060;
0070; ASSEMBLED FOR ANY ROM
0090;
0100;-----
0110;BASIC STARTUP
0120;-----
0130;
0140; .OS
0150; .BA $400
0160;
0170;10 SYS 1050
0180;
0400-000B04 0190; .BY 0 $B 4 $A 0
0403-0A00
0405-9E3130 0200; .BY $9E $31 $30 $35 $30
0408-3530
040A-000000 0210; .BY 0 0 0
0220;
0230; .BA 1050
0240;
0250;-----
0260;
0270;IEEE COMMUNICATIONS BITS.
0280;
0290;BITS 07 06 05 04 03 02 01 00
0300;...
0310;... 128 64 32 16 08 04 02 01
0320;
0330;E820 . . . . . DATA
0340;
0350;E821 X . . . . . A1N
0360;E821 . . . . X . . . . NDAC
0370;
0380;E840 X . . . . . DAV
0390;E840 . . . . . X . . . . NRPD
0400;
0410;DEVICE .DI 4
0420;
0430;-----
0440;
041A-A900 0450; LDA #$00
041C-8DE0D04 0460; STA NCHAR
041F-8DEED04 0470; STA LINES
0480;
0490;-----
0500;WAIT FOR IEEE PRINTER SELECT.
0510;-----
0520;

```

```

0530;WAIT FOR ATTENTION HIGH.
0540;
0422-78 0550PRINTER SEI
0423-AD21E8 0560 LDA E821
0426-10FA 0570 BPL PRINTER
0580;
0590;SET NDAC HIGH.
0600;
0428-AD21E8 0610 LDA E821
042B-0908 0620 ORA #S08
042D-8D21E8 0630 STA E821
0640;
0430-20B804 0650 JSR GETIEEE
0660;
0670;CHECK IF PRINTER DEVICE.
0680;
0433-C024 0690 CPY #DEVICE$20
0435-DOEB 0700 BNE PRINTER
0710;
0720;PRINTER SELECTED.
0730;
0437-F003 0740 BEQ SHKBYTE
0750;
0760;-----
0770;GET A INPUT BYTE.
0780;-----
0790;
0439-20B804 0800GETBYTE JSR GETIEEE
0810;
043C-20CF04 0820SHKBYTE JSR SHKIEEE
0830;
0840;DATA INFO ON ATTENTION LOW.
0850;
043F-8A 0860 TXA
0440-100D 0870 BPL CKDATA
0880;
0890;CHECK IF UNLISTEN.
0900;
0442-C03F 0910 CPY #S3F
0444-F0DC 0920 BEQ PRINTER
0930;
0940;CHECK FOR CLOSE.
0950;
0446-A8 0960 TAY
0447-29F0 0970 AND #SFO
0449-C9E0 0980 CMP #S0E
044B-F0D5 0990 BEQ PRINTER
1000;
1010;IGNORE SEC ADDRESSES ETC.
1020;
044D-DOEA 1030 BNE GETBYTE
1040;
1050;VALID DATA BYTE.
1060;
044F-C00D 1070CKDATA CPY #S0D
0451-D02F 1080 BNE CKDATA2
1090;
1100;ON CAR.RET INGNORE IT ON CC 80
1110;
0453-ADED04 1120 LDA NCHAR
0456-C950 1130 CMP #80
0458-D002 1140 BNE CKDATA1
1150;
045A-A000 1160 LDY #S00
1170;
045C-A900 1180CKDATA1 LDA #S00
045E-8DED04 1190 STA NCHAR
1200;
1210;ON CAR.RET INCREMENT LINE COUNT.
1220;
0461-EEEE04 1230 INC LINES
0464-ADEE04 1240 LDA LINES
0467-C919 1250 CMP #25
0469-9042 1260 BCC PRDATA
1270;
1280;END OF SCREEN, RING BELL AND WAIT.
1290;
046B-98 1300 TYA
046C-48 1310 PHA
046D-58 1320 CLI
046E-A907 1330 LDA #S07
0470-20D2FF 1340 JSR PRINT
1350;
0473-20E4FF 1360WAIT JSR GETCH
0476-F0FB 1370 BEQ WAIT

```

```

1380;
0478-78 1390 SEI
0479-68 1400 PLA
047A-A8 1410 TAY
047B-A900 1420 LDA #S00
047D-8DEE04 1430 STA LINES
0480-F02B 1440 BEQ PRDATA
1450;
1460;CONVERT ATT. TO CLEAR SCREEN.
1470;
0482-C007 1480CKDATA2 CPY #S07
0484-D00C 1490 BNE CKDATA3
1500;
0486-A900 1510 LDA #S00
0488-8DED04 1520 STA NCHAR
048B-8DEE04 1530 STA LINES
1540;
921-1
048E-A093 1550 LDY #S93
0490-D01B 1560 BNE PRDATA
1570;
1580;ACCEPT REVERSE ON AND OFF.
1590;
0492-C012 1600CKDATA3 CPY #S12
0494-F017 1610 BEQ PRDATA
0496-C092 1620 CPY #S92
0498-F013 1630 BEQ PRDATA
1640;
1650;ACCEPT ASCII ONLY $20-$5F $A0-$DF
1660;
049A-C020 1670 CPY #S20
049C-909B 1680 BCC GETBYTE
049E-C05F 1690 CPY #S5F
04A0-9008 1700 BCC ASCII
04A2-C0A0 1710 CPY #S$A0
04A4-9093 1720 BCC GETBYTE
04A6-C0E0 1730 CPY #S0E
04A8-B08F 1740 BCS GETBYTE
1750;
04AA-EEED04 1760ASCII INC NCHAR
1770;
1780;PRINT DATA.
1790;
04AD-98 1800PRDATA TYA
04AE-F089 1810 BEQ GETBYTE
1820;
04B0-58 1830 CLI
04B1-20D2FF 1840 JSR PRINT
04B4-78 1850 SEI
04B5-18 1860 CLC
04B6-9081 1870 BCC GETBYTE
1880;
1890;-----
1900;GET A BYTE FROM THE IEEE BUS.
1910;-----
1920;
1930;X ATTENTION BYTE.
1940;Y IEEE DATA BYTE.
1950;
1960;SET NRFD HIGH.
1970;
04B8-AD40E8 1980GETIEEE LDA E840
04BB-0902 1990 ORA #S02
04BD-8D40E8 2000 STA E840
2010;
2020;WAIT FOR DAV LOW.
2030;
04C0-AD40E8 2040WDAVL LDA E840
04C3-30FB 2050 BMI WDAVL
2060;
2070;SAVE ATTENTION.
2080;
04C5-AE21E8 2090 LDX E821
2100;
2110;GET BYTE AND COMPLEMENT IT.
2120;
04C8-AD20E8 2130 LDA E820
04CB-49FF 2140 EOR #SFF
04CD-A8 2150 TAY
04CE-60 2160 RTS
2170;
2180;-----
2190;COMPLETE IEEE HANDSHAKE.
2200;-----
2210;

```

Continued

# RH ELECTRONICS, INC.

COPYRIGHT © 1981 — PATENTS PENDING

566 Irelan, Buellton, CA 93427

(805) 688-2047

8:00 TO 5:00 CALIFORNIA TIME

## COMPUTER PRODUCTS

DESIGNING • MANUFACTURING  
ELECTRONIC ENGINEERING



## SUPER FAN II™

FOR YOUR APPLE II\* COMPUTER

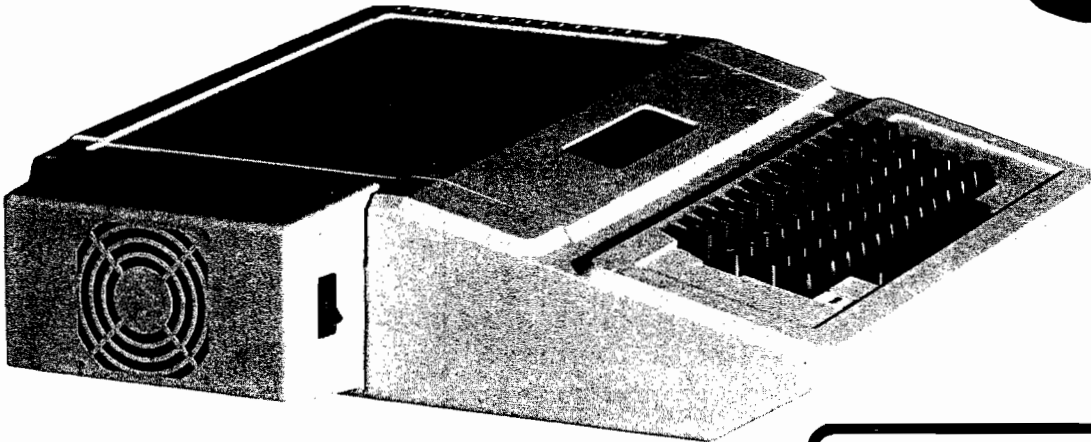

One Year Warranty

**\$74.95**

With Zener Ray™  
Protection \$109.00

MASTERCARD — VISA

### “COOL IT”

- ALSO FITS ON APPLE'S\* NEW MONITOR STAND
- RED PILOT LIGHT ON/OFF SYSTEM SWITCH
- CLIPS ON — NO HOLES OR SCREWS • REPLACEABLE SWITCH
- AVAILABLE IN 120V or 240V AND 50/60 HZ • DURABLE MOTOR
- REDUCES HEAT CAUSED BY EXTRA PLUG-IN CARDS
- SOLD WORLD WIDE • UNIQUE 1 YEAR WARRANTY
- TAN OR BLACK COLOR • QUIETEST FAN ON THE MARKET
- INCREASED RELIABILITY — SAVES DOWN TIME AND REPAIR CHARGES
- LOW NOISE DUE TO DRAWING EFFECT OF AIR THROUGH YOUR COMPUTER AND SPECIAL FAN AND MOTOR DESIGN
- TWO EXTRA 120V OUTLETS FOR MONITOR AND ACCESSORIES TURN ON WHEN YOU TURN ON YOUR FAN (NOT AVAILABLE ON 240V MODEL)

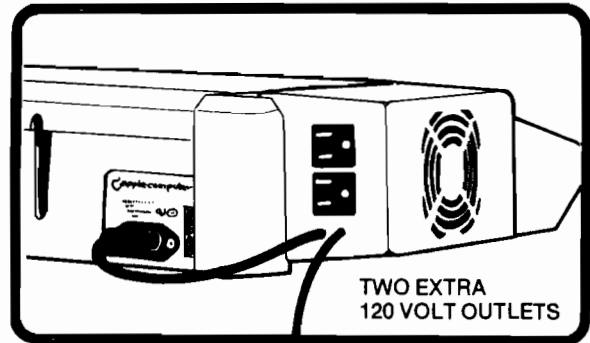

**SUPER FAN II™ WITH ZENER RAY OPTION \$109.00**

## ZENER RAY™ TRANSIENT VOLTAGE SUPPRESSOR

OUR BUILT IN ADVANCED DESIGN UNIT GIVES  
**DRAMATIC COST SAVINGS** — STOPS ANNOYING DOWN TIME  
**INSURANCE FROM VOLTAGE SPIKES - GLITCHES**

**DANGEROUS VOLTAGE SPIKES CAN JEOPARDIZE YOUR COMPUTER SYSTEMS**  
**PROTECT COMPUTER - DISK DRIVE - PRINTER AND MONITOR**

NO CUTTING WIRES • WON'T VOID WARRANTY, JUST PLUG IN SUPERFAN II WITH ZENER RAY

OTHER PRODUCTS BY **RH ELECTRONICS, INC.**

**SUPER RAM II™** 16K RAM CARD FOR YOUR APPLE II. 2 YEAR WARRANTY \$125

**GUARDIAN ANGEL™** AN UNINTERRUPTABLE POWER SOURCE \$595

**12 VOLT TRANSVERTER** 12 VOLT — RUNS YOUR APPLE II COMPUTER AND  
AND 5¼" DRIVE FROM YOUR CIGARETTE LIGHTER \$149

\*Registered trademarks of Apple Computer Inc.

**DEALER INQUIRIES INVITED**

new address  
phone number

Phone  
(603) 889-1370

Send correspondence to:  
P.O. Box 6502  
110 Northern Ave.  
Northwood Executive Park  
Amherst, NH 03042

```

2220;SET NRFD LOW.
2230;
04CF-AD40E8 2240SHKIEEE LDA E840
04D2-29FD 2250 AND #3FF-02
04D4-8D40E8 2260 STA E840
2270;
2280;SET NDAC HIGH.
2290;
04D7-AD21E8 2300 LDA E821
04DA-0908 2310 ORA #908
04DC-8D21E8 2320 STA E821
2330;
2340;WAIT FOR DAV HIGH.
2350;
04DF-AD40E8 2360WDAVH LDA E840
04E2-10FB 2370 BPL WDAVH
2380;
2390;SET NDAC LOW.
2400;
04E4-AD21E8 2410 LDA E821
04E7-29F7 2420 AND #3FF-08
04E9-8D21E8 2430 STA E821
04EC-60 2440 RTS
2450;
2460;-----
2470;
2480E820 .DI $E820
2490E821 .DI $E821
2500E840 .DI $E840
2510;
2520PRINT .DE $FFD2
2530GETCH .DE $FFE4
2540;
04ED- 2550NCHAR .DS 1
04EE- 2560LINES .DS 1
2570 .EN

LABEL FILE:

DEVICE 0004 PRINTER 0422
GETBYTE 0439 SHKBYTE 043C

```

```

CKDATA 044F CKDATA1 045C
WAIT 0473 CKDATA2 0482
CKDATA3 0492 ASCII 04AA
PRDATA 04AD GETIEEE 04B8
WDAVL 04C0 SHKIEEE 04CF
WDAVH 04DF E820 E820
E821 E821 E840 E840
*PRINT FFD2 *GETCH FFE4
NCHAR 04ED LINES 04EE

Hexadecimal dump Printer simulator.
-----
0400 00 0B 04 0A 00 9E 31 30
0408 35 30 00 00 00 AA AA AA
0410 AA AA AA AA AA AA AA AA
0418 AA AA A9 00 8D ED 04 8D
0420 EE 04 78 AD 21 E8 10 FA
0428 AD 21 E8 09 08 8D 21 E8
0430 20 B8 04 C0 24 D0 EB F0
0438 03 20 B8 04 20 CF 04 8A
0440 10 0D C0 3F F0 DC A8 29
0448 F0 C9 E0 F0 D5 D0 EA C0
0450 0D D0 2F AD ED 04 C9 50
0458 D0 02 A0 00 A9 00 8D ED
0460 04 EE EE 04 AD EE 04 C9
0468 19 90 42 98 48 58 A9 07
0470 20 D2 FF 20 E4 FF F0 FB
0478 78 68 A8 A9 00 8D EE 04
0480 F0 2B C0 07 D0 0C A9 00
0488 8D ED 04 8D EE 04 A0 93
0490 D0 1B C0 12 F0 17 C0 92
0498 F0 13 C0 20 90 9B C0 5F
04A0 90 08 C0 A0 90 93 C0 E0
04A8 B0 8F EE ED 04 98 F0 89
04B0 58 20 D2 FF 78 18 90 81
04B8 AD 40 E8 09 02 8D 40 E8
04C0 AD 40 E8 30 FB AE 21 E8
04C8 AD 20 E8 49 FF A8 60 AD
04D0 40 E8 29 FD 8D 40 E8 AD
04D8 21 E8 09 08 8D 21 E8 AD
04E0 40 E8 10 FB AD 21 E8 29
04E8 F7 8D 21 E8 60

```

**MICRO**

# VIC-20\*

# SOFTWARE SPECIALS

# CBM-64\*

**NEW!**  
**CARTRIDGE GAMES FROM TRONIX**

**SCORPION ..... \$34.95**

Full 4-way scrolling, fast action predator game where it's you against killer frogs, slimy worms, stalker flies, dragons and hatcher pods. With 32 levels of play.

**GOLD FEVER .. \$29.95**

Explore a deadly mine searching for valuable gold deposits. Avoid roaming mine carts, rolling boulders and a crazy claim jumper! With 9 levels of play.

**DEADLY SKIES ..... \$29.95**

Frenetic, fast paced, action-packed game where you are the Rebel fighter attacking the hostile military base. Avoid S.A.M.'s smart bombs and deadly radioactive clouds! Over 10 levels of play.

From Interesting Software  
Cassette ..... \$15.95  
ALL MACHINE CODE!



**QUACKERS**

Bring the fun of the shooting gallery into your home. With music and colorful graphics.

**CBM-64 & VIC-20 MINI-MONITOR**

All machine code monitor which will disassemble code, do text dump, move memory, hex to decimal and decimal to hex conversion as well as a mini-assembler!

**VIC-20 version requires 8K expansion.**

Cassette ..... \$24.95  
Disk ..... \$29.95

**CREATIVE SOFTWARE GAMES ON CARTRIDGE**

CHOPLIFTER ..... \$39.95  
SERPENTINE ..... \$39.95  
APPLE PANIC ..... \$39.95  
ASTROBLITZ ..... \$39.95  
TRASHMAN ..... \$39.95

**Stellar Triumph**

Great new all machine code game for your CBM-64. One or two player game with all the arcade sound and graphics! Fantastic space war game with many options.

From H.A.L. Labs ... tape or disk ..... \$24.95

**Dust Covers**

Water resistant  
Attractive brown canvas **\$7.95**

**KIDS & THE VIC**

Great new book to add to your library.  
only ..... \$14.95

**INTERESTING SOFTWARE**  
21101 S. Harvard Blvd., Torrance, CA 90501  
(213) 328-9422

Visa MC Check Money Order Add \$2.00 Postage & Handling  
CA residents add appropriate sales tax Dealer Inquiries Invited

# MULTIC A Multi-Column Printer for AIM

by Joel Swank

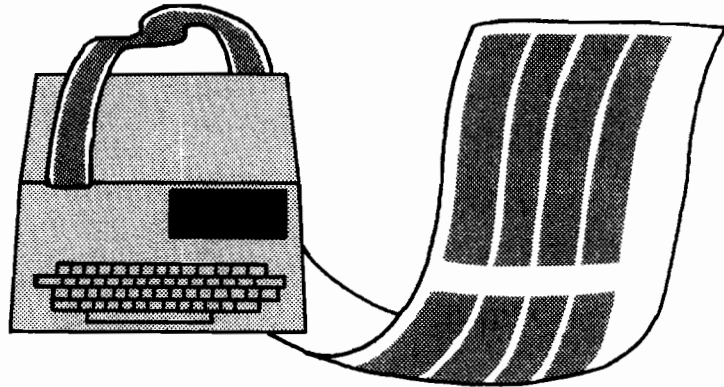

---

**Print AIM listings the full width of your printer  
with this machine-language printer driver.**

---

## MULTIC

requires:

AIM with line printer

---

When I purchased my AIM 65, I was skeptical about the usefulness of the little onboard 20-column printer. I wondered what use it could have since I already had a full-sized printer. I soon realized how handy it is to have that small printer available since most AIM output is formatted to fit its 20-column line length. I even found it convenient to design some of my own programs to match the 20-column format. AIM's printer is fine for short- to medium-sized listings, but is inappropriate for long ones. I still send large listings to my full-size printer; but printing a 20-column listing on my printer, which can handle lines up to 132 columns long, wastes paper and time. To solve this problem I wrote MULTIC.

MULTIC inputs a single column of print from the active input device (AID) and reformats it into two to nine columns, side by side, on the page. This saves a lot of paper. I originally designed MULTIC to reformat 20-character lines into pages 96 characters across with four columns; I decided MULTIC would be more useful if I made it as general as possible. MULTIC prompts for all information needed to describe the input and output. It must have enough RAM available to store one entire page of data. This RAM, called the page buffer, is allocated by the user and its size varies with the size of the output page.

## Operation

MULTIC prompts for the following information:

**FROM** = The start of the page buffer in hexadecimal. The default is the end of MULTIC.

**TO** = The end of the page buffer in hexadecimal. The default is \$FFFF.

**INPUT LINE LENGTH** = The maximum size of the input line in decimal. This is the width of one column on the output page. Input lines longer than this are split into two or more lines. Lines shorter than this are extended with blanks to keep the columns aligned. Minimum is 10, default is 20.

**NUMBER OF COLUMNS** = The number of columns of the input data to print across the output page. Default is 3.

**SPACES BETWEEN COLUMNS** = The number of blanks to insert between columns on the output page. Default is 5. The number of print columns needed to print a given format can be determined by the formula:

$$C * I + (C - 1) * S$$

where C is the number of columns, I is the input line length, and S is the number of spaces between columns. The result of this calculation must not exceed the column width of the printer that is to print the output.

**LINES PER PAGE** = The number of print lines per page. Maximum is 255, default is 60.

**LINES BETWEEN PAGES** = The number of lines to skip between pages. This number, plus the lines per page, should match the total number of lines the printer can print on one page of paper. If zero is entered for this prompt,

MULTIC will send a form feed (\$C) between pages instead of skipping lines to the top of the page. Default is 6.

**IN** = The standard AIM prompt to open the input device. The input file must be terminated with a control Z (\$1A) so MULTIC can detect the end of the file.

**OUT** = The standard AIM prompt to open the output device. MULTIC will write the output to the AOD a page at a time. If the tape is the output device, it will be closed when MULTIC finishes.

## Errors

Any errors detected during input of parameters are flagged with the standard AIM ERROR message and the prompt re-issued. The MEMORY OVERFLOW error occurs when the page buffer fills before an entire page has been read in. The program must be restarted with more RAM allocated to the page buffer or a smaller page format.

Recently I used MULTIC to print a complete disassembly of the 8K AIM BASIC ROM, which amounts to about 4500 lines. This would take over 60 feet of paper on the AIM printer; I printed it five columns across the page and it took only 11 pages!

## Modifications

Since MULTIC uses the AIM AID and AOD, the data to be printed must be stored on an auxiliary device. MULTIC is separated into subroutines so it can be modified to work directly from the user output port and to send output directly to the printer. The initialization would have to be executed as part of the open routine, and the subroutines REDBUF and REDCOL rewritten to execute as the user output routine. The output calls would have to be changed to call the printer driver routines directly.

(Listing on next page)

---

You can contact the author at 12550 SW Colony #3, Beaverton, OR 97005.



Listing 1: MULTIC Assembly Listing

```

MULTIC : MULTI COLUMN PRINT FORMATER FOR AIM
:
: FUNCTION : TO REFORMAT A TEXT FILE FOR PRINTING
: AS MULTI COLUMNS ON A PAGE. ALL INFO IS INPUT WITH
: PROMPTS.
:
.OPT GEN
:
: AIM SUBROUTINES
WHEREI =#E848 :OPEN INPUT FILE
WHEREO =#E871 :OPEN OUTPUT FILE
OUTALL =#E98C :SEND CHARACTER TO AOD
INALL =#E993 :GET CHAR FROM AID
OUTPUT =#E97A :SEND CHAR TO DISPLAY
CRLF =#E9F0 :SEND CR & LF TO AOD
COMIN =#E1A1 :RETURN TO MONITOR
CKER00 =#E394 :DISPLAY 'ERROR'
DU11 =#E50A :CLOSE TAPE FILE
RDRUB =#E95F :INPUT CHAR WITH DELETE
RCHEK =#E907 :CHECK FOR INTERRUPT
FROM =#E7A3 :DISPLAY 'FROM=' AND GET AOD
TO =#E7A7 :DISPLAY 'TO=' AND GET AOD
:
: ZERO PAGE
START =0 :EIGHT BUFFER POINTERS
LINLEN =#10 :CHARACTERS PER COLUMN
INTSPA =#11 :SPACES BETWEEN COLUMNS
COLUMN =#12 :NUMBER OF COLUMNS
LINES =#13 :LINES PER PAGE
SKPLIN =#14 :LINES TO SKIP AT END OF PAGE
EOFLAG =#15 :NON-ZERO FLAGS END OF FILE
LCOUNT =#16 :TEMP LINE COUNT
CCOUNT =#17 :TEMP CHAR COUNT
DCOUNT =#18 :DECIMAL CONVERSION TEMP
DECTMP =#19 :DECIMAL CONVERSION TEMP
POINT =#1A :BUFFER FILL POINTER
BUFBEG =#1C :BEGINNING OF BUFFER
BUFEND =#1E :END OF BUFFER
SAUY =#20 :TEMP SAVE FOR Y
SPLFLG =#21 :SPLIT LINE FLAG
:
: EQUATES
LF =10
FF =12
CR =13
CTLZ =#1A
LINMAX =20
:
: DEFAULTS FOR PARMS
LENDEF =20 :WIDTH OF COLUMN
INTDEF =5 :SPACE BETWEEN COLUMNS
COLDEF =3 :NUMBER OF COLUMNS
LINDEF =60 :LINES PER PAGE
SKPDEF =6 :LINES BETWEEN PAGES
:
: AIM RAM
CKSUM =#A41E
CURAD =#A41C
*=#200
0200 20 F2 03 MULTIC JSR DEFALT :SET DEFAULTS
0203 20 4F 03 JSR GETPRM :INPUT INFO
0206 20 48 E8 JSR WHEREI :OPEN INPUT
0209 20 71 E8 JSR WHEREO :OPEN OUTPUT FILE
020C A9 00 LDA #0 :CLEAR SPLIT FLAG
020E 85 21 STA SPLFLG
0210 20 24 03 PAGLUP JSR ZEROPT :CLEAR POINTERS
0213 20 48 02 JSR REDBUF :FILL PAGE BUFFER
0216 : PRINT THE BUFFER
0216 A5 13 LDA LINES :GET LINE COUNT
0218 85 16 STA LCOUNT
021A A5 01 LINLUP LDA START+1 :END OF FILE?
021C F0 1C BEQ ALLDUN :YES, QUIT
021E 20 D7 02 JSR PRTLIN :PRINT A LINE
0221 C6 16 DEC LCOUNT :COUNT IT
0223 D0 F5 BNE LINLUP :NEXT LINE
0225 A6 14 LDX SKPLIN :GET LINES TO SKIP
0227 F0 08 BEQ PAGUP :NONE, NEXT PAGE
0229 20 F0 E9 SKPLUP JSR CRLF :SKIP A LINE
022C CA DEX
022D D0 FA BNE SKPLUP
022F F0 05 BEQ CKEND

```

Listing 1 (Continued)

```

0231 A9 0C PAGUP LDA #FF :SEND FORM FEED
0233 20 BC E9 JSR OUTALL
0236 A5 15 CKEND LDA EOFLAG :END OF PAGE - ANY MORE DATA?
0238 F0 D6 BEQ PAGLUP :YES, CONTINUE
:
023A A9 1A ALLDUN LDA #CTLZ :SEND EOF CHAR
023C 20 BC E9 JSR OUTALL
023F 20 F0 E9 JSR CRLF
0242 20 F0 E9 JSR CRLF :AND 2 RETURNS
0245 20 0A E5 JSR DU11 :CLOSE IF TAPE FILE
0248 4C A1 E1 JMP COMIN
:
024B : END OF MAINLINE
:
024B : SUBROUTINES FOLLOW
:
024B : REDBUF : READ PAGE BUFFER FULL WITH REQUESTED
024B : NUMBER OF COLUMNS OF DATA
:
024B A4 12 REDBUF LDY COLUMN :GET COLUMN COUNT
024D A2 00 LDX #0 :POINT TO FIRST BUFFER POINTER
024F 20 66 02 RDBLUP JSR REDCOL :READ A COLUMN
0252 A5 15 LDA EOFLAG :END?
0254 D0 0F BNE ROBEND :YES, QUIT
0256 88 DEY :COUNT
0257 F0 0C BEQ ROBEND :QUIT IF COUNT ZERO
0259 A5 1A LDA POINT :COPY POINT TO
025B 95 02 STA START+2,X :NEXT START
025D A5 1B LDA POINT+1
025F 95 03 STA START+3,X
0261 E8 INX
0262 E8 INX :NEXT POINTER
0263 D0 EA BNE RDBLUP :NEXT BUFFER
0265 60 ROBEND RTS
:
0266 : REDCOL : READ A COLUMN INTO THE BUFFER
:
0266 A9 00 REDCOL LDA #0 :CLEAR COUNTS
0268 85 17 STA CCOUNT
026A 85 16 STA LCOUNT
:
026C 20 93 E9 NEXTCH JSR INALL :GET A CHARACTER
026F C9 0A CMP #LF :LINE FEED?
0271 F0 F9 BEQ NEXTCH :YES, IGNORE IT
0273 C9 0C CMP #FF :FORM FEED?
0275 F0 F5 BEQ NEXTCH :YES, IGNORE IT
0277 C9 00 CMP #CR :END OF LINE?
0279 D0 0A BNE NOCR :NOPE
027B A5 21 LDA SPLFLG :FOLLOWING SPLIT LINE?
027D F0 1B BEQ EOL :NO, END OF LINE
027F A9 00 LDA #0 :YES, CLEAR FLAG
0281 85 21 STA SPLFLG
0283 F0 E7 BEQ NEXTCH :AND IGNORE IT
0285 20 AF 02 NOCR JSR STOCH :SAVE IT
0288 C9 1A CMP #CTLZ :END OF FILE?
028A F0 20 BEQ EOF :YES
028C A9 00 LDA #0 :CLEAR SPLIT FLAG
028E 85 21 STA SPLFLG
0290 E6 17 INC CCOUNT :COUNT CHAR
0292 A5 17 LDA CCOUNT :GET MAX LENGTH
0294 C5 10 CMP LINLEN :AT MAX?
0296 90 D4 BCC NEXTCH :NO, GET ANOTHER
0298 85 21 STA SPLFLG :FLAG SPLIT LINE
029A A9 00 LDA #CR :YES, INSERT CR
029C 20 AF 02 JSR STOCH
029E E6 16 INC LCOUNT :COUNT LINE
02A1 A9 00 LDA #0
02A3 85 17 STA CCOUNT :CLEAR CHAR COUNT
02A5 A5 16 LDA LCOUNT :GET LINE COUNT
02A7 C5 13 CMP LINES :AT LINE LIMIT?
02A9 D0 C1 BNE NEXTCH :NO, GET ANOTHER
02AB 60 RTS
:
02AC 85 15 EOF STA EOFLAG :SIGNAL END
02AE 60 RTS
:
02AF : STOCH : STORE ONE CHARACTER IN BUFFER
:
02AF 84 20 STOCH STY SAUY :SAVE Y
02B1 A0 00 LDY #0
02B3 91 1A STA (POINT),Y :STORE CHAR
02B5 D1 1A CMP (POINT),Y :DID IT TAKE?
02B7 D0 16 BNE MEMERR :NOPE

```

(continued)

another  
**FLEXIDUCT**<sup>®</sup> OFFICE  
SAFETY PRODUCT



When you  
least expect it,  
**ZAP!!!**

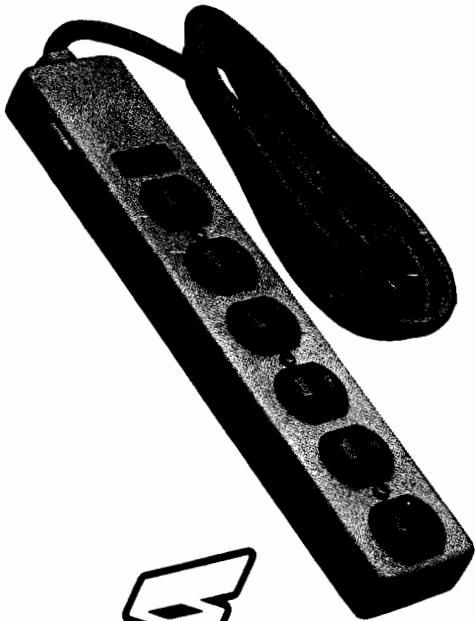

In a few millionths of a second, common electrical surges and spikes can enter your data processing equipment and cause memory loss, false logic and misregistration. Surges very often do permanent damage to microcircuitry.

**FLEXIDUCT** Surge Suppressors catch surges and spikes before they have a chance to enter your equipment. In billionths of a second (Nanoseconds), **FLEXIDUCT** Surge Suppressors dissipate surges and spikes from any side of the line (most protect only one side).

The multi-outlet unit is ideally suited to the computerized workstation. It gives you the advantage of circuit breaker protection with plenty of outlets for data processor and peripheral equipment.

No computer should be without the protection of a **FLEXIDUCT** Surge Suppressor...**especially yours!** Write or call for further information. Available from office products retailers.

**FLEXIDUCT**<sup>®</sup> Surge Suppressors

a product of Winders & Geist, Inc. P.O. Box 83088 Lincoln, NE 68501 402/474-3400

Listing 1 (Continued)

```

02B9 A4 20      LDY SAUY      :RESTORE Y
02B8 E6 1A      INC POINT      :YES, BUMP POINTER
02BD D0 02      BNE NOCY1
02BF E6 1B      INC POINT+1
02C1 48          NOCY1 PHA
02C2 38          SEC
02C3 A5 1E      LDA BUFEND     :CHECK FOR END OF BUFFER
02C5 E5 1A      SBC POINT
02C7 A5 1F      LDA BUFEND+1
02C9 E5 1B      SBC POINT+1
02CB 90 02      BCC MEMERR
02CD 68          PLA
02CE 60          RTS

02CF A0 63      MEMERR LDY #MEMMSG-LITS
02D1 20 18 04   JSR KEPIX      :DISPLAY MEMORY MESSAGE
02D4 4C A1 E1   JMP COMIN      :RETURN TO AIM

02D7          PRTLIN : PRINT A LINE FROM PAGE BUFFER

02D7 20 07 E9   PRTLIN JSR RCHEK :CHECK FOR INTERRUPT
02DA A9 00      LDA #0         :CLEAR COUNT
02DC 85 17      STA CCOUNT   :GET COLUMN COUNT
02DE A4 12      LDY COLUMN     :GET COLUMN COUNT
02E0 A2 00      LDX #0         :CLEAR POINTER INDEX
02E2 F0 16      BEQ PRCHR

02E4 A5 17      PRTLUP LDA CCOUNT :SEND SPACES TO NEXT COLUMN
02E6 C5 10      SPACLP CMP LINLEN :AT LINE LENGTH?
02E8 F0 09      BEQ ISPACE    :YES, QUIT
02EA 20 3A 03   JSR BLANK     :SEND A BLANK
02ED E6 17      INC CCOUNT   :COUNT
02EF A5 17      LDA CCOUNT   :GET COUNT
02F1 D0 F3      BNE SPACLP    :REPEAT

02F3 20 3F 03   ISPACE JSR SPCOUT :SEND INTER-COLUMN GAP
02F6 A9 00      LDA #0         :CLEAR COUNT
02F8 85 17      STA CCOUNT
02FA A1 00      PRCHR LDA (START,X) :GET A CHAR
02FC F6 00      INC START,X   :BUMP POINTER
02FE D0 02      BNE NOCY2
0300 F6 01      INC START+1,X
0302 C9 0D      NOCY2 CMP #CR   :END OF LINE?
0304 F0 0B      BEQ COLEND    :YES
0306 C9 1A      CMP #CTLZ     :END OF PAGE?
0308 F0 12      BEQ LINEND    :YES
030A 20 BC E9   JSR OUTALL    :SEND IT
030D E6 17      INC CCOUNT   :COUNT CHAR
030F D0 E9      BNE PRCHR     :NEXT

0311 88          COLEND DEY :COUNT COLUMN
0312 F0 0C      BEQ CROUT     :QUIT ON LAST
0314 E8          INX
0315 E8          INX          :NEXT POINTER
0316 B5 01      LDA START+1,X :ANY DATA?
0318 D0 CA      BNE PRTLUP    :YES
031A F0 04      BEQ CROUT     :NO

031C A9 00      LINEND LDA #0   :MARK THIS COLUMN FINISHED
031E 95 01      STA START+1,X
0320 20 F0 E9   CROUT JSR CRLF  :SEND CR & LF
0323 60          RTS

0324          ZEROPT : INIT POINTERS FOR NEXT PAGE

0324 A2 0F      ZEROPT LDX #15
0326 A9 00      LDA #0
0328 95 00      ZPLUP STA START,X :CLEAR POINTER TABLE
032A CA          DEX
032B 10 FB      BPL ZPLUP
032D A5 1C      LDA BUFBEQ    :INIT FIRST POINTER
032F 85 00      STA START
0331 85 1A      STA POINT
0333 A5 1D      LDA BUFBEQ+1
0335 85 01      STA START+1
0337 85 1B      STA POINT+1
0339 60          RTS

033A          BLANK : SEND SPACE TO AOD

033A A9 20      BLANK LDA # ' '
033C 4C BC E9   JMP OUTALL

0218 033F      SPCOUT : SEND SPACES TO NEXT COLUMN
    
```

Listing 1 (Continued)

```

033F A5 11      SPCOUT LDA INTSPA :GET SPACE COUNT
0341 F0 0B      BEQ SPCDUN    :NONE, SKIP IT
0343 48          PHA
0344 20 3A 03   SPCLUP JSR BLANK :SEND A BLANK
0347 C6 11      DEC INTSPA    :COUNT
0349 D0 F9      BNE SPCLUP    :REPEAT TILL ZERO
034B 68          PLA
034C 85 11      STA INTSPA    :RESTORE SPACE COUNT
034E 60          SPCDUN RTS

034F          GETPRM : PROMPT FOR AND INPUT PARAMETERS

034F 20 A3 E7   GETPRM JSR FROM   :GET BUFFER START
0352 B0 FB      BCS GETPRM
0354 AD 1E A4   LDA CKSUM     :ANY ENTERED?
0357 D0 0A      BNE GTEND    :NO, USE DEFAULT
0359 AD 1C A4   LDA CURRAD    :MOVE ADDRESS TO
035C 85 1C      STA BUFBEQ    :BEGIN POINTER
035E AD 1D A4   LDA CURRAD+1
0361 85 1D      STA BUFBEQ+1

0363 20 A7 E7   GTEND JSR TO       :GET END ADDRESS
0366 B0 FB      BCS GTEND
0368 AD 1E A4   LDA CKSUM     :ANY SPECIFIED?
036B D0 0A      BNE GTLL     :NO, USE DEFAULT
036D AD 1C A4   LDA CURRAD    :YES, MOVE IT TO
0370 85 1E      STA BUFEND    :END POINTER
0372 AD 1D A4   LDA CURRAD+1
0375 85 1F      STA BUFEND+1

0377 20 F0 E9   GTLL JSR CRLF   :NEW LINE
037A A0 00      RELL LDY #LLMSG-LITS
037C 20 18 04   JSR KEPIX     :REQUEST LINE LENGTH
037F 20 24 04   JSR INDEC     :INPUT A DECIMAL NUMBER
0382 B0 F6      BCS RELL      :RETRY IF ERROR
0384 AE 1E A4   LDX CKSUM     :ANY?
0387 D0 0C      BNE GTCOL    :NO
0389 C9 0A      CMP #10       :MINIMUM OF 10
038B B0 06      BCS STLEN    :NO
038D 20 94 E3   JSR CKERR00   :ERROR MSG
0390 4C 7A 03   JMP RELL      :RETRY
0393 85 10      STLEN STA LINLEN

0395 A0 2B      GTCOL LDY #COLMSG-LITS
0397 20 18 04   JSR KEPIX     :REQUEST # OF COLUMNS
039A 20 24 04   JSR INDEC     :GET REPLY
039D B0 F6      BCS GTCOL    :RETRY ON ERROR
039F AE 1E A4   LDX CKSUM     :ANY?
03A2 D0 10      BNE GTSP     :NO
03A4 C9 01      CMP #1         :MINIMUM OF 1
03A6 90 04      BCC COLERR   :NO
03A8 C9 09      CMP #9         :MAX OF 8
03AA 90 06      BCC STCOL    :NO
03AC 20 94 E3   COLERR JSR CKERR00 :ERROR MSG
03AF 4C 95 03   JMP GTCOL
03B2 85 12      STCOL STA COLUMN :SAVE IT

03B4 A0 13      GTSP LDY #SPMSG-LITS
03B6 20 18 04   JSR KEPIX     :REQUEST SPACE BETWEEN COLUMNS
03B9 20 24 04   JSR INDEC     :GET REPLY
03BC B0 F6      BCS GTSP     :RETRY ERROR

03BE AE 1E A4   LDX CKSUM     :ANY?
03C1 D0 02      BNE GTLIN    :NO
03C3 85 11      STA INTSPA    :SAVE IT

03C5 A0 3E      GTLIN LDY #LINMSG-LITS
03C7 20 18 04   JSR KEPIX     :REQUEST LINES PER PAGE
03CA 20 24 04   JSR INDEC     :GET REPLY
03CD B0 F6      BCS GTLIN    :NO
03CF AE 1E A4   LDX CKSUM     :ANY?
03D2 D0 0C      BNE GTPER    :NO
03D4 C9 02      CMP #2         :MINIMUM OF 2
03D6 B0 06      BCS STPER    :NO
03D8 20 94 E3   JSR CKERR00   :ERROR MSG
03DB 4C C5 03   JMP GTLIN     :RETRY
03DE 85 13      STPER STA LINES  :SAVE IT

03E0 A0 4E      GTPER LDY #PERMSG-LITS
03E2 20 18 04   JSR KEPIX     :REQUEST LINES BETWEEN PAGES
03E5 20 24 04   JSR INDEC     :GET REPLY
03E8 B0 F6      BCS GTPER    :RETRY ON ERROR
03EA AE 1E A4   LDX CKSUM     :ANY?
03ED D0 02      BNE GTRT     :NO
03EF 85 14      STA SKPLIN  :SAVE IT
03F1 60          GTRT RTS
    
```

(continued)

# Applesoft

## as easy as 1-2-3-4

APPLESOFT—as easy as 1, 2, 3, 4! Sensible Software has the tools you need to make programming in Applesoft as easy as 1, 2, 3, 4! Our utility programs assist you from the time you start designing your program all the way through to adding the final touches to your masterpiece. Specific areas where we help you are:

**1. DESIGN...** Our APLUS utility gives you the extra, 'structured programming' commands you need to design clear, easy-to-follow Applesoft programs. APLUS will even automatically indent your program listings to clarify the logic flow.

And you don't need to have APLUS to run the final program. APLUS includes a command to convert APLUS keywords into standard Applesoft commands.

'Named' subroutines, full 'if..then..else' control, case statements, a variety of loops—all this and more is yours for only \$39.95.

### 3. FORMATTING...

Our BUILD USING program is a machine language subroutine that can easily be added to your Applesoft programs to give you complete control over how your numbers and strings are printed. BUILD USING gives you *more* number-formatting options than other 'Print Using' programs. You control the number of decimal places, additional 'fill' characters, and many other parameters.

BUILD USING also goes beyond the competition in a variety of other ways. The 'CALL' command is used to access BUILD USING to leave the '&' free for other subroutines (e.g. a sorting program). Errors are handled more intelligently because numbers are formatted in memory before you print. BUILD USING also has three levels of error trapping to tell you ahead of time if a number won't fit into a format. BUILD USING can also help you format strings (e.g. 'JOHN DOE' can be easily printed as 'DOE, J.'). BUILD USING even gives you four choices about how you want it added to your Applesoft program.

BUILD USING is affordably priced at \$30.00.

**2. TYPING...** Our EDIT-SOFT program line editor takes the aggravation out of typing in your program. This is a full-featured line editor that helps you easily find, insert, and delete individual characters in an Applesoft program line without needing to retype the entire line.

Of course, EDIT-SOFT gives you many additional features. With EDIT-SOFT, you can:

- splice two lines together
- search your entire program for a variable or a string with a single command
- automatically generate line numbers as you enter a program
- define keyboard macros
- automatically count characters inside quotes (terrific for formatting Print statements).

All this for only \$39.95.

### 4. FINISHING UP...

Our BASIC Enhanced Software Tools (B.E.S.T.) is invaluable for getting the last few bugs out and for putting the finishing touches into your programs.

For example, when you suspect that you gave two different variables the same name or when you don't understand how you suddenly ended up in your 'get an answer' subroutine—B.E.S.T. can help! B.E.S.T. produces several cross-reference reports that identify where variables are defined and used in your program. Other reports are available to point out all the places in your program that can branch to or 'GOTO' a specified line number.

When you are finishing up, B.E.S.T. provides numerous 'tuning' options that optimize the performance of your program by making it smaller and faster. B.E.S.T. can selectively: remove remarks, shorten variable names, and even squeeze short lines together. It all adds up to more free memory for your data.

Best yet, B.E.S.T. is only \$40.00.

## a special offer

All four of the above programs are now available in a special combination package for only \$99.95— at a savings of 33% over the individual prices!

These programs are supplied on diskette and will work on Apple //e, Apple II Plus, and equivalent computers. These programs will also work on older mode Apple II computers equipped with either an Applesoft Firmware Card, a RAM expansion card, or an Apple Language Card.

APPLE and APPLESOFT are trademarks of APPLE COMPUTER, INC.

 **Sensible Software, Inc.**

6619 Penham Drive West Bloomfield, MI 48033  
(313) 399-8877  
VISA & Mastercard Welcome  
Please add \$1.25 postage and handling per diskette.

Listing 1 (Continued)

```

03F2          :  DEFAULT : INIT DATA AREAS WITH DEFAULTS

03F2 A9 14    DEFAULT LDA #LENDEF
03F4 85 10    STA LINLEN
03F6 A9 05    LDA #INTDEF
03F8 85 11    STA INTSPA
03FA A9 03    LDA #COLDEF
03FC 85 12    STA COLUMN
03FE A9 3C    LDA #LINDEF
0400 85 13    STA LINES
0402 A9 06    LDA #SKPDEF
0404 85 14    STA SKPLIN
0406 A9 F9    LDA #KPGBUF      :PAGBUF IS DEFAULT FOR
0408 85 1C    STA BUFBEG      :BUFFER BEGIN
040A A9 04    LDA #)PAGBUF
040C 85 1D    STA BUFBEG+1
040E A2 00    LDX #0
0410 86 15    STX EOFLAG      :CLEAR EOF FLAG
0412 CA      DEX
0413 86 1E    STX BUFEND      :$FFFF IS END DEFAULT
0415 86 1F    STX BUFEND+1
0417 60      RTS

0418          :  KEPX : DISPLAY MESSAGE FROM TABLE

0418 B9 86 04 KEPX  LDA LITS,Y      :GET A CHARACTER
041B F0 06    BEQ KEPOUT      :QUIT ON ZERO
041D 20 7A E9 JSR  OUTPUT
0420 C8      INY
0421 D0 F5    BNE KEPX
0423 60      KEPOUT RTS

0424          :  INDEC : INPUT DECIMAL NUMBER FROM KEYBOARD

0424 20 70 04 INDEC JSR INLIN      :INPUT A LINE
0427 A9 00    LDA #0          :START WITH ZERO
0429 85 18    STA DCOUNT
042B 8D 1E A4 STA CKSUM      :ASSUME NO DEFAULT
042E A2 00    LDX #0          :CLEAR BUFFER INDEX
0430 BD F9 04 DECLUP LDA DECBUF,X  :GET A CHARACTER

0433 C9 0D    CMP #CR      :EOL?
0435 F0 2B    BEQ DECDON     :YES
0437 C9 20    CMP #'/'      :END OF NUMBER?
0439 F0 27    BEQ DECDON     :YES
043B C9 30    CMP #'0'      :VALID DECIMAL DIGIT?
043D 90 1B    BCC BADNUM     :NO
043F C9 3A    CMP ##3A      :NO
0441 B0 17    BCS BADNUM     :NO
0443 29 0F    AND ##0F      :CLEAR HIGH NYBBLE
0445 85 19    STA DECTMP     :SAVE
0447 A5 18    LDA DDCOUNT     :MULTIPLY COUNT BY 10
0449 0A      ASL A
044A 0A      ASL A          :TIMES 8
044B 0A      ASL A
044C 18      CLC
044D 65 18    ADC DDCOUNT     :AND ADD TWICE FOR 10
044F 18      CLC
0450 65 18    ADC DDCOUNT
0452 18      CLC
0453 65 19    ADC DECTMP     :ADD NEW DIGIT
0455 85 18    STA DDCOUNT     :SAVE
0457 E8      INX
0458 D0 D6    BNE DECLUP     :NEXT DIGIT

045A 20 94 E3 BADNUM JSR CKER00    :DISPLAY 'ERROR'
045D 20 F0 E9 JSR  CRLF
0460 38      SEC

0461 60      RTS
0462 8A      DECDON TXA      :ANY ENDTERED?
0463 D0 04    BNE DECDON     :YES
0465 E8      INX
0466 8E 1E A4 STA CKSUM      :NO, SET FLAG
0469 20 F0 E9 DECDUN JSR CRLF     :END LINE
046C A5 18    LDA DDCOUNT     :GET COUNT
046E 18      CLC
046F 60      RTS

0470          :  INLIN : INPUT A LINE OF CHARACTERS FROM KBD
0470          :  AND STORE IN DECIMAL BUFFER

0470 A0 00    INLIN LDY #0      :CLEAR BUFFER INDEX

```

Listing 1 (Continued)

```

0472 20 5F E9 INLUP JSR RDRUB      :READ CHAR WITH DELETE
0475 99 F9 04    STA DECBUF,Y    :SAVE CHARACTER
0478 C9 20    CMP #'/'      :SPACE OR CR ENDS LINE

047A F0 09    BEQ ENDLIN
047C C9 0D    CMP #CR
047E F0 05    BEQ ENDLIN
0480 C8      INY          :BUMP INDEX
0481 C0 15    CPY #LINMAX+1     :MAXIMUM CHARS?
0483 90 ED    BCC INLUP      :NO, GET ANOTHER
0485 60      ENDLIN RTS

0486          :  LITERAL TABLE

0486          LITS  ==

0486 49 4E    LMSG .BYTE 'INPUT LINE LENGTH=',0
0488 50 55
048A 54 20
048C 4C 49
048E 4E 45
0490 20 4C
0492 45 4E
0494 47 54
0496 48 3D
0498 00
0499 53 50    SPMSG .BYTE 'SPACES BETWEEN COLUMNS=',0
049B 41 43
049D 45 53
049F 20 42
04A1 45 54
04A3 57 45
04A5 45 4E
04A7 20 43
04A9 4F 4C
04AB 55 3D
04AD 9B 94 9B
04B0 00
04B1 4E 55    COLMSG .BYTE 'NUMBER OF COLUMNS=',0

04B3 40 42
04B5 45 52
04B7 20 4F
04B9 46 20
04BB 43 4F
04BD 4C 55
04BF 40 4E
04C1 53 3D
04C3 00
04C4 4C 49    LINMSG .BYTE 'LINES PER PAGE=',0
04C6 4E 45
04C8 53 20
04CA 50 45
04CC 52 20
04CE 50 41
04D0 47 45 3D
04D3 00
04D4 4C 49    PERMSG .BYTE 'LINES BETWEEN PAGES=',0
04D6 4E 45
04D8 53 20
04DA 42 45
04DC 54 57
04DE 45 45
04E0 4E 20
04E2 50 41
04E4 47 45
04E6 53 3D
04E8 00
04E9 4D 45    MEMMSG .BYTE 'MEMORY OVERFLOW',0

04EB 4D 4F
04ED 52 59
04EF 20 4F
04F1 56 45
04F3 52 46
04F5 4C 4F 57
04F8 00

04F9          PAGBUF ==
04F9          DECBUF ==

04F9          .END
04F9          ERRORS= 0000

```

## EVER WONDER HOW YOUR APPLE II WORKS?

**QUICKTRACE will show you! And it can show you WHY when it doesn't!**

This relocatable program traces and displays the actual machine operations, while it is running and without interfering with those operations. Look at these **FEATURES**:

**Single-Step mode** displays the last instruction, next instruction, registers, flags, stack contents, and six user-definable memory locations.

**Trace mode** gives a running display of the Single-Step information and can be made to stop upon encountering any of nine user-definable conditions.

**Background mode** permits tracing with no display until it is desired. Debugged routines run at near normal speed until one of the stopping conditions is met, which causes the program to return to Single-Step.

**QUICKTRACE** allows changes to the stack, registers, stopping conditions, addresses to be displayed, and output destinations for all this information. All this can be done in Single-Step mode while running.

**Two optional display formats** can show a sequence of operations at once. Usually, the information is given in four lines at the bottom of the screen.

**QUICKTRACE** is completely transparent to the program being traced. It will not interfere with the stack, program, or I/O.

**QUICKTRACE** is relocatable to any free part of memory. Its output can be sent to any slot or to the screen.

**QUICKTRACE** is completely compatible with programs using Applesoft and Integer BASICs, graphics, and DOS. (Time dependent DOS operations can be bypassed.) It will display the graphics on the screen while **QUICKTRACE** is alive.

**QUICKTRACE** is a beautiful way to show the incredibly complex sequence of operations that a computer goes through in executing a program

**Price: \$50**

**QUICKTRACE** requires 3548 (\$E00) bytes (14 pages) of memory and some knowledge of machine language programming. It will run on any Apple II or Apple II Plus computer and can be loaded from disk or tape. It is supplied on disk with DOS 3.3.

**QUICKTRACE** was written by John Rogers. **QUICKTRACE** is a trademark of Anthro-Digital, Inc.

## QUICKTRACE DEBUGGER

	<b>Last address</b>		<b>Disassembly</b>	
<b>Last instruction</b>	FF69- A9 AA		LDA #AA	
	<b>Top seven bytes of stack</b>		<b>Processor codes</b>	<b>User defined location &amp; Contents</b>
<b>Stack</b>	ST=7C A1 32 D5 43 D4 C1		NV-BDIZC	0000=4C
	<b>Accumulator</b>	<b>X reg.</b>	<b>Y reg.</b>	<b>Stack pointer</b>
<b>Contents</b>	A=AA	X=98	Y=25	SP=F2 PS=10110001
				[ ]=DD
			<b>Disassembly</b>	<b>Reference address</b>
<b>Next instruction</b>	FF6B- 85 33		STA #33	[\$0033]

**Anthro-Digital, Inc.**  
P.O. Box 1385  
Pittsfield, MA 01202  
413-448-8278

Circle No. 52

## UPGRADE YOUR AIM-65\* INSTANTLY

\*A trademark of Rockwell Inc.

**To A 6809 Development System**

With The

**"MACH-9"**

From

**M M S Inc.**

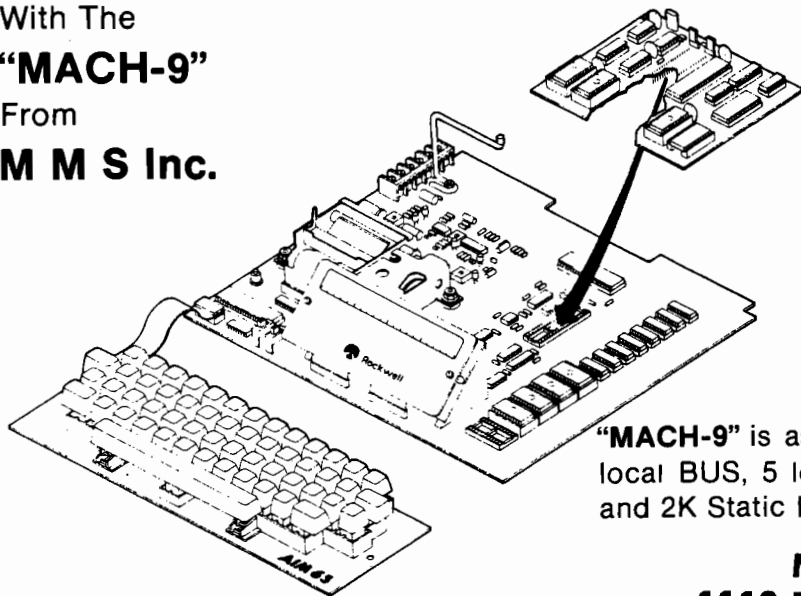

INTRODUCTORY PRICE

**\$239.**

Plus \$6 U.P.S.  
And Handling

Includes:

- \*6809 CPU Plug-in Assembly
- \*Super-set of AIM Monitor
- \*Two-Pass Symbolic Assembler
- \*Complete Monitor Source Listings
- \*Enhanced Cut & Paste Editor
- \*200 Page Manual
- \*Full I/O Control

**"MACH-9"** is assembled and tested with local BUS, 5 locking low force ROM sockets and 2K Static RAM

**M M S Inc.**  
**1110 E. PENNSYLVANIA ST.**  
**TUCSON, AZ 85714**  
**(602) 746-0418**



Circle No. 53

THE NEWEST RELEASE FROM ARTISAN SYSTEMS CORP.

DP-09

2MHZ  
OPERATION

256K DRAM

6 RS-232  
SERIAL PORTS

8 28-PIN  
SOCKETS

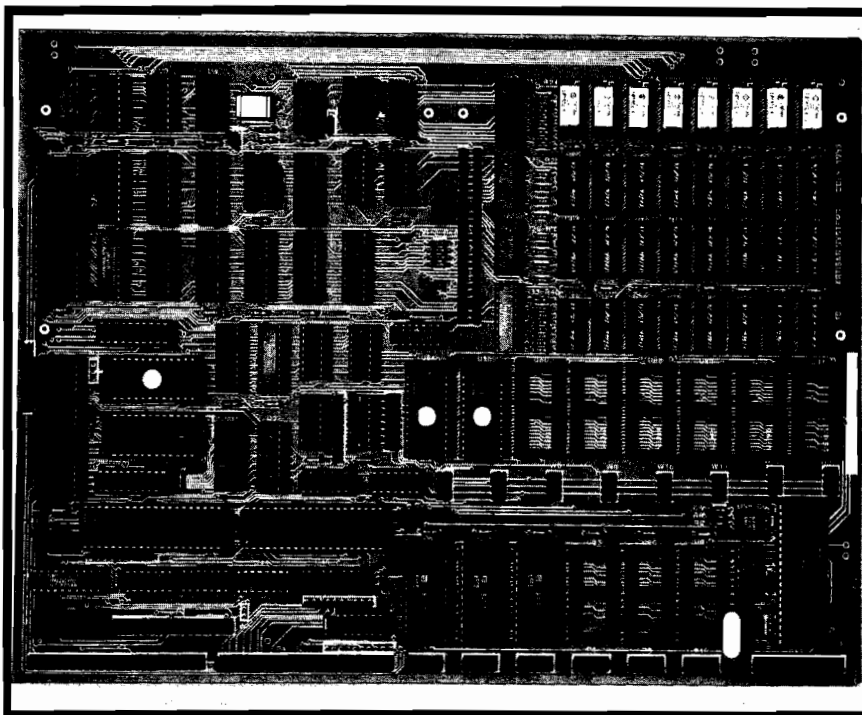

DUAL 68B09E  
PROCESSORS

FLOPPY  
CONTROLLER

WINCHESTER  
INTERFACE

4 LAYER  
PC BOARD

6809 BASED SINGLE BOARD SYSTEM

12"X9"

5V, 4A

±12V, 2A

FEATURES:

- ◆ 68B09E ADVANCED 8/16 BIT SYSTEM PROCESSOR WITH MEMORY MANAGEMENT HARDWARE ALLOWS FOR ONE MEGABYTE ADDRESS SPACE
- ◆ 64K - 256KBYTE DRAM
- ◆ 8 EACH 28-PIN SOCKETS FOR UP TO 128KBYTE EPROM EPROMS CAN BE 2732, 2764 OR 27128 IN ADDITION 2KX8 OR 8KX8 STATIC RAMS MAY BE USED
- ◆ SIX RS-232 SERIAL PORTS WITH FULL MODEM HANDSHAKE ADVANCED 6551A ACIAs WITH SOFTWARE BAUD RATE SELECT OF 110 TO 19.2KBAUD
- ◆ 6522A INTERFACE CHIP PROVIDES TWO 16-BIT TIMERS PLUS TWO 8-BIT PARALLEL PORTS (UNBUFFERED)
- ◆ 8 AUTO-VECTORED INTERRUPTS FOR HIGH SPEED I/O HANDLING
- ◆ 50-PIN EXPANSION SOCKET

- ◆ INDEPENDENT 68B09E SUBSYSTEM FOR DISK CONTROL 1-4 FLOPPYS 5" OR 8" SS DS SD DD SASI INTERFACE ALLOWS 5-45MBYTE WINCHESTERS TO BE CONNECTED USING EXTERNAL CONTROLLER THE SUBSYSTEM USES A PROPRIETARY DMA TECHNIQUE FOR HIGH SPEED OPERATION
- ◆ FLEX OPERATING SYSTEM IS AVAILABLE

PRICES:

DP-09 A&T 64K 4 SERIAL PORTS	\$795(1-9)
FLEX FOR DP-09	\$150
OS-09 LEVEL ONE & TWO	CALL
FORTH	CALL

TERMS:

- ALL ORDERS PREPAID, VISA, OR MASTERCARD
- ALLOW 3 TO 4 WEEKS FOR DELIVERY
- ADD 2 WEEKS FOR PERSONAL CHECKS

ARTISAN SYSTEMS CORP.  
410 CROSS ST.  
WINCHESTER, MA 01890  
(617) 721-2109

Circle No. 54

# Superboard II / Quick Printer II

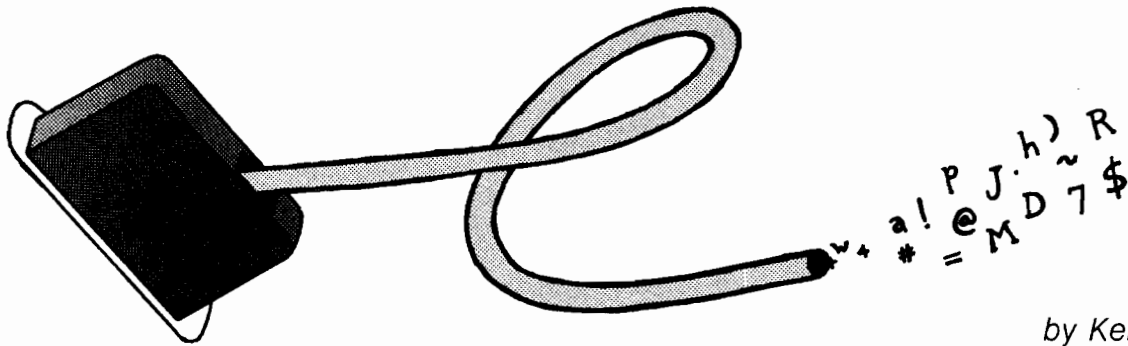

by Ken Benson

## SB II/QP II

requires:

OSI Superboard II  
Radio Shack Quick Printer II

This article describes an inexpensive way to interface an OSI Superboard II to a Radio Shack Quick Printer II.

After looking at a number of printers, I decided on the Radio Shack Quick Printer II, principally because of the reasonable price, but also because it was a complete package. A study of the schematic indicated that it should be possible to use the TRS-80 bus connector as a way into the Quick Printer II. A cable was included with the printer that could be used for this purpose, thus saving a few dollars.

Connected to the printer bus are 8 data lines, 16 address lines, an RD, and a WR line. The address lines decode to \$37E8, which is the memory address for printer I/O in the TRS-80 Model I.

The Superboard II has a 40-pin expansion connector, which I have traced out; it seems that OSI forgot to put it on the schematic. The expansion connector includes 8 data lines, 16 address lines, and an R/W\* line (the \* denotes active low). I wondered if this would be enough to interface to the printer? If so, what means of addressing could be utilized? Would it be necessary to write all new software for the printer?

I thought it would be easy if I could use my Superboard II cassette routine that outputs to \$F001, so I studied the address decoder in the Quick Printer II to see how difficult it would be to change the address. It looked like just switching a few leads would do it; in fact, I decided to try switching leads in the interconnect cable.

I removed one TRS-80 bus connector from the interconnect cable that had come with the Quick Printer II,

table 1

QP II Pin /	QP II Function	Goes To	SB II Function	SB II Pin /
4	A10	<=>	A15	27
5	A12	<=>	A14	26
6	A13	<=>	A13	25
7	A15*	<=>	GND	38
8	GND	<=>	GND	37
9	A11*	<=>	GND	10
10	A14*	<=>	GND	9
11	A8	<=>	A12	24
13	WR*	<=>	R/W*	32
17	A9	<=>	A0	14
18	D4	<=>	D4	36
20	D7	<=>	D7	34
22	D1	<=>	D1	5
24	D6	<=>	D6	34
25	A0*	<=>	A11*	23
26	D3	<=>	D3	7
27	A1*	<=>	A10*	22
28	D5	<=>	D5	35
29	GND	<=>	GND	29
30	D0	<=>	D0	4
31	A4*	<=>	A9*	21
32	D2	<=>	D2	6
37	GND	<=>	GND	28
40	A2*	<=>	A8*	20

Check the connections carefully because the interconnect cable may not be numbered correctly. Note that pin number 1 on the QP II is on the lower left when facing the rear of the printer. Also U6 and U7 (8128's) must be populated.



and then attached a 40-pin DIP plug on the end, as shown in table 1. The RD line is not utilized, since it is not used in the TRS-80 alternate connection with the Expansion Interface. I thought operation would still be possible with this line deleted, and this proved to be the case. Crossing the lines fools the printer address-decoder logic into thinking it is addressed at \$37E8 by the cassette output routine of Superboard II to \$F001.

Unfortunately, a few minor problems occur. Because there is no handshake, the computer has to wait for the printer, or data will be lost. This means you must list or print in the "SAVE" mode, and you must set the terminal width to 31 using the command POKE 15,31. The "SAVE" mode then forces a carriage return and 10 nulls just as the printer is about to CR/LF automatically. This enables the printer to keep pace with the computer. Don't forget to reset line length to 72 before a cassette save or you will lose information upon reloading (the reloading program will have data after a carriage return and no line number for it).

Another problem is that you get a "?" for the first character of each line. I am not sure why this happens, but it

could be because the "PRINT" token in SB II is "?". This is no problem for me, since I am interested only in program or disassembler listings. However, it does become difficult to print plain text or to use the large-character feature of the QP II (large characters are 15 per line, small are 32 per line), but it can be done. The trick is to write strings and POKE to the output. You can obtain the large letters in this manner. The specific procedure is as follows:

```
POKE 61441,13 (CR)
FOR W = 0 TO 500 : NEXT (wait for
    printer to get ready)
POKE 61441,15 (shift to large format)
```

The desired message could then be printed in the following manner:

```
A$ = "TEXT TO BE PRINTED"
L = LEN(A$)
FOR N = 1 TO L
    POKE MID$(A$,N,1)
NEXT N
```

I get two other bugs that may not bother other systems. I am using a modulator and a TV, so I get some in-

terference on the screen. The other is that noise from the printer sometimes stops my program when I'm printing. Placement of the unit and cable affect this and I suspect it could be a grounding problem.

In summary, I am pleased with this configuration. It works well for program lists and for my disassembler. The silver paper is somewhat difficult to read because of the glare, but it copies nicely. Admittedly, this arrangement is not the most elegant. For someone on a tight budget, however, it might prove to be the perfect solution. Since hooking up this system I've seen a modification to double the baud rate of SB II from 300 to 600. With that modification installed the serial port might be used, although POKE might not work then. I've written a short routine that lets me print out what is being input to SB II, so I don't plan to make that change now; I may try it eventually for the faster loading.

---

K.L. Benson works for Hughes Aircraft Company as a microwave standards engineer. He may be contacted at 745 Venice Way, Apt. 1A, Inglewood, CA 90302.

---

**MICRO™**

## **PERRY PERIPHERALS REPAIRS KIMs!!** **(SYM and AIMs Too)**

- We will Diagnose, Repair, and Completely Test your Single Board Computer
- We Socket all replaced Integrated Circuits
- You receive a 30-day Parts and Labor Warranty
- Your repaired S.B.C. returned via U.P.S. — C.O.D., Cash

Don't delay! Send us your S.B.C. for repair today  
Ship To: (Preferably via U.P.S.)

**PERRY PERIPHERALS**  
6 Brookhaven Drive  
Rocky Point, NY 11778

### **KIM-1 Replacement Modules**

- Exact replacement for MOS/Commodore KIM-1 S.B.C.
- Original KIM-1 firmware — 1K and 4K RAM versions

### **REPLACEMENT KIM-1 Keyboards**

- Identical to those on early KIMs — SST switch in top right corner
- Easily installed in later model KIMs

*Perry Peripherals is an authorized HDE factory service center.*

*Perry Peripherals carries a full line of the acclaimed HDE expansion components for you KIM, SYM, and AIM, including RAM boards, Disk Systems, and Software like HDE Disk BASIC V1.1. Yes, we also have diskettes. For more information write to: P.O. Box 924, Miller Place, NY 11764, or Phone (516) 744-6462.*

Circle No. 55

# FOCUS ON THE 6809 MICRO WORTH SWITCHING FOR

## FOCUS ... ON ITS SUPERIOR HARDWARE

- 6809E Microprocessor provides 8-bit economy with 16-bit capabilities, position independent code and many advanced features
- Commercial quality Keyboard with full UPPER/lower case ASCII, numeric keypad and cursor control keys
- Two double-sided double-density mini diskettes with 640K bytes of IBM-compatible storage
- 56K Bytes User RAM
- Full Video with programmable screen formats, bit mapped graphics, user definable character sets, reverse video and hardware scrolling, plus a light pen interface
- Full Communications support for RS-232 at 50 to 19.2K baud with programmable data formats
- Built-in I/O Drivers include 6 parallel I/O ports, 3 serial I/O ports, 6 timers/counters, 20 mA current loop, and a programmable cassette interface

## FOCUS ... ON ITS EXTRAORDINARY SOFTWARE

- Includes the popular FLEX™ Operating System — a standard for the 6809 (supported by many vendors.)
- Extended Floating Point Disk BASIC Interpreted and Compiled
- Text Editor and Macro Assembler
- Full feature FlexIMon debugging monitor
- Built-in Word Processor

## FOCUS ... ON ITS VERSATILE EXPANDABILITY

- IEEE-488 Bus Controller option for instrumentation
- Supports multiple 8" diskette drives
- PASCAL, FORTH and other high level programming languages are available
- Complete Application Packages are available from many software sources
- Add-on Hardware includes: Date/Time, Opto-Isolators, Stepper-Motor Controller, A/D and D/A, RAM and EPROM Memory, and others from several manufacturers

## FOCUS ... ON YOUR APPLICATION REQUIREMENTS

- FOCUS provides a completely integrated system of hardware and software, so that you can concentrate on your application requirements

**MICRO SPECIAL!**  
**\$3495<sup>00</sup>**

**IF ORDERED BY MAY 31, 1983**  
Include copy of this ad  
with order and receive  
**TypePlus™ Word Processor**  
**FREE!**



**\$3995<sup>00</sup>**

**VERY COMPLETE**

**THE COMPUTERIST®**

34 Chelmsford Street  
Chelmsford, MA 01824  
Phone: 617/256-3649  
Telex: 955318 INTL DIV

## Interface Clinic

by Ralph Tenny

The first two sessions in this series began laying the groundwork for interfacing experiments. At this point some readers need more information but others may be bored. So, to keep everyone interested, I will begin some simple experiments. A text on assembly language was recommended in last month's column, and I recommend the sources listed below as additional study material.

*MICRO Cookbook*, Don Lancaster, Howard W. Sams & Co., Inc. #21828  
*CMOS COOKBOOK*, Don Lancaster, Howard W. Sams & Co., Inc. #21398  
*NCR Basic Electronics Course*, Howard W. Sams & Co., Inc. #21549  
*Guide to CMOS Basics, Circuits & Experiments*, Howard M. Berlin, Howard W. Sams & Co., Inc. #21654

Note that the references cited cover background material and do not deal with a specific computer. The NCR Basic Electronics Course is entry-level material and offers a broader range of

useful topics than the other books. I recommend that CoCo owners obtain the Service Manual for the Color Computer (Radio Shack catalog #26-3001/3002), and that owners of other computers obtain similar hardware manuals for their own computer. I will mention various precautions regarding CoCo interfacing; these will be valid for other computers according to their particular design architecture.

As I move into the area of hardware experiments, you will need certain tools and materials to duplicate and expand upon the ideas presented. The only construction tools that you will need are those included in small kit-building sets available from Radio Shack and Heathkit. Accessories such as interface cables and similar hardware will be specified as the need arises. In general, experiments and interfaces will be designed around parts available from Radio Shack. Those who know how are encouraged to substitute whatever source is convenient; to this end both generic part numbers and Radio Shack catalog numbers will be used to specify parts used in the

designs. If possible, each experimenter should obtain a small 5-volt supply to power these experiments; Radio Shack #277-125, a low-cost kit, will suffice. Often, a 6-volt lantern battery can be used for the experiments, including this month's circuits.

The Color Computer has only a few lines devoted to input and output (I/O). While you will eventually learn how to expand CoCo's I/O capability, first learn to use the existing capability. Our first experiment will use the serial port (printer port) for single-line output and input as a familiarization exercise. Figure 1 shows the output and input circuits used in the serial port. These circuits bridge the gap between the PIA used for I/O in the Color Computer and the outside world. That is, the PIA signal levels must be changed from digital logic signals to RS-232 signal levels.

RS-232-level signals are used to interconnect almost all types of computer peripherals to the computers. RS-232 signals are defined by the voltage levels shown in figure 2; note that *valid* signals will be greater than +3 volts for a logic zero or less than -3 volts for logic one. The deadband between +3 volts and -3 volts is used for noise immunity on long signal paths that may have external interference.

Digital logic signals are typically defined as being less than 0.8 volts for logic 0 and greater than 2.2 volts (typically 3.5 volts) for logic 1 signals.

**Figure 1. Serial I/O on the Color Computer is done with two amplifiers that change digital logic signal levels from the PIA to RS-232 levels. See text for more details.**

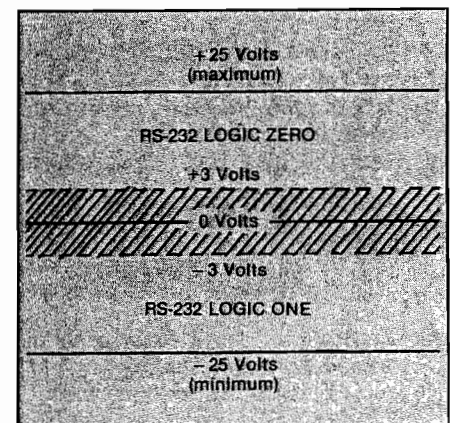
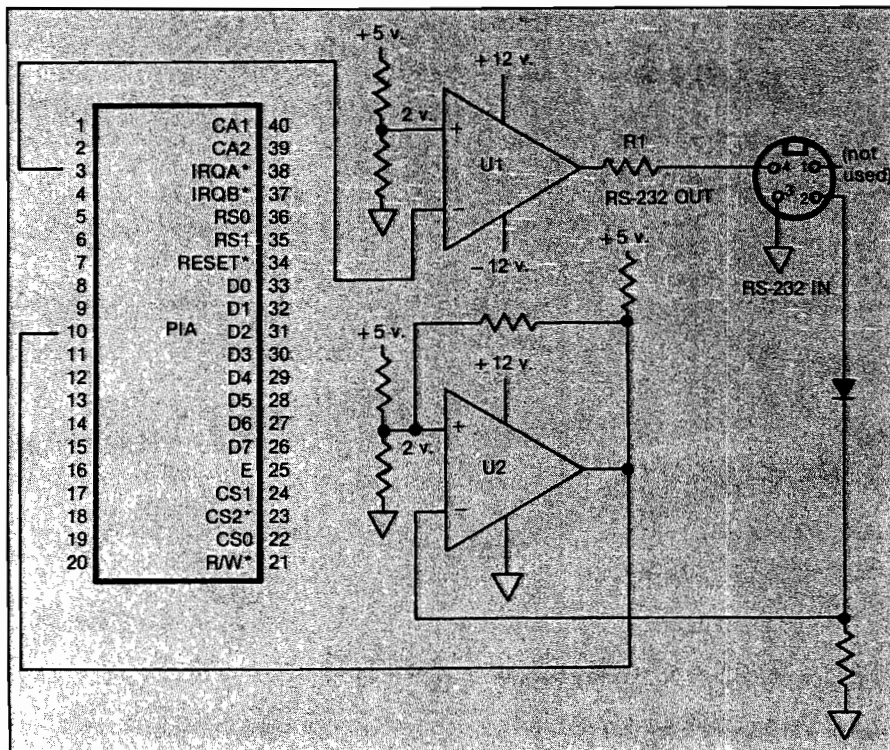

**Figure 2. Diagram showing voltage levels of RS-232 signal channels. Signal deadband between +3 volts and -3 volts gives noise immunity for long cable runs in noisy environments.**

U1 and U2 are special ICs that do the voltage translation from unipolar logic levels to bipolar RS-232 signals. U1's output can swing almost 12 volts plus and minus, with R1 limiting current to the external load. U2's output line is powered from the +5-volt bus, so it cannot swing higher than 5 volts; this avoids overdriving the PIA input line. Note that both U1 and U2 have dual inputs; one input is held at +2 volts by a resistor network. When the other input

Figure 4 shows a LED (light emitting diode) driven by a single transistor; the circuit design allows us to safely drive the transistor with almost 24 volts of signal (+ and - 12 volts) from CoCo's serial output line. When the transistor is turned on, current will flow through the LED and transistor, lighting the LED. When the serial output line goes high (RS-232 logic 0), the transistor turns on. Diode D1 comes in to play when the signal swings negative

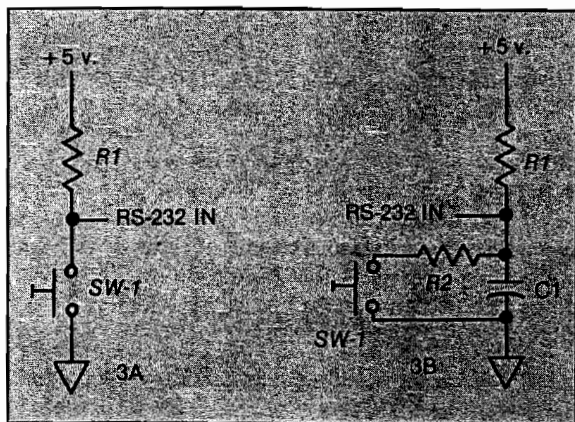

**Figure 3. Switch inputs for the RS-232 IN line. In 3A, a naked switch can generate multiple input level transitions as the mechanical contacts bounce during operation. Additional components in 3B prevent switch bounce from generating more than one closure signal.**

is lower than 2 volts, the output will swing high; any input above 2 volts causes the output to switch low.

Figure 3A is an example of using a switch to generate an input signal for U2. This simple design has a major flaw that ignores an innate characteristic of any mechanical switch. When the contacts of a mechanical switch come together they invariably bounce, making and breaking the contact several times. Computers and other electronic circuits are fast enough to react to each bounce, giving the effect of several switch closures. Consequently, the additional components shown in figure 3B are used to prevent the multiple closures from generating multiple signals. Resistor R1 requires a long time to charge capacitor C1; when the switch discharges C1 and then bounces open, the voltage input to U2 cannot change fast enough to cause U2 to switch. Even if the switch bounces a number of times before staying closed, only one signal is generated. When the switch opens, any bounce will have died away before U2's input can change, and again only one signal is generated. R2 limits the discharge current to protect the contacts.

(RS-232 logic 1). D1 is forward biased (current flows in the direction of the arrow symbol), which allows it to absorb the current generated by the input signal. This is a necessary precaution for many transistors, since their input may not be able to withstand the -12 volts reverse voltage that would otherwise be applied to the transistor.

To use the interface we have designed, it will be necessary to program the internal PIA so that it will respond to our signal (switch closure) and to turn on the transistor LED driver. During system reset, all PIA internal registers are set to zero, which programs all PIA I/O lines as inputs. As CoCo boots up into operation, the PIA registers are initialized so that each I/O line is set up for its assigned task. For this experiment, we will use the same initialization and we can skip a step normally required to use a PIA. To turn on the transistor, we must set the RS-232 line high (RS-232 logic 0). This is done by setting the PIA output line to digital logic 0. Similarly, to detect a switch closure, we must read the RS-232 input line on the PIA. Our circuit design causes a logic 1 to appear on the port pin when the switch is closed.

Since the PIA is controlled by the processor data bus, each I/O transaction involves eight bits; we will have to sort out the single input or output bit associated with our circuit. In figure 1 note that PA1 drives the output amplifier, while PB0 is driven by the input amplifier. Port 1 (PA0-PA7) is located at \$FF20, and Port 2 (PB0-PB7) is located at \$FF22.

To separate those two port lines, we must use the Boolean operators AND and OR if we program in BASIC. For example, the following program will alternately turn on and turn off line PA1 of the PIA;

```
10 A = PEEK(65312):C = A AND 254:
   POKE(65312),C
20 B = PEEK(65312):C = B OR 2:POKE
   (65312),C
30 GOTO10
```

For those unfamiliar with these instructions, the BASIC AND instruction performs the Boolean AND operation using these Boolean statements: 1 AND 1 = 1, 1 AND 0 = 0, as illustrated here.

	10101100
AND "Mask"	11110000
Result	10100000

This simple problem shows the characteristics of logical AND operations. First, the operand for the AND is

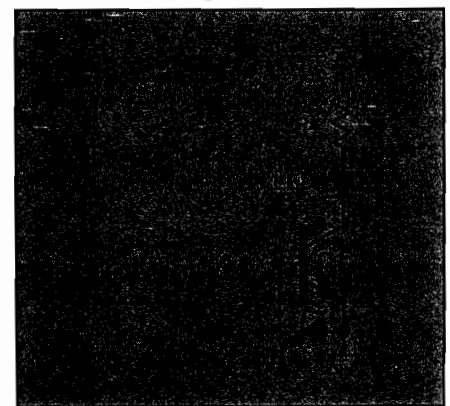

**Figure 4. LED driver circuit to receive RS-232 level signals from the RS-232 OUT line. Diode D1 protects transistor base from excessive reverse voltage when RS-232 signal swings to -12 volts for logic one signal.**

called a mask; in hex notation, the mask used above is \$F0. The name mask comes from the fact that the all-ones nibble (half a byte) protected the corresponding four bits, while the all-zeros nibble blanked out the four bits in the low-order nibble. We say that 0 bits turn *off* corresponding bits in the value being operated on. Similarly, the OR instruction turns *on* corresponding bits in a binary word:

```

OR "Mask"  10101100
           11110000
-----
Result     11111100

```

Re-read the BASIC program example and note that line 10 reads the value in location 65312, turns *off* PA1 without changing *any other bit*, then rewrites the value. Line 20 reads the value, turns *on* PA1, and restores the word to the port. It is often important to change only one bit of an I/O port at a time, and this program is one way to do it.

An assembly-language program that does the same thing follows:

```

START LDA  $FF20 READ THE
           LOCATION
        ANDA #$FD  TURN OFF BIT 1

```

```

STA  $FF20 REPLACE VALUE
LDA  $FF20 READ VALUE
      AGAIN
ORA  #$02  TURN ON BIT 1
STA  $FF20 REPLACE VALUE
BRA  START LOOP FOREVER

```

On the input side, the following BASIC program will test PBO of the port (RS-232 IN line):

```

10 A = PEEK(65314):B = A AND 254:
   IF B = 0 THEN 30

```

With these programming examples, our interface design in figures 3 and 4 can come alive. The circuits can be built using any construction techniques you wish; the layout is not critical. A list of suggested parts is included below. Although this is a rudimentary design, it is one type of interface applicable to many home computers that are capable of driving standard printers. Future examples will expand this single-bit port to multi-bit operation, and suggest some support circuitry.

The circuit shown is quite safe for the computer as long as it is wired as shown. Special precautions: do not expose any pin of the serial port to

voltages higher than 6 or 7 volts; do not expose pin 4 to a voltage input at all. Similar statements can be made about any other computer, with suitable modification regarding pin numbers of the port connector.

#### Parts List for Single-Bit Serial I/O

- R1 - 4.7K (4700) ohm ¼ w. resistor, R/S p/n 271-1330
- R2 - 10 ohm ¼ w. resistor, R/S p/n 271-1301
- R3 - 10K (10000) ohm ¼ w. resistor R/S p/n 271-1335
- R4 - 22 ohm ¼ w. resistor [use 2 R/S #217-1307 in parallel]
- C1 - 22 µF 16-volt capacitor, R/S p/n 272-1426
- SW-1 push button switch, R/S p/n 275-1547 or 276-618, 276-1549
- LED [any color] R/S p/n series 276-041 - 276-071
- D1 - 1N914 or 1N4148, R/S p/n 276-1122
- Cable serial port - R/S p/n 26-3020 (makes two; cut in half)
- Breadboard - R/S p/n 276-170 or 276-158

Please forward questions and suggestions for discussion topics to Mr. Tenny at P.O. Box 545, Richardson, TX 75080.

**MICRO™**

## TELECOMMUNICATIONS on the VIC and '64!

"A versatile and exceedingly well-done package." David Malmberg, MICRO  
 "Simply the best & nicest VIC terminal software I have seen."  
 Greg Yob, CREATIVE COMPUTING

We created quite a flurry and earned rave reviews with *Terminal-40*, the unique software that transforms the VIC screen into a 40-column smooth-scrolling display. And with features like a Receive Buffer and VIC printer dump, *Terminal-40* sets a new standard for personal modem communications with networks such as CompuServe and Source. Our '64 *Terminal* does the same quality job for the '64.

And now there's even MORE!!! *SuperTerm* for the VIC and '64 supports text storage to disk or tape and program UPLOAD/DOWNLOAD. *SuperTerm*, used with our Smart ASCII interface, also supports popular parallel printers.

Choose the one right for you. Call or write today for the "best", then...

For the VIC:  
*Terminal-40* (req. 8K exp) \$29.95  
*SuperTerm* (req. 16K exp) Call

For the Commodore 64:  
 '64 *Terminal* \$29.95  
*SuperTerm* Call

(On cassette. Requires modem.)



311 W. 72nd ST. • KANSAS CITY • MO • 64114

# REACH OUT and BYTE SOMEONE!

ORDER DESK: (816) 333-7200

Send for a free brochure describing our other quality products.

MAIL ORDER: Add \$1.50 shipping and handling (\$3.50 for C.O.D.). VISA/Mastercard add 3% (card# and exp. date). Missouri residents include 4.8% sales tax. Foreign orders payable U.S. U.S. Bank ONLY, add \$5 shipping. Dealer inquiries invited.



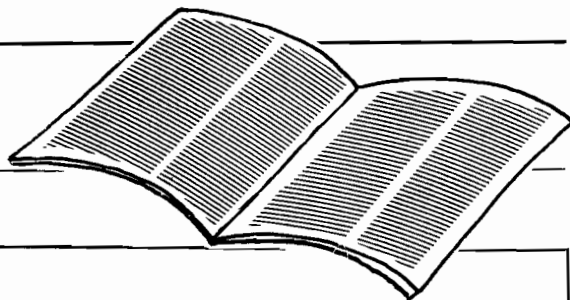

## Annual Index

### APPLICATIONS

AIM User Function Dispatcher <i>Joel Swank</i>	49:13
Add A VIA and speech Synthesizer to the Color Computer <i>William C. Clements Jr.</i>	49:19
A Sequential File Handler for a Disk-Based OSI <i>Mark Johnson and Chris Johnson</i>	49:26
Face Synthesizer for PET <i>David Heise</i>	49:31
AIM Logic Trainer <i>Larry Kollar</i>	49:45
A Versatile Disc Label Printer <i>David Allen</i>	49:50
Program for Inverting a Matrix <i>Brian J. Flynn</i>	49:54
Tiny PILOT for the PET <i>Jim Strasma and John O'Hare</i>	49:73
Print AT for OSI Systems <i>Matt Asay</i>	49:87
Rewriting PET ROMs <i>James Yost</i>	50:9
Timing and Counting with the 6522 <i>Marvin L. DeJong</i>	50:13
Apple Disk Sector Map Utility <i>Clyde Camp</i>	50:45
TAPDUP-AIM Tape Copy Utility <i>Joel Swank</i>	50:98
Interfacing the Color Computer <i>John Steiner</i>	51:33
Expanding File Cabinet for the Apple <i>Charles F. Taylor</i>	51:49
Duty Cycle Monitor for the VIC-20 <i>Bob Kovacs</i>	51:27
A/D Conversion Using a 555 Timer IC <i>Mike Dougherty</i>	52:14
Market Projection Program for the Color Computer <i>Leonard I. Suckle</i>	52:67
Double-Entry Formatting for Your Checkbook on the C1P <i>Leo Jankowski</i>	52:80
Auto SAVE for the PET <i>Louis D. Sander</i>	52:83
Machine-Language Screen Utilities for the CBM-8032 <i>Thomas Henry</i>	53:11
Auto Graph for the Apple <i>Eugene J. Rolfe</i>	53:15
The IBM Selectric as an OSI System Printer <i>Paul Krieger</i>	53:27
Formatted Output with Atari BASIC <i>Frank Roberts</i>	53:75
Squeeze for PET BASIC Program <i>Hans Hoogstraat</i>	55:42
BASIC Line Delete for PET/CBM and VIC <i>Thomas Henry</i>	55:47
Soup: A CBM Machine-Language Compare Program <i>Henry Troup and Jim Strasma</i>	55:52
Adding Voice to a Computer <i>Michael E. Valdez</i>	55:69
Discrete Event Simulation in Pascal <i>Anita and Bill Walker</i>	56:21
Doing Time on the 6809 <i>Jim Schreier</i>	56:28
Model Rocket Simulation in BASIC <i>David Eagle</i>	56:31

Sun and Moon on the Apple <i>Svend Ostrup</i>	56:35
Microcomputers in a College Teaching Laboratory, Part 3 <i>Thor Olsen, Howard Saltsburg, Richard H. Heist</i>	56:38
Measurement of a 35mm Focal Plane Shutter <i>Mike Dougherty</i>	56:45
Signed Binary Multiplications Unsigned <i>Timothy Stryker</i>	56:76
Apple Math Editor <i>Robert D. Walker</i>	56:78
A Binary Search Routine <i>Alfred J. Bruey</i>	57:37
EDIT: An Atari FORTH Screen-Oriented Editor <i>Mike Dougherty</i>	57:47
A BASIC MatchRoutine for CAI <i>Robert Phillips</i>	57:81
Print Control for Apple Printers <i>John R. Vokey and H. Cem Kaner</i>	58:24
Centronics Printer Driver for Your Microcomputer <i>Larry R. Hollibaugh</i>	58:31
MICRO Calc for Commodore and Apple <i>Loren Wright</i>	58:47
Digi-Draft for Atari 400/800 <i>Tim Kilby</i>	58:57
Dialing the Networks <i>Cliff Glennon</i>	59:38
Multi-Microprocessor Tidbits <i>Mike Rosing</i>	59:50
Conservation of Momentum for Atari and Commodore <i>Jerry Faughn</i>	59:84
Is a Number a Number? <i>Phil Daley</i>	59:86
Analysis of Bond Quotations on the Apple <i>David C. Lewis</i>	59:92
Mutual Fund Charting for Apple and OSI <i>Ralph H. Green</i>	59:98
LETTERMASK: A Check-Protecting Algorithm <i>Barton M. Bauers, Jr.</i>	59:102

### BUSINESS

Analysis of Bond Quotations <i>David C. Lewis</i>	59:92
Mutual Fund Charting for Apple and OSI <i>Ralph H. Green</i>	59:98
LETTERMASK: A Check-Protecting Algorithm <i>Barton M. Bauers, Jr.</i>	59:102

### COMMUNICATIONS

Disk to Tape Backup Utility <i>Richard Merten</i>	49:9
Horizontally Scrolled Messages <i>Chris Williams</i>	49:83
PET Communicates with Apple <i>Frank Covitz</i>	50:40
Data Transfer from AIM to PET <i>Alan K. Christensen</i>	51:11
PET to AIM Download <i>George Watson</i>	51:17
Communications: The Growing Network <i>Bradley L. Coley, Jr.</i>	59:26

## Annual Index *(continued)*

A Not-So-Dumb Terminal Program for the SuperPET <i>Terry M. Peterson</i>	59:31	FORTH for the 6809 <i>Ronald W. Anderson</i>	57:62
Dialing the Networks <i>Cliff Glennon</i>	59:38	The World According to LISP <i>Steven Cherry</i>	57:65
A Home-Built Communications Interface <i>John Steiner</i>	59:44	68000 Program Control Branch and Jump Instructions <i>Joe Hootman</i>	57:74
PET-to-PET Communications <i>F. Arthur Cochrane</i>	59:47	More on Tiny PILOT for the PET <i>Arthur Hunkins</i>	57:78
Multi-Microprocessor Tidbits <i>Mike Rosing</i>	59:50	A BASIC Match Routine for CAI <i>Robert Phillips</i>	57:81
In-House Communication <i>Phil Daley</i>	59:54	An Overview of Educational Software <i>George Ggerhold</i>	57:86
Apple, Mountain, and Data Capture <i>H. Bruce Land, III</i>	59:58	Microcomputers in a College Teaching Laboratory-Part 4 <i>Richard Heist, Thor Olsen, and Howard Saltsburg</i>	57:89
<b>EDUCATION</b>			
BASIC, FORTH, and RPL <i>Timothy Stryker</i>	49:63	MICRO Calc for Commodore and Apple <i>Loren Wright</i>	58:47
Tiny PILOT for the PET <i>Jim Strasma and John O'Hare</i>	49:73	68000 BCD and Privileged Instructions <i>Joe Hootman</i>	58:73
Microcomputer Interfacing: FORTH vs. BASIC <i>Mark Bernstein</i>	49:77	Multi-Microprocessor Tidbits <i>Mike Rosing</i>	59:50
Timing and Counting with the 6522 <i>Marvin L. DeJong</i>	50:13	In-House Communication <i>Phil Daley</i>	59:54
An Overview of Apple DOS <i>David P. Tuttle and Dr. Thomas Cleaver</i>	50:25	The Computer Revolution Reaches the Community <i>Emmalyn H. Bentley</i>	59:61
Computer-Assisted Translation of Programs from 6502 - 6809 <i>Edgar Pass</i>	50:77	Master for VIC and Commodore 64 <i>Loren Wright</i>	59:70
The 68000 and the Personal Computer <i>Laurence Kepple</i>	52:27	Is a Number a Number? <i>Phil Daley</i>	59:86
An MC68000 Overview <i>Tom Whiteside and Joe Jelemensky</i>	52:32	<b>GAMES</b>	
68000 Instruction Set <i>Joe Hootman</i>	52:41	Castle Adventure for PET and Apple <i>David Malmberg</i>	54:41
6809 Macros for Structured Programming <i>Hal Clark</i>	52:57	SYM 23 Matches <i>Matt Ganis</i>	54:49
Three Faces of Apple LOGO <i>Edward H. Carlson</i>	53:41	Solve the Pagoda Puzzle Using Recursive Assembly <i>Sherwood Hoyt</i>	54:53
One Teacher's PET <i>Gloria Stein</i>	53:49	VIC/PET GOMOKU <i>David Malmberg</i>	54:59
Microcomputers in a College Teaching Laboratory-Part 1 <i>Richard Heist, Thor Olsen, and Howard Saltsburg</i>	53:53	Number Shuffle on the Atari <i>Frank Roberts</i>	54:62
A Personal Computer for Untrained Users <i>Lynda B. M. Ellis and John R. Raines</i>	53:59	Space Invasion for OSI C1P/Superboard <i>John Seybold</i>	54:70
Apple Pascal P-Code Interpreter and the 6809 <i>Tom Whiteside</i>	53:79	Apple Shootdown <i>Eric Grammar</i>	54:72
An MC68000 Overview, Part 2 <i>Joe Jelemensky and Tom Whiteside</i>	54:13	MASTER for VIC and Commodore 64 <i>Loren Wright</i>	59:70
68000 Binary Arithmetic Operations <i>Joe Hootman</i>	54:27	<b>GRAPHICS</b>	
68000 Logic Instructions <i>Joe Hootman</i>	55:85	Additional Output Ports for KIM <i>Joel Swank</i>	49:17
Microcomputers in a College Teaching Laboratory-Part 2 <i>Richard Heist, Thor Olsen, and Howard Saltsburg</i>	55:59	A Low-Cost Digitizer for the Apple <i>Jay Sinnett</i>	49:40
68000 Shift, Rotate, and Bit Manipulation <i>Joe Hootman</i>	56:15	AIM Logic Trainer <i>Larry Kollar</i>	49:45
Microcomputers in a College Teaching Laboratory-Part 3 <i>Richard Heist, Thor Olsen, and Howard Saltsburg</i>	56:38	Horizontally Scrolled Messages <i>Chris Williams</i>	49:83
Microcomputer Design of Transistor Amplifiers <i>Andy Cornwall</i>	56:59	Removing Frustrating Interference <i>Patrick E. Hamel</i>	50:23
VIC RS-232 Printer <i>Michael V. Tulloch</i>	57:17	Converting Apple Pictures to a Standard Bit-Mapped Format <i>David Lubar</i>	50:35
SuperPET APL <i>Terry Peterson</i>	57:43	Low-Resolution Graphics for Apple Pascal <i>Richard C. Vile Jr.</i>	50:63
An Introduction to FORTH <i>Ronald W. Anderson</i>	57:58	Data Transfer from AIM to PET <i>Alan K. Christensen</i>	51:11
		Atari Character Graphics from BASIC, Part 1 <i>Paul S. Swanson</i>	53:87

## Annual Index *(continued)*

Atari Character Graphics from BASIC, Part 2 <i>Paul S. Swanson</i>	54:82	Duty Cycle Monitor for the VIC-20 <i>Bob Kovacs</i>	51:27
Extra Colors for the Atari <i>Richard I. and Donna M. Marmon</i>	54:96	Interfacing the Color Computer <i>John Steiner</i>	51:33
Atari Character Graphics from BASIC, Part 3 <i>Paul S. Swanson</i>	55:22	Superimposing TV Pictures on PET Video <i>Peter D. Hiscocks</i>	52:11
Enhanced Video for OSI C1P <i>David Cantrell and Terry Terrance</i>	55:74	A/D Conversion Using a 555 Timer <i>Mike Dougherty</i>	52:14
Home Control Interface for C1P <i>John Krout</i>	55:74	Delayed Reset and Autoboot for the OSI <i>Ugo V. Re</i>	52:23
Utilizing the 6502 Undefined Operation Code <i>Curt Nelson, Rod Neisler, Richard Villarreal</i>	55:93	Building a Parallel Printer Interface <i>Rolf B. Johannesen</i>	53:23
VIC Hi-Res Graphics Explained <i>Nicholas J. Vrtis</i>	56:11	The IBM Selectric as an OSI System Printer <i>Paul Krieger</i>	53:27
Sun and Moon on the Apple <i>Svend Ostrup</i>	56:35	A Homespun 32K Color Computer <i>Ralph Tenny</i>	53:91
Apple Math Editor <i>Robert D. Walker</i>	56:78	Installing Atari Joysticks on the OSI <i>Joseph Ennis</i>	54:9
Apple Pascal Hi-Res Screen Dump <i>Robert D. Walker</i>	57:54	A Monitor for the Color Computer <i>Ralph Tenny</i>	54:19
Microcomputers in a College Teaching Laboratory, Part 4 <i>Deborah Graves, Richard H. Heist, Thor Olsen, Howard Saltsburg</i>	57:89	How to Make A Graphic-80 PET from a 4016 <i>Jim Strasma</i>	54:35
Hi-Res Plotting with the VIC <i>Fred Wallace</i>	58:19	Microcomputers in a College Teaching Laboratory, Part 2 <i>Richard H. Heist, Thor Olsen, Howard Saltsburg</i>	55:59
Centronics Printer Driver for Your Microcomputer <i>Larry R. Hollibaugh</i>	58:31	Enhanced Video for OSI C1P <i>David Cantrell and Terry Terrance</i>	55:74
BANNER: A Display Program for the Color Computer <i>Bryan Christiansen</i>	58:65	Atari Meets the BSR X-10 <i>David Hayes</i>	55:82
A Versatile Hi-Res Graphics Routine for the Apple <i>Adam P. King</i>	58:77	Microcomputers in a College Teaching Laboratory, Part 3 <i>Richard H. Heist, Thor Olsen, Howard Saltsburg</i>	56:38
<b>HARDWARE</b>		Measurement of a 35mm Focal Plane Shutter <i>Mike Dougherty</i>	56:45
Add a VIA and Speech Synthesizer to the Color Computer <i>William C. Clements Jr.</i>	49:19	Microcomputer Design of Transistor Amplifiers <i>Andy Cornwall</i>	56:59
Apple Disk Drive Repair-Do it Yourself? <i>Patrick Schwab</i>	49:83	VIC RS-232 Printer <i>Michael V. Tulloch</i>	57:17
Rewriting PET ROMs <i>James Yost</i>	50:9	Microcomputers in a College Teaching Laboratory, Part 4 <i>Richard H. Heist, Thor Olsen, Howard Saltsburg</i>	57:89
Build an Apple Cart <i>Tom Fisher and Michael Straka</i>	50:55	A Full Byte for Your Apple Printer <i>Mark J. Boyd</i>	58:42
Data Transfer from AIM to PET <i>Alan K. Christensen</i>	51:11	A Home-Built Communications Interface <i>John Steiner</i>	59:44

*(MICRO's Annual Index will be continued next month.)*

## IS THERE LIFE AFTER BASIC ? YES ! WITH... COLORFORTH™

**MOVE UP FROM BASIC!** Forth is a new, high level language available now for the TRS-80® Color Computer. **COLORFORTH**, a version of fig FORTH, has an execution time as much as 10 to 20 times faster than Basic, and can be programmed faster than Basic. **COLORFORTH** is highly modular which make testing and debugging much simpler. **COLORFORTH** has been specially customized for the color computer and requires only 16K. It does not require Extended Basic. When you purchase **COLORFORTH**, you receive both cassette and RS/DISK versions, the standard fig EDITOR and an extensive instruction manual. Both versions and 75 page manual ..... \$49.95

Add \$2.00 shipping

Texas residents add 5 percent

DEALER AND AUTHOR INQUIRIES INVITED

**ARMADILLO INT'L SOFTWARE**

P. O. Box 7661

Austin, Texas 78712

Circle No. 58



Phone (512) 459-7325



# computer mail order

computer mail order east

PRINTERS	
<b>SMITH CORONA</b>	
TP-1	\$569.00
Tractor Feed	\$129.00
Ultrasonic I Typewriter	\$439.00
<b>C. ITOH (TEC)</b>	
Prowriter 8510P	\$389.00
Prowriter 8510S	\$579.00
Prowriter 1550P	\$699.00
Prowriter 1550S	\$749.00
Starwriter F10-40	\$1259.00
Printmaster F10-55	\$1649.00
<b>OKIDATA</b>	
82A	\$419.00
83A	\$659.00
84 (Parallel)	\$1049.00
84 (Serial)	\$1149.00
92	\$559.00
93	\$899.00
<b>IOB</b>	
MicroPrism	\$649.00
132 (Fully Configured)	\$1599.00
80 (Fully Configured)	\$1399.00
Call for other configurations	
<b>STAR</b>	
Gemini 10	\$349.00
Gemini 15	\$489.00
Serial Board	\$75.00
<b>DAISYWRITER</b>	
2000 (Letter Quality)	\$999.00
Tractor Feed	\$109.00
<b>DIABLO</b>	
620	\$999.00
630	\$1769.00

TeleVideo	
<b>TERMINALS</b>	
910	\$559.00
912C	\$689.00
920C	\$739.00
925C	\$719.00
950	\$929.00
<b>COMPUTERS</b>	
800A	\$1259.00
802	\$2649.00
802H	\$4695.00
806/20	\$4949.00
816/40	\$8994.00
803	\$1949.00
1602G	\$3399.00
1603	CALL

NEC	
<b>COMPUTERS</b>	
6000	CALL
8001A	\$719.00
8031	\$719.00
8012	\$549.00
<b>PRINTERS</b>	
8023	\$459.00
7710/7730	\$2249.00
3510/3530	\$1549.00
<b>MONITORS</b>	
JB-1260	\$119.00
JB-1201	\$149.00
JC-1212	\$299.00
JC-12-202	\$299.00
JC-1203	\$599.00





**EAGLE**

Call on Eagle 8 Bit & 16 Bit Computers and Software

MODEMS	
<b>HAYES</b>	
Smart	\$219.00
Smart 1200 (1200 Baud)	\$549.00
Chronograph	\$199.00
Micromodem 100	\$309.00
Micromodem II	\$279.00
Micromodem II (with term)	\$299.00
<b>NOVATION</b>	
J-Cat	\$119.00
Cat	\$144.00
D-Cat	\$159.00
103 Smart Cat	\$189.00
Apple Cat II	\$279.00
103/212 Smart Cat	\$439.00
212 Apple Cat II	\$609.00
Apple Cat II 212 Upgrade	\$309.00
<b>ANCHOR</b>	
Mark I (RS-232)	\$79.00
Mark II (Atari)	\$79.00
Mark III (TI-99)	\$109.00
Mark IV (CBM/PET)	\$125.00
Mark V (Osborne)	\$95.00
Mark VI (IBM-PC)	\$179.00
Mark VII (Auto Answer Call)	\$119.00
TRS-80 Color Computer	\$99.00
9 Volt Power Supply	\$9.00
Mark VIII	CALL

MONITORS	
<b>AMOEK</b>	
300G	\$159.00
300A	\$169.00
310G	\$179.00
310A	\$169.00
Color I	\$299.00
Color II	\$599.00
Color II A	\$799.00
Color III	\$349.00
<b>BMC</b>	
12Au 12" Green	\$79.99
1401 13" Color (Mid Res.)	\$369.00
9191J 13" Composite	\$329.00
<b>TAXAN</b>	
RGB I (Hi-Res)	\$299.00
RGB III	\$499.00
12 N Green	\$119.00
12 A Amber	\$125.00
<b>ZENITH</b>	
ZVM 121	\$99.00
ZT-1 Terminal	\$369.00
<b>SHARP</b>	
13" Color TV	\$269.00
19" Color TV	\$339.00
<b>U.S.I.</b>	
Pi 1 9" Green	\$99.00
Pi 2 12" Green	\$119.00
Pi 3 12" Amber	\$159.00
Pi 4 9" Amber	\$139.00
1400C 14" Color	\$299.00

IBM	
<b>NEC 3580PRINTER... \$1999</b>	
<b>PERCOM/TANOOM DRIVES</b>	
5 1/4" 160K Disk Drive	\$249.00
5 1/4" 320K Disk Drive	\$299.00
<b>AMOEK</b>	
310A Amber Monitor	\$169.00
310G Green Monitor	\$179.00
Amdisk (3 1/4" Drive)	\$679.00
XY Plotter	\$649.00
Color II	\$599.00
<b>ABT</b>	
Combo Card 64K	\$429.00
<b>QUBIE</b>	
PC Keyboard	\$219.00
<b>SOFTWARE</b>	
Micro Pro Word Star/Mail Merge	\$349.00
U.S. Easywriter II	\$249.00
U.S. Easywriter II	\$129.00
Peach Package (GL/AP/AR)	\$419.00
<b>PROFESSIONAL SOFTWARE</b>	
IBM-PC Word Processing	\$319.00
<b>CONTINENTAL SOFTWARE</b>	
1st Class Mail/Form Letter	\$89.00
The Home Accountant Plus	\$109.00
<b>SYNAPSE</b>	
File Manager	\$119.00
<b>IMMS</b>	
Privicode Phone	\$239.00
<b>READY FORMS</b>	
1" or 2" Address Labels (Tractor Feed)	\$9.95
15" Report Paper (Tractor Feed)	\$24.95
8 1/2" Blank White Paper (Tractor Feed)	\$19.95
8 1/2" Blank Envelopes (Tractor Feed)	\$14.95
<b>SANYO</b>	
MB 1000 Computer	\$1599.00
INCLUDES FREE SOFTWARE!	
MICROPRO-Wordstar, Calcstar, Mail Merge & Report Star.	
MB 160 Add on Drive	\$339.00
5500 Letter Quality Printer	\$699.00
<b>TIMEX SINCLAIR 1000 \$64.95</b>	
16K Memory Module	\$44.95
Vu-Calc	\$17.95
Check Book Manager	\$13.95
The Organizer	\$14.95
The Budgeter	\$13.95
Stock Option	\$14.95
Loan & Mortgage Amortizer	\$12.95
Mindware Printer	\$109.00
<b>ORBYTE SOFTWARE</b>	
Graphics	\$12.99
Home Budgeter	\$12.99
Home Inventory	\$12.99
Income Tax	\$14.99
Mega Mind	\$15.99
Salvo	\$12.99
The Quiz	\$12.99
Words	\$12.99

commodore	
	
<b>CBM 64 \$399</b>	
<b>VIC 20 \$139</b>	
1520 Color Printer/Plotter	\$169.00
1525 80 Col. Printer	\$339.00
1530 Datasette	\$69.00
1541 Single Disk Drive	\$339.00
1600 VIC Modem	\$95.00
1610 VIC Term 40	\$49.00
1650 AD/AA Modem	\$159.00
1701 14" Color Monitor	\$269.00
1311 Joystick (each)	\$6.99
1312 Paddles	\$11.99
1110 VIC 8K	\$42.00
1111 VIC 16K	\$69.00
1011 RS232 Interface	\$42.00
1211 Super Expander	\$53.00
1906 Super Alien	\$23.00
1910 Radar Rat Race	\$23.00
1917 VooDoo Castle	\$29.00
1922 Cosmic Cruncher	\$35.00
1923 Golf	\$29.00
1924 Omega Race	\$30.00
110 VIC 20 Reference Guide	\$15.00
CBM 64 Reference Guide	\$18.00
<b>EASY BUSINESS SERIES-64</b>	
Easy File	\$79.00
Easy Finance	\$39.00
Easy Mail	\$39.00
Easy Script	\$79.00
Word Machine/Name Machine	\$23.00
<b>PROGRAMMER SERIES-64</b>	
Assembler	\$39.00
Logo	\$79.00
Pilot	\$79.00
Per Emulator	\$25.00
Screen Editor	\$25.00
Video/Music Support	\$39.00
<b>ART AND MUSIC SERIES-64</b>	
Music Machine	\$25.00
Music Composer	\$25.00
Meta Music I	\$79.00
<b>COMMERCIAL DATA</b>	
Motor Mouse/20	\$23.00
Centipede/20	\$23.00
Froggee/20	\$23.00
Froggee/64	\$23.00
<b>CREATIVE SOFTWARE</b>	
Astro Blitz	\$32.00
Black Hole	\$32.00
Trashman	\$32.00
Home Finance	\$27.00
Home Inventory	\$13.00
<b>UMI</b>	
Amok	\$30.00
Meteor Run	\$40.00
Alien Blitz	\$30.00
Viterm A	\$16.00
The Alien	\$16.00
<b>SHARP</b>	
	
<b>PC-1500 POCKET COMPUTER \$169.</b>	
<b>PC-1250... \$89.00</b>	
CE150 Printer, Plotter and Cass. Interface Unit	\$172.00
CE152 Cass. Recorder	\$62.00
CE155 8K Ram Expans. Mod.	\$94.00
CE125 Printer/Micro Cass.	\$129.00
8032	\$1039.00
4032	\$739.00
8096 Upgrade Kit	\$369.00
9000	\$1499.00
2031	\$449.00
4040	\$949.00
8050	\$1279.00
8250	\$1639.00
9060 (5 Meg. HD)	\$1999.00
9090 (7.5 Meg. HD)	\$2199.00
4022	\$389.00
8023	\$589.00
8300	\$1489.00
Spell Master	\$99.00
Z Ram adds CP/M & 64K	\$549.00
Silicon Office	\$749.00
Calc Result	\$159.00
The Manager	\$209.00
The Soft Rom	\$129.00
Jinsam	CALL
ADA 1600 CBM to Paral. Inter.	\$89.00
ADA 1450 CBM to Serial Interface	\$99.00
<b>PROFESSIONAL SOFTWARE</b>	
Power	\$79.00
Info Pro	\$219.00
Word Pro 2 plus	\$159.00
Word Pro 3 plus	\$199.00
Word Pro 4 plus	\$299.00
Word Pro 5 plus	\$299.00
Administrator	\$379.00
Word Pro 64	\$79.95
<b>CAROCO</b>	
VIC 20 & CBM 64	
Light Pen	\$32.00
Cassette Interface	\$29.00
Parallel Printer Interface	\$64.00
3 Slot Expans. Interface (20 only)	\$32.00
6 Slot Expans. Interface (20 only)	\$79.00
<b>HES</b>	
Shemus (ROM)	\$29.00
Protector (ROM)	\$32.00
Robot Panic (ROM)	\$29.00
Pirates (ROM)	\$29.00
HES Writer (ROM)	\$29.00
<b>PANASONIC</b>	
JR200J 32K Pers. Computer	\$309.00
<b>MONITORS</b>	
TR-120 12" Hi-Res Green	\$159.00
CT-160 10" Dual Mode Color	\$299.00
DT-D1000 10" RGB	\$349.00
DT-D1300 13" RGB/Composite	\$429.00

IBM	
<b>IBM 3580PRINTER... \$1999</b>	
<b>PERCOM/TANOOM DRIVES</b>	
5 1/4" 160K Disk Drive	\$249.00
5 1/4" 320K Disk Drive	\$299.00
<b>AMOEK</b>	
310A Amber Monitor	\$169.00
310G Green Monitor	\$179.00
Amdisk (3 1/4" Drive)	\$679.00
XY Plotter	\$649.00
Color II	\$599.00
<b>ABT</b>	
Combo Card 64K	\$429.00
<b>QUBIE</b>	
PC Keyboard	\$219.00
<b>SOFTWARE</b>	
Micro Pro Word Star/Mail Merge	\$349.00
U.S. Easywriter II	\$249.00
U.S. Easywriter II	\$129.00
Peach Package (GL/AP/AR)	\$419.00
<b>PROFESSIONAL SOFTWARE</b>	
IBM-PC Word Processing	\$319.00
<b>CONTINENTAL SOFTWARE</b>	
1st Class Mail/Form Letter	\$89.00
The Home Accountant Plus	\$109.00
<b>SYNAPSE</b>	
File Manager	\$119.00
<b>IMMS</b>	
Privicode Phone	\$239.00
<b>READY FORMS</b>	
1" or 2" Address Labels (Tractor Feed)	\$9.95
15" Report Paper (Tractor Feed)	\$24.95
8 1/2" Blank White Paper (Tractor Feed)	\$19.95
8 1/2" Blank Envelopes (Tractor Feed)	\$14.95
<b>SANYO</b>	
MB 1000 Computer	\$1599.00
INCLUDES FREE SOFTWARE!	
MICROPRO-Wordstar, Calcstar, Mail Merge & Report Star.	
MB 160 Add on Drive	\$339.00
5500 Letter Quality Printer	\$699.00
<b>TIMEX SINCLAIR 1000 \$64.95</b>	
16K Memory Module	\$44.95
Vu-Calc	\$17.95
Check Book Manager	\$13.95
The Organizer	\$14.95
The Budgeter	\$13.95
Stock Option	\$14.95
Loan & Mortgage Amortizer	\$12.95
Mindware Printer	\$109.00
<b>ORBYTE SOFTWARE</b>	
Graphics	\$12.99
Home Budgeter	\$12.99
Home Inventory	\$12.99
Income Tax	\$14.99
Mega Mind	\$15.99
Salvo	\$12.99
The Quiz	\$12.99
Words	\$12.99

IBM	
<b>IBM 3580PRINTER... \$1999</b>	
<b>PERCOM/TANOOM DRIVES</b>	
5 1/4" 160K Disk Drive	\$249.00
5 1/4" 320K Disk Drive	\$299.00
<b>AMOEK</b>	
310A Amber Monitor	\$169.00
310G Green Monitor	\$179.00
Amdisk (3 1/4" Drive)	\$679.00
XY Plotter	\$649.00
Color II	\$599.00
<b>ABT</b>	
Combo Card 64K	\$429.00
<b>QUBIE</b>	
PC Keyboard	\$219.00
<b>SOFTWARE</b>	
Micro Pro Word Star/Mail Merge	\$349.00
U.S. Easywriter II	\$249.00
U.S. Easywriter II	\$129.00
Peach Package (GL/AP/AR)	\$419.00
<b>PROFESSIONAL SOFTWARE</b>	
IBM-PC Word Processing	\$319.00
<b>CONTINENTAL SOFTWARE</b>	
1st Class Mail/Form Letter	\$89.00
The Home Accountant Plus	\$109.00
<b>SYNAPSE</b>	
File Manager	\$119.00
<b>IMMS</b>	
Privicode Phone	\$239.00
<b>READY FORMS</b>	
1" or 2" Address Labels (Tractor Feed)	\$9.95
15" Report Paper (Tractor Feed)	\$24.95
8 1/2" Blank White Paper (Tractor Feed)	\$19.95
8 1/2" Blank Envelopes (Tractor Feed)	\$14.95
<b>SANYO</b>	
MB 1000 Computer	\$1599.00
INCLUDES FREE SOFTWARE!	
MICROPRO-Wordstar, Calcstar, Mail Merge & Report Star.	
MB 160 Add on Drive	\$339.00
5500 Letter Quality Printer	\$699.00
<b>TIMEX SINCLAIR 1000 \$64.95</b>	
16K Memory Module	\$44.95
Vu-Calc	\$17.95
Check Book Manager	\$13.95
The Organizer	\$14.95
The Budgeter	\$13.95
Stock Option	\$14.95
Loan & Mortgage Amortizer	\$12.95

# computer mail order

**FRANKLIN**



Call on FRANKLIN Computers.  
Disk Drives, Software and  
Special System Offers!

**MICRO-SCI**  
DISK DRIVES FOR  
APPLE & FRANKLIN

A2.....	\$269.00
A40.....	\$349.00
A70.....	\$459.00
C2 Controller.....	\$79.00
C47 Controller.....	\$89.00

**RANA DISK DRIVES**

Elite I plus (Apple/Franklin).....	CALL
1000 (Atari).....	\$349.00

**SYSCOM**

48K Color Computer  
APPLE COMPATIBLE  
**\$629**

**VISICORP**

for Apple, IBM & Franklin

Visidex.....	\$189.00
Visifile.....	\$189.00
Visiplot.....	\$159.00
Visiterm.....	\$89.00
Visitrend/Plot.....	\$229.00
Visschedule.....	\$229.00
Desktop Plan.....	\$189.00
Visicalc (Apple II, CBM, IBM).....	\$179.00

Visicorp prices for IBM may vary slightly.

**BRODERBOND**

Apple Panic.....	\$23.00
David's Magic.....	\$27.00
Star Blazer.....	\$25.00
Arcade Machine.....	\$34.00
Chopflifer.....	\$27.00
Serpentine.....	\$27.00

**INFOCOM**

Deadline (Apple, Atari, IBM).....	\$35.00
Star Cross.....	\$29.00
Zork I, II or III.....	\$29.00

**MPC**

Bubdisk (128K Non Volatile).....	\$649.00
----------------------------------	----------

**AXLON**

Apple/Franklin 128K Ram.....	\$399.00
Apple/Franklin Ram Disk.....	\$999.00

**KRAFT**

Apple Joystick.....	\$44.00
---------------------	---------

**CONTINENTAL**

Tax Advantage (Apple/Atari).....	\$45.00
Home Acct. (Apple/Atari).....	\$59.00
1st Class Mail/Form Letter (Apple).....	\$79.00
The Book of Apple.....	\$14.95
The Book of Atari.....	\$14.95
The Book of Apple Graphics.....	\$14.95

**PERCOM**

**DISK DRIVES FOR ATARI**

AT 88-S1.....	\$399.00
AT 88-A1.....	\$299.00
AT 88-S2.....	\$649.00
RFD 40-S1.....	\$549.00
RFD 40-A1.....	\$349.00
RFD 40-S2.....	\$889.00
RFD 44-S1.....	\$679.00
RFD 44-S2.....	\$999.00

**FLOPPY DISKS**

**MAXELL**

MD I (Box of 10).....	\$32.00
MD II (Box of 10).....	\$44.00
FD I (8").....	\$40.00
FD II (8"DD).....	\$50.00

**VERBATUM**

5 1/4" SS DD.....	\$26.00
5 1/4" DS DD.....	\$36.00

**ELEPHANT**

5 1/4" SS SD.....	\$19.99
5 1/4" SS DD.....	\$24.99
5 1/4" DS DD.....	\$29.99

**HEAD**

Disk Head Cleaner.....	\$14.95
------------------------	---------

**SIRIUS**

Bandits (Apple).....	\$28.00
Beer Run (Apple).....	\$24.00
Free Fall (Apple).....	\$24.00
Snakers (Apple).....	\$24.00
Snake Byte (Apple).....	\$24.00
Fast Eddie (Atari).....	\$21.00
Turmoil (Atari).....	\$21.00
Deadly Duck (VIC).....	\$21.00

**INTERFACES & ACCESSORIES**

80 Col. Apple Card.....	\$159.00
Apple Parallel Printer Interface.....	\$69.00
Atari 850 to Parallel Printer Cable.....	\$29.00
RS232-RS232 Cables.....	\$29.00
Centronics Parallel-Parallel Cables.....	\$29.00
Call on IBM, Osborne, Daisywriter, Atari, Commodore, Apple and Franklin Interface Cards, Cables and accessories	

**HEWLETT**

**PACKARD**



**41CV**  
**\$209**

**HP 75.....\$749.**

HP 41C (Free Memory Module).....	\$149.00
HP 10C.....	\$59.00
HP 11C.....	\$72.00
HP 12C.....	\$99.00
HP 15C.....	\$99.00
HP 16C.....	\$99.00

**For HP 41/41CV**

HP11L Module.....	\$99.00
HP11L Cassette or Printer.....	\$359.00
Card Reader.....	\$144.00
Extended Functions Module.....	\$64.00
Time Module.....	\$64.00
Mathematics Pac.....	\$26.50
Real Estate Pac.....	\$40.00



**HOME COMPUTERS**

**ATARI 800**

48K

**\$489**



**ATARI 600-16K ATARI 1200-64K**

Call for price and availability on these  
two new Computers from Atari.

810 Disk Drive.....	\$429.00
Inhome Keyboard Kit Atari 400.....	\$89.00
1010 Program Recorder.....	\$74.00
1020 40 Col. Printer/Plotter.....	\$269.00
1025 80 Col. Printer.....	\$469.00
830 Acoustic Modem.....	\$159.00
850 Interface Module.....	\$169.00
CX40 Pr. Joysticks.....	\$16.00
CX418 Home Manager Kit.....	\$69.00
CX419 Bookkeeper Kit.....	\$195.00
CX482 Educator Kit.....	\$129.00
CX483 Programmer Kit.....	\$54.00
CX488 Communicator Kit.....	\$229.00
CX7101 Entertainer Kit.....	\$69.00
Invitation to Programming I.....	\$18.00
Invitation to Programming II.....	\$28.00
Invitation to Programming III.....	\$20.00
4002 Basic Language.....	\$42.00
4903 Assembler Editor.....	\$47.00
8121 Micro Assembler.....	\$69.00
8126 Micro Soft.....	\$69.00
405 Pilot (Edu).....	\$105.00
4018 Pilot (Home).....	\$72.00
8036 Atari Writer.....	\$79.00
404 Word Processor.....	\$119.00
5059 Visicalc.....	\$159.00

**ATARI**

Pacman.....	\$33.00
Centipede.....	\$33.00
Defender.....	\$33.00
Galaxian.....	\$33.00
Missile Command.....	\$29.00
Star Raiders.....	\$33.00
Caverns of Mars.....	\$32.00
Dig Dug.....	\$33.00
Donkey Kong.....	CALL
E.T. Phone Home.....	\$39.00
Eastern Front (1941).....	\$39.00
QIX.....	\$33.00
Superman III.....	\$39.00
Star Trux.....	\$33.00
Asteroids.....	\$29.00
Basketball.....	\$29.00
Computer Chess.....	\$29.00
Juggles House.....	\$23.00
My First Alphabet.....	\$29.00

**APX**

Text Formatter.....	\$18.50
Family Budgeter.....	\$18.50
Eastern Front.....	\$24.00
Family Cash.....	\$18.50
Jukebox.....	\$13.50
Downhill.....	\$18.50
Outlaw.....	\$18.50
Holy Grail.....	\$24.00
Player Piano.....	\$18.50
Keyboard Organ.....	\$18.50
Number Blast.....	\$13.50
Frogmaster.....	\$18.50
747 Land Simulator.....	\$18.50
Bumper Pool.....	\$13.50

**ON-LINE**

Jawbreaker.....	\$27.00
Softporn.....	\$27.00
Wizard and Princess.....	\$29.00
The Next Step.....	\$34.00
Mission Asteroid.....	\$22.00
Mouskattack.....	\$31.00
Frogger.....	\$31.00
Cross Fire (ROM).....	\$36.00

Some ON-LINE Products are also available for Apple and IBM. Call for information.

**SYNAPSE**

File Manager 800 plus.....	\$69.00
Chicken (ROM).....	\$34.00
Picnic Paranoid(ROM).....	\$34.00
Claim Jumper (ROM).....	\$34.00
Slime (ROM).....	\$34.00
Shamus (ROM).....	\$34.00
Protector (ROM).....	\$34.00
Dodge Racer (C/D).....	\$26.00
Nautilus (C/D).....	\$26.00
Shadow World (C/D).....	\$26.00
Survivor (C/D).....	\$26.00
Dreibus (C/D).....	\$26.00
Necromancer (C/D).....	\$26.00
Pharaoh's Curse (C/D).....	\$26.00
Fort Apocalypse (C/D).....	\$26.00
Page 6.....	\$19.00
Assembler.....	\$30.00
Disk Manager.....	\$24.00

**DATASOFT**

Pacific Coast Highway.....	\$25.00
Canyon Climber.....	\$25.00
Tumble Bugs.....	\$25.00
Shooting Arcade.....	\$25.00
Clowns and Balloons.....	\$25.00
Graphic Master.....	\$30.00
Graphic Generator.....	\$13.00
Micro Painter.....	\$25.00
Text Wizard.....	\$79.00
Spell Wizard.....	\$64.00
Bishop's Square.....	\$25.00
Sands of Egypt.....	\$25.00
Moon Shuttle.....	\$25.00
Zaxxon.....	\$29.00

**ALIEN**

Atari Voice Box.....	\$119.00
Apple Voice Box.....	\$149.00

**MEMORY**

Aslon 32K Ram.....	\$89.00
Aslon 48K Ram.....	\$139.00
Aslon 128K Ram.....	\$399.00
Intec 32K Board.....	\$74.00
Intec 48K Board.....	\$99.00
Intec 64K Board (400 only).....	\$149.00

**WICO**

Joystick.....	\$24.95
Famous Red Ball.....	\$26.95
Apple Trackball.....	\$59.00
Atari/VIC Trackball.....	\$55.00
Apple Adapter.....	\$16.00

**ATARI 400**

16K.....	\$199
32K.....	\$274
48K.....	\$299
64K.....	\$359

Non-Atari Ram

**CB8**

Krazy Shoot Out.....	\$32.00
Krazy Krusters.....	\$32.00
Krazy Antics.....	\$32.00
Krazy Patrol.....	\$32.00
Sick Stand.....	\$5.99

**EPYX**

Crush, Crumble & Chomp.....	\$24.00
Crypt of the Inhead.....	\$24.00
Curse of Ra.....	\$16.00
Dairstones & Ryn.....	\$16.00
Invasion Orion.....	\$19.00
King Arthur's Heir.....	\$24.00
Morloc's Tower.....	\$16.00
Rescue at Rigel.....	\$24.00
Ricochet.....	\$16.00
Star Warrior.....	\$29.00
Temple of Apshe.....	\$29.00
Upper Reaches of Apshe.....	\$16.00

**SPINNAKER**

Snooper Troops#1.....	\$34.00
Snooper Troops#2.....	\$34.00
Face Maker.....	\$24.00
Story Machine.....	\$24.00
Delta Drawing.....	\$45.00
Rhymes and Riddles.....	\$21.00
Kinder Comp.....	\$21.00

**ROKLAN**

Wizard of War (ROM).....	\$34.00
Deluxe Invader (ROM).....	\$29.00
Gorf (ROM).....	\$34.00

**FIRST STAR**

Astro Chase.....	\$25.00
------------------	---------

**BIG 5**

Miner 49er.....	\$35.00
-----------------	---------

**GAMESTAR**

Baja Buggies.....	\$24.95
Football.....	\$24.95

**BUOGECO.**

Raster Blaster.....	\$24.95
---------------------	---------

**L.J.K.**

Letter Perfect 40/80 Col. Disk.....	\$109.00
Letter Perfect 40 Col. Rom.....	\$179.00
Letter Perfect 80 Col. Rom.....	\$179.00
Data Perfect 40/80 Col. Disk.....	\$79.00
Mail Merge.....	\$21.95

CALL FOR APPLE/L J K PRODUCTS

**BIT 3**

80 Col. Card for Atari 800.....	\$279.00
---------------------------------	----------

We also stock software by:  
Adventure International,  
Eduware, Creative Soft-  
ware, Dorsett Educational,  
IDSI, Romox and Artworx.  
Call for details and prices.

**computer mail order east**

**800-233-8950**

IN PA. CALL (717)327-9575

DEPT 415, 477 E. Third St. Williamsport, PA 17701

No risk, no deposit on C.O.D. orders. Pre-paid orders receive free shipping within the UPS Continental United States Delivery Zone, with no waiting period for certified checks or money orders. Add 3% (minimum \$3.00) shipping and handling on all C.O.D. orders. Larger shipments may require additional charges. NV and PA residents add sales tax. All items subject to availability and price change. NOTE: We stock manufacturer's and third party software for most all computers on the market. Call today for our new catalog.

computer mail order west

# BUSIWRITER



## BUSIWRITER A Honey of a Word Processor

### Why word processors?

Word processors allow the user to quickly and easily create letters, memos, notes, reports, term papers, manuals, poetry and any other written information using the memory of the computer as a pencil and paper. The computer display or terminal acts as a window through which the user views the information as it is entered. The outstanding advantage of using BUSIWRITER is that it acts not only as a pencil and paper but as a perfect eraser and automatic typewriter.

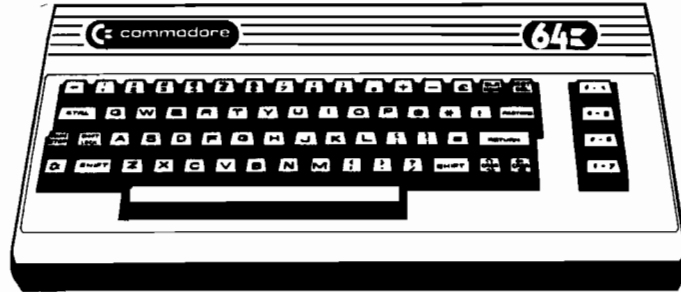

### For Commodore CBM-64

Commodore 1515, 1525, Epson, C. Itoh, Qume, Diablo, NEC Spinwriter, Starwriter, Prowriter, Okidata, Microline, Gemini-10

### And many more printers

## BUSIWRITER The Queen Bee of Word Processors

BUSIWRITER allows the user to quickly and easily make any number of alterations to the text. BUSIWRITER will instantly reformat your text and show you exactly and continuously how the final output will appear. BUSIWRITER has more functions than any other known microcomputer word processor. With BUSIWRITER assisting in the entry of text, providing a **20 page memory** and performing an enormous number of editing/composing functions, the preparation of written data is far faster and outstandingly more accurate than if it were prepared by hand.



## BUSIWRITER With the Sting Removed from the Prices

**BUSIWRITER 64** ..... only **\$99.00** for the CBM 64

**BUSIWRITER AVAILABLE NOW FROM YOUR LOCAL DEALER**

**(800) 227-9998**

**FOR THE NAME OF YOUR NEAREST DEALER**

California, Canada, Alaska and Hawaii please call (415) 965-1735



### Skyles Electric Works

231G South Whisman Road  
Mountain View, CA 94041

Europe please contact Supersoft, Winchester House, Harrow Wealdstone, England HA3 7SJ, Tel. 01 861 1166



Product Name: **HUMBUG**  
Equip. req'd: TRS-80 Color Computer with 16K  
Price: \$39.95 on cassette  
Manufacturer: STAR-KITS  
P.O. Box 209  
Mt. Kisco, NY 10549

**Description:** *HUMBUG* is an exceptionally complete and well-written assembly-language debug monitor for the Color Computer. It requires 4K of read/write memory anywhere in the machine and is totally position-independent. *HUMBUG* can reside in ROM, and then uses approximately 60 bytes of read/write memory for workspace and 256 bytes for two separate stacks. Almost any screen display can be printed at any of five selectable baud rates. Memory can be dumped in ASCII, hex, or disassembler format, as well as a continuous ASCII text string. Other memory commands allow video display of any 512-byte section of memory, memory examine/change, memory compare, and test memory. *HUMBUG* will save assembly-language programs on tape, but the major input/output mode is an RS-232 data stream in the Motorola checksum S1-S9 format. The debug features include single-step and breakpoint operation and register examine/change.

**Pluses:** The "desemblem" command is not a full disassembler, but it dumps memory in disassembly format to ease code entry. The FIND command prints the byte previous to and two bytes following the specified byte. For example, FIND \$16 will list every LBSR command in the program being analyzed — by location! The ANALYZE TAPE command reports the start and end addresses, the transfer address, and record type of any block-recorded tape. Finally, MOVE *HUMBUG* moves *HUMBUG* anywhere in read/write memory, and WHERE *HUMBUG* reports the location of the current version.

**Minuses:** *HUMBUG* does not read machine-language tapes, and the documentation on I/O control needs step-by-step examples. Also, the listing was photo-reduced, then part of each comment was truncated to make room on the page.

**Documentation:** A 30-page book provides a full listing and covers operation of *HUMBUG*, memory requirements, compatibility with BASIC, and protection of *HUMBUG* when BASIC is running. This documentation is well done and very thorough.

**Skill level required:** Experienced assembly-language programmers will derive the most benefit from this program, but the abundance of commands and excellent documentation will help novices learn assembly-language programming.

**Reviewer:** Ralph Tenny

**Editorial Comment:** This reviewer commends STAR-KITS for giving a full listing and for facing the software piracy

(Continued on page 112)

## ACORN 68000 ATTACHED PROCESSOR FOR THE APPLE II™

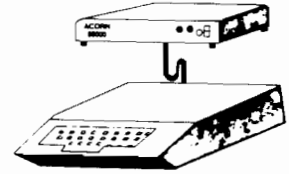

\$1495

### HARDWARE

- 68000 Microcomputer with 16 MHz clock
- 131,072 Bytes of RAM Memory
- 32,768 Bytes of ROM Memory
- Two RS 232c serial ports up to 9,600 bps
- One million bps interface with APPLE™
- Seven levels of vectored interrupts
- Real time clock and timer
- Separate case and power supply

### SOFTWARE

- Uses only one peripheral slot in the APPLE™
  - Invisible operation with APPLESOFT or PASCAL
  - Compatible with Compilers and 6502 Assemblies
  - 68000 Assembly Language Development System
- Write or call for a free brochure or send \$10 for 100 page users manual (refunded with order for ACORN)

### ACORN SYSTEMS INC.

4455 TORRANCE BLVD., #108 • TORRANCE, CA 90503  
Telephone (213) 371-6307

\*Apple, Apple II and Applesoft are the trademarks of Apple Computer Co  
Circle No. 60

## SOPHISTICATED TELE-COMMUNICATION IS HERE

### THE COMMUNICATOR for 4.0 Commodore Computers

#### JIM STRASMA'S REVIEW:

"THE BEST TERMINAL PACKAGE I'VE SEEN YET"

By April 1 (maybe sooner) It Will Be Even Better

SPEEDS UP TO 9600 BAUD

XON — XOFF

TRUE CTRL KEY (we do our own keyboard scan)

**THE HARDWARE** — A printed circuit board; easily installed in the CBM. It uses no CBM connectors; gives a serial port with true RS232C standard.

#### THE SOFTWARE —

- Emulates the ADDS Regent 100, ADM 31 and/or the TeleVideo 950.1 Or choose the VT100 model for use with DEC and VAX computers.
- Runs coresident with BASIC programs; lets BASIC programs and program on host computer communicate to develop really sophisticated communication and control capabilities.
- The program is on ROM at either address; no disk loading required. Uses only 512 bytes of RAM; will relocate itself around any other machine language program at top of memory.
- Will upload and download and run BASIC programs. With BASIC program will upload and download standard data files. 100 page manual gives program listing for BASIC programs.

Excellent text editor designed to work with THE COMMUNICATOR

THE COMMUNICATOR \$200

Text Editor \$40

1200 baud modems beginning at low, low \$385, and even less when purchased with THE COMMUNICATOR

AMPLIFY, INC.

2325 Macbride, Iowa City, Iowa 52240 319-337-8378

1 trademarks Addis Regent, Inc., Lear Liegler, Inc., Televideo Systems, Inc.

Circle No. 61

# SOFTWARE FOR THE HARDWARE

## THE PROFESSIONAL'S CHOICE FORTH — A Tool for Craftsmen!

It has been said that if Chippendale had made programs he would have used FORTH as his tool. If you want to learn how to program, use a teaching language—PASCAL or BASIC. If you know how to program, use a language designed for craftsmen—FORTH.

### FORTH Systems

For all FLEX systems: 6800 & 6809. Specify 5" or 8" diskette and hardware configuration. For standalone versions, write or call.

- \*\* tFORTH—extended fig-FORTH (1 disk) \$100 (\$15)
- \*\* tFORTH + —extended more! (3 5" or 2 8" disks) \$250 (\$25)
- tFORTH + includes 2nd screen editor, assembler, extended data types and utility vocabularies, GOING FORTH CAI course on FORTH, games, and debugging aids.

### TRS-80 COLORFORTH — 10K ROM Pack

Full screen editor. Will work on 4K, 16K, or 32K systems \$110 (\$20). Disk versions available.

### Applications Programs

- \*\* firmFORTH 6809 tFORTH + only \$350 (\$10)
- For target compilations to rommable code. Deletes unused code and unneeded dictionary heads. Requires tFORTH +.
- \*\* TINY PASCAL compiler in FORTH. 6800/09 \$75 (\$20)
- \*\* FORTH PROGRAMMING AIDS: Extensive debugging, decompiling, and program analysis tools. \$150 (\$10)

Manuals alone, price in (.). Add \$5/system for shipping. \$12 for foreign air.

### Talbot Microsystems

1927 Curtis Ave., Redondo Beach, CA 90278  
(213) 376-9941

(TM) tFORTH, COLORFORTH and firmFORTH are trademarks of Talbot Microsystems.  
(TM) FLEX is a trademark of Technical Systems Consultants.

Circle No. 62

## COMPUTER ACCESSORIES

### ERRORS—DOWNTIME—SERVICE

A speck of dust, dirt, or magnetic oxide on the read/write head of your floppy disk can cause data transfer errors, a disk crash, or even a costly disk drive failure. Regular use of Perfectdata head cleaning diskettes can keep your drive heads clean and your system up and running. The Perfectdata system can be used on single or dual-sided floppy disk drives. (Comes complete with 2 cleaning diskettes, a 4 oz. bottle of CS-85 cleaning solution, and full instructions.)

- 5.25" Disk Drive Cleaning Kit \$22.75
- 8" Disk Drive Cleaning Kit \$22.75

### ORGANIZE AND PROTECT YOUR DISKETTES

Organize your diskettes with an innovative Concepts Flip 'N' File from Mercury Micro. Holds up to 50 diskettes in a handsome smoke-colored transparent plastic case.

- Case for 5.25" Diskettes \$23.75
- Case for 8" Diskettes \$29.75

### WHAT'S YOUR FAVORITE NUMBER?

New for spring. Top quality shirts with "64" or "20" printed in large numerals on both front and back. 50/50 blend **will not shrink**. Specify color and size and number choice. Available in red or blue, S-M-L-XL.

\$7.50 each

### ORDERING INFORMATION

Phone (301) 994-1122

### SHIPPING

Add \$1.50 to all orders for shipping. We pay balance for UPS service on all orders. Add \$2.00 for COD. Maryland residents please add 5% state sales tax.

WRITE OR CALL FOR FREE COMPUTER ACCESSORY CATALOG: SURGE PROTECTORS, DUST COVERS, BOOKS, DISK MAINTENANCE, BLANK MEDIA AND MUCH MORE.



Mercury Micro Inc.  
Dept. F  
Cherry Field Road  
Drayden, Md. 20630

Circle No. 63

## Reviews (continued)

issue head-on. In effect, they say "Here's how to copy HUMBUG; don't give copies away or we will sue you!" By furnishing the listing and very complete documentation, STAR-KITS has made it possible for the user to derive the fullest value possible from his investment, and the resulting product is thereby more durable and valuable.

Product Name: **Readtest**

Equip. req'd: 64K TRS-80 Color Computer, one disk drive, FLEX DOS

Price: \$54.95, \$74.95 with source

Manufacturer: Frank Hogg Laboratory  
770 James St.  
Syracuse, NY 13203

Author: Dale Puckett

**Description:** *Readtest*, a utility for writers, is a text analysis program that reads standard FLEX text files from disk and generates a written report on your terminal or printer. The program gives you the number of words, lines, sentences, pronouns, proper nouns, and affixes in your text, and also computes the average sentence length. The report rates your material from very difficult to very easy to read, and classifies it from dramatic to dull. You are told what percentage of persons in the U.S. could read your material and what grade-level reading skill is required to understand it. The program is based on Dr. Rudolf Flesch's book, "The Art of Plain Talk," and a statistical readability formula.

**Pluses:** The report display conforms to your terminal standards automatically and wraps words on the screen. The program-generated report is easy to understand. *Readtest* is not copy-protected and takes up only 24 256-byte sectors on a FLEX-formatted disk. It is written in position-independent code and can be loaded and run anywhere in memory.

**Minuses:** Although *Readtest* is written in assembly language, it can take several minutes to generate a report with a 25000-word text file. *Readtest* runs under the FLEX operating system only and you need a standard FLEX editor to generate text for the program.

**Documentation:** The author has prepared a thorough, comprehensive, and easy-to-read manual that details each command, explains how the program works, how to adapt it to other systems, and how to effectively interpret the results of the printed report. The documentation is over 13 pages long. Even if you don't buy the source code, *Readtest's* routines are explained in detail. A demonstration text file is included to show how *Readtest* works and how not to write.

**Skill level required:** No special techniques or abilities required.

**Reviewer:** Bill Ball

Product Name: **HESMON — VIC Monitor Cartridge**  
Equip. req'd: VIC-20 (5K or more)

Price: \$39.95  
 Manufacturer: Human Engineered Software  
 71 Park Lane  
 Brisbane, CA 94005  
 Author: Dr. Terry Peterson

**Description:** *HESMON* is a 6502 machine-language monitor for the VIC-20 similar to the various versions of MICROMON or SUPERMON available for the PET. *HESMON* comes on a cartridge that plugs into the VIC's expansion port. It has nearly 30 commands — almost double the number available in Commodore's VICMON. In addition to the standard commands (e.g., A,B,C,D,F,G,H,I,J,L,M,N,Q,R,S,T,W, and X) found in VICMON, *HESMON* has hex-to-decimal conversion, hex arithmetic, a memory test, a color test, and an external relinker that enables you to convert code from one machine to another if you have a table of corresponding memory locations. Output may be optionally diverted to a printer or disk. Both forward and reverse scrolling are implemented.

**Pluses:** *HESMON* is a great value — nearly twice the commands of VICMON for only two-thirds the price (\$39.95 versus \$59.95). It is completely compatible with BASIC, and there is no need to protect zero-page as with VICMON.

**Minuses:** *HESMON* will not disassemble itself, or allow you to look at it or transfer it in any manner. This is unfortunate because there is much that could be learned from this fine implementation.

**Documentation:** The 32-page manual is clearly written and contains many examples. The first section, entitled "If You've Never Used a 'Machine-Language Monitor' Before," is quite unique and well done.

**Skill level required:** Basic understanding of 6502 machine language.

**Reviewer:** David Malmberg

Product Name: **Dual Plug-in Interface Board, p/n 276-163**  
 Equip. req'd: TRS-80 Color Computer, breadboarding tools, and materials as required for project  
 Price: \$4.95  
 Manufacturer: Radio Shack

**Description:** Although Radio Shack did not intend that p/n 276-163 be used with the Color Computer, and the documentation does not suggest such a use, this product is a low-cost source for prototyping and expansion boards for the Color Computer. It is a 4.25" x 5.25" glass epoxy board with a 40-pin card-edge connector on either end. Both ends are a precise mechanical and electrical fit for the computer's expansion port. The board will hold 15 normal-sized ICs or varying numbers of larger ICs, including .6"-wide ICs. There is also a modest space for discrete components and two power bus lines are furnished.

(Continued on next page)

### 32K CMOS STATIC RAM BOARD for SYM/AIM

Models MB-132/32K, \$299

/16K \$241, /8K \$197



#### Features:

- 200ns Low Power CMOS, STATIC RAM
- Extends your expansion connector
- Plug compatible with 2716 EPROMS
- First 8K are jumper selectable
- Entire board may be bank-switched
- G-10 Glass epoxy, Full solder mask, Gold fingers
- Full 1-year limited warranty

### I/O EXPANSION BOARD for the SYM/AIM

and other microcomputers that use 6522 VIAs for I/O and do not provide full address decoding on board. This board has physical space for four additional 6522 VIAs, and provides additional decoding for a total of 16 devices. Connectors for all I/O lines, and further expansion are included. All 6522 functions are available, with no interference with previous functions of the original VIA. Two versions of this board are available. The I/OX-122 mounts above, and directly plugs into, an on-board 6522 socket, and relocates the original VIA to the expansion board. Where there are space limitations, the I/OX-222 uses a dip header and an 8" cable for remote installation.

I/OX-122 \$60  
 I/OX-222 \$72

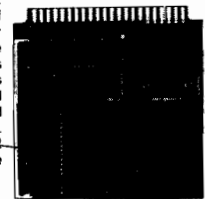

**REAL-TIME CLOCK/CALENDAR \$60** Write for Info.  
 P.O. Box 1019 • Whittier, CA 90609 • (213) 941-1383

ALTERNATIVE  
 ENERGY  
 PRODUCTS

Circle No. 65

Circle No. 66

### 6809 CPU single board computer

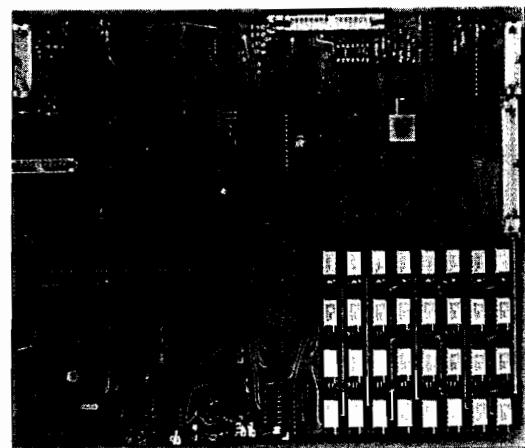

- \*192KB RAM included, sockets for 64KB more
- \*84X24 display of a 7X12 character font
- \*Keyboard interface for an un-encoded switch matrix
- \*Floppy controller for two 5" drives, single or double sided

The FLEX operating system is supported by our device drivers.

FLEX, trademark Technical Systems Consultants, Inc.

Commented source code of all EPROM contents is supplied.

For more information, send a stamped self-addressed envelope and we will send you a configuration guide that explains how to set-up a system. An assembled board is purchased by sending check or money order for \$735 per board. (California add 6% sales tax).

**Chandler Microsystems**

22051 COSALA  
 MISSION VIEJO, CA 92691

- \*Parallel printer port
- \*Serial I/O port
- \*General purpose 8-bit I/O
- \*Parallel expansion port

PET / CBM™

# SOFTWARE SELECT!

**8032**  
DISPLAY

OR

**4032**  
DISPLAY

FROM THE KEYBOARD OR PROGRAM  
NOW RUN WORD PRO 3 OR WORD PRO 4

## FROM THE SAME MACHINE

Available for either 4000 or 8000 Series

ALSO:

For **2001 / 3000** Series Computers

Operate these Models in a Full **8032** Like  
Display For Word Pro 4\*  
and all other 80 Column Software  
All installation instructions included.

### EXECOM CORP.

1901 Polaris Ave.  
Racine, WI 53404  
Ph. 414-632-1004

PET/CBM a trademark of Commodore Business Machines  
\*trademark of Professional Software, Inc.

Circle No. 67

# UV EPROM ERASER

- \* Erases over 15 EPROMS - 15 minutes erase time
- \* Element life 7700 hours
- \* Intensity: 12Ws 1/2cm<sup>2</sup> at 1"
- \* Erases all UV EPROMS (2716, 2732, 2516, 2532, etc.)



## \$49.95\*

\*HOBBY MODEL

### INDUSTRIAL MODEL

QUV-T8 / 2N

\$68.95

WITH TIMER AND  
SAFETY SWITCH

QUV-T8 / 2T

\$97.50

### INTELLIGENT PROGRAMMER STAND ALONE RS-232

- \* RELIABLE
- \* EASY COPY (No external equipment needed)
- \* USER FRIENDLY

COMPATIBLE:  
IBM PC, TRS-80, APPLE, CPM,  
FLEX, TEKTRONICS, MOS

### (MCS-48)

PROGRAMMING  
PRICE INCLUDES  
PERSONALITY MODULE

## \$489.00

PROGRAMS: 2508, 2516, 2532, 2716, 27C16, 27C32,  
2732, 2732A, 2758, 8748, 8749H, 8748H

OPTIONAL MODULES: 2564, 2764, 8755A, 8741

- \* STAND ALONE, CRT, OR COMPUTER CONTROL
- \* UPLOAD/DOWNLOAD IN MOTOROLA OR INTEL HEX FORMAT
- \* MICROPROCESSOR BASED \* 4 K INTERNAL RAM
- \* 90 DAY PARTS & LABOR WARRANTY ON ALL PRODUCTS

SOON TO BE RELEASED:

**PROMPRO-8 128K Version \$689.**

**MONEY BACK GUARANTEE**

### LOGICAL DEVICES INC.

781 W. OAKLAND PARK BLVD. • FT. LAUDERDALE, FL 33311

Phone Orders (305) 974-0967 • TWX: 510-955-9496

SEE US AT COMDEX SPRING - BOOTH #3019

Circle No. 68

## Reviews (continued)

**Pluses:** Low cost and good construction allows near-professional interface/expansion for the Color Computer. A longer card has also been announced.

**Minuses:** None noted.

**Documentation:** One page listing part numbers of Radio Shack connectors and accessories compatible with the board, plus construction and maintenance hints.

**Skill level required:** It should be stressed that this product must *not* be used in the expansion port of the Color Computer unless the user is fully aware of computer interfacing techniques, and that damage caused by improper use of the product could void any existing warranty. Users with the proper experience still must exercise proper care to avoid damage to the computer.

**Reviewer:** Ralph Tenny

**Product Name:** **Snooper Troops — The Granite Point Ghost and the Disappearing Dolphin**

**Equip. req'd:** Apple II with Applesoft or Apple II Plus with 48K RAM, DOS 3.3

**Price:** \$44.95

**Manufacturer:** Spinnaker Software  
215 First St.  
Cambridge, MA 02142

**Author:** Tom Snyder

**Copy Protection:** Yes

**Description:** *Snooper Troops* is a child's educational program designed to look like a game while teaching how to think logically. It also develops skills in note taking, map drawing, and information classification. The object of the program is to discover the who, what, where, and when, using appropriate detective skills.

**Pluses:** *Snooper Troops* is well written and challenging. It will keep a child occupied for weeks attempting to track down all the clues. Additional copies (you receive two) are available for \$2.00 from the company.

**Minuses:** The graphics are interesting for about five minutes. Each house you travel to looks identical, leading to loss of excitement. The program incorporates some lengthy delays that I find annoying.

**Documentation:** Well written, informative guide with spaces for note taking.

**Skill level required:** While the company recommends ages ten to adult, I think most adults would be bored after an hour or so. I recommend 8 to 12.

**Reviewer:** Phil Daley

## Software Catalog

### Classroom Help

**Computerized Gradebook** for the Apple assists the classroom teacher in storing, retrieving, and computing grades in a systematic manner. The program will store fifty student names, with up to ten scores per student. It will translate raw scores into standard scores, weight scores by percentage, compute total weighted scores, and assign letter grades.

The \$49.95 price includes one diskette and user instructions. Available from Electronic Courseware Systems, Inc., P.O. Box 2374, Station A, Champaign, IL 61820; (217) 359-7099.

### CoCo Screen Enhancer

The **64K Screen Expander** allows the 64K Color Computer to have a 51 x 24 upper- and lower-case display. This includes BASIC and all assembly language programs that use text displays. A character editor lets you change any of the characters.

Price is \$24.95 for cassette and \$29.95 for disk (plus \$2 shipping and handling). Available from COMPUTERWARE dealers or directly from COMPUTERWARE, Box 668, 4403 Manchester Ave., Suite 103, Encinitas, CA 92024; (619) 436-3512.

### Making Math Fun

The VIC-20 **MicRo Math Blaster** is a combination of arcade game excitement and basic mathematic drill in addition, subtraction, multiplication and

division. Color graphics and sound combine to motivate the child to practice these skills. Levels of difficulty range from grades 1-8.

Price is \$15.95. Available from M-R Information Systems, Inc., P.O. Box 73, Wayne, NJ 07470.

### VIC-20 Space Game

**Martian Raider** will have you streaking through deep space as you guide your intergalactic battle ships in an attack on Mars. You skim perilously close to the surface of the planet, devastate Martian cities and destroy ammunition dumps, while warding off ground-to-air missiles, U.F.O.'s, and meteorites. Martian Raider requires an unexpanded VIC-20 and cassette player; keyboard or joystick controlled.

Price is \$19.95. Available from your computer dealer or Broderbund Software, Inc., 1938 Fourth Street, San Rafael, CA 94901; (415) 456-6424.

### Spelling Check

**Sensible Speller**, spelling verification program for the Apple, is now available in a formatable version. This makes it possible for the individual with more than one type of word processor to utilize the same speller regardless of the type of file the word processor generates. Sensible Speller still features the complete Concise Edition of The Random House Dictionary on disk and hardcover book, over 80,000 words in all. The new Speller works with DOS

3.3, DOS 3.2, CP/M, Pascal, Word Handler, and Super Text.

Sensible Speller requires an Apple II/Apple II+ with 48K, DOS 3.3, and one or two disk drives. Two disk drives are required to delete or add words to the dictionary.

Price is \$125.00. Available from Sensible Software, 6619 Perham Drive, W. Bloomfield, MI 48033; (313) 399-8877.

### 3-D Astronomy

**Celestial Simulator** provides 3-dimensional educational Science software for the Apple. Programs show moving 3-D simulations of the planets revolving around the earth as the earth revolves around the sun from different positions in the universe. Watch a 3-D simulation of a solar and lunar eclipse. See the moon's shadow follow its movement on the earth.

Observe the stars revolving at night. Have the stars plot their paths. Give any planet's orbit an eccentricity and watch it revolve around a star while plotting its path. Take a simulated flight to Alpha Centauri — control your acceleration, speed, weight. Try not to crash into Alpha Centauri when you reach it. Compare time using Einstein's theory of relativity.

Your imagination can run wild making solar systems change and causing rockets to blast off or planets to crash or freeze.

Celestial Simulator runs on a 48K Apple II/II+ w/Applesoft in ROM or a Language Card and DOS

3.3. Price is \$99.95. Available from Soft Images, 200 Route 17, Mahwah, NJ 07430; (201) 529-1440.

### Auto Racing on the CoCo

**Revolution** for the Radio Shack Color Computer and the TDP-100 uses a series of conversational screens and menus to simulate the experience of being a race driver. Discussions with the team, choosing cars and tracks to race on, and receiving information on lap times and lap records are all part of the game.

Revolution is menu-driven and uses single-key entry wherever possible. 32K disk price is \$24.95; cassette price is \$22.95. Contact Inter + Action, 113 Ward St., New Haven, CT 06519; (203) 562-5748.

### Adventure Game

**ZORK III**, a prose adventure game, takes players into a great underground empire where they encounter the Dungeon Master, who holds their fate in the balance. The game has a subterranean fantasy theme. Zork III can be used with Apple, Atari, IBM, Radio Shack TRS-80, Commodore, NEC, Osborne, CP/M, and DEC computers.

Price is \$39.95 [NEC-APC, CP/M, PDP11 Models \$49.95]. Available from Infocom, Inc., 55 Wheeler St., Cambridge, MA 02138; (617) 492-1031.

### Electronic Spreadsheet

**NOVACALC**, a full-featured spreadsheet/financial planner, has all the

(Continued on next page)



standard spreadsheet functions like math, trig, log, sum, and average functions along with screen controls. Its advanced features include functions for depreciation (DEP), net present value (NPV), rates of return (IRR), true consolidation or roll-up (RUP) for three-dimensional spreadsheet operations. NOVACALC also features decimal and comma format control, selective column printing, wide carriage printing, helping menu and help screen, underlining, protected data fields and sharing of data among worksheets to avoid data re-entry.

NOVACALC is available for the Apple (with Z-80 card), Cromemco, IBM-PC, Kaypro, Northstar, Osborne (D.D.), Televideo, Vector, Xerox and 8" CMP. Price is **\$24.95**. For more information contact Hourglass Systems, P.O. Box 312, Glen Ellyn, IL 60137; (312) 690-1855.

**Data Base Management**

**Version 2.0 of FILE-FAX Data Base Management System** is designed as a filing system for the business-

man who wants a program that is simple to learn and easy to operate. FILE-FAX offers quick access to files and records, as well as an easy-to-use report generator, according to TMQ Software, manufacturer.

Among its applications are inventory control, customer files, mailing lists, purchase records, patient billing, and salesmen territory files.

FILE-FAX will run on Apple II, Apple II+ and IIe computers (**\$149.00**), as well as the Atari 800 (**\$129.00**). For more information contact TMQ SOFTWARE, INC., 82 Fox Hill Drive, Buffalo Grove, IL 60090; (312) 520-4440.

**Apple Word Processor**

**Screenwriter II** for the Apple II/II+ offers global search and replace, proportional spacing, insert and delete and text move, true upper- and lower-case text on your screen, 70-column display on screen, and text spooling. Requires 48K.

The **\$129.95** price includes two master disks, documentation, and reference cards. Available from Sierra On-Line Inc., Sierra On-Line Building, Coar-

sigold, CA 93614; (209) 683-6858.

**Apple Software for Bank Security Officers**

Two new software packages — **Loss Control** and **Audit Control**, are designed to reduce the costly, time-consuming, and error-prone manual procedures required by bank security officers and auditing personnel.

Loss Control package allows security personnel to track and analyze bank losses and recoveries by operating unit and category. Users can inquire into loss history using up to 13 different search criteria. They can also compare selected categories of current operating losses with prior months and years to spot problem trends and take corrective action.

Audit Control streamlines the production of audit reports and ensures accurate reporting and analysis of findings. The package combines the separate audit functions of data entry, reporting, and follow-up into one procedure through the use of the Audit Control "Turn-around" report. Descrip-

tions of standard findings, as well as often-used text, can be saved and then called up repeatedly as required.

Audit Control, priced at **\$750**, is available for the Apple II, Apple III, and IBM PC. Loss Control, also **\$750**, is available for the Apple II. Both packages require a minimum of 64K bytes of RAM and dual floppy disks. The packages include program diskettes, initial data diskettes, a self-teaching demo, and a user manual.

Available from Quest Designs, Inc., 371 22nd Street, Oakland, CA 94612; (415) 839-1579.

**Graph Program**

**Sidebar** for the VIC-20 enables you to construct, edit, and store on tape titled bargraphs. you can quickly review a series of graphs stored on tape, plus edit and re-store them.

Price is **\$9.60**. Available from MFJ Electro-Enterprises, P.O. Box 13076, Kanata, Ont. K2K 1X3 Canada; (613) 592-2962.



A/D 12-Bit, 16 Channel **\$450.00**  
AD - 121602

- Simple Software Selection of Channels
- Range ±10, ±5, ±2.5, +5, +10
- High-Speed 25 µ Sec. Conversion
- Full Software Support — Disk or Prom
- Adjustable Bipolar Reference

**Powerful — Economical — Professional**

Peripherals for your Apple II\*



Ultra Rom Board/Editor **\$190.00** APB - 102

- Powerful G.P.L.E. (Global Program Line Editor) built in
- Includes: Search and Replace — Insert and Delete — and much more
- Edit programs 2 to 5 times faster
- 32K of Bank Switchable ROM Space
- Totally Transparent — Remove or Reload with a few keystrokes — without disk!
- Extensive Macro Table eliminates multiple keystrokes for common operations
- Useful Ampersand [&] Utilities all in one place
- Applesoft\* Extensions including "IF, THEN, ELSE"
- Support for other HOLLYWOOD HARDWARE Products in Rom

Circle No. 69

6842 Valjean Avenue, Van Nuys, California 91406 (213) 989-1204

\*Trademarks of Apple Computer Inc.

# WE TOOK A BIG BYTE OUT OF COMPUTER PRICING!

**ORDERING INFO**  
We accept Visa, Mastercard, Money Orders or Certified Check. Personal checks require 2 weeks for bank clearance. All items factory fresh & carry manufacturer's warranty. Prices subject to change without notice.

## SPECIALS OF THE MONTH

**OKIDATA 82A**  
**\$419.**

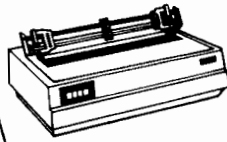

**COMMODORE 64**  
**\$ CALL**



**ATARI 800**  
**\$ NEW LOWER PRICE!**



### COMPUTERS

ATARI 400.....	\$197.
ATARI 800.....	\$598.
ATARI 410.....	\$74.
ATARI 810.....	\$439.
COMMODORE 64.....	CALL
COMMODORE VIC 20.....	\$149.
COMMODORE VIC 1530.....	\$69.
NEC PC 8001A.....	\$739.
NEC PC 8012A.....	\$499.
NEC PC 8031A.....	\$739.
SANYO MCB 1000.....	\$1599.
TIMEX 1000.....	\$84.
XEROX 5 1/4".....	CALL
XEROX 8".....	CALL
XEROX 630.....	CALL

### DISKETTES

BASF.....	CALL
MAXELL.....	CALL

### TERMINALS

TELEVIDEO 910.....	\$589.
TELEVIDEO 950.....	\$945.

### PRINTERS

DIABLO 620.....	\$1199.
DIABLO 630.....	\$1675.
OKIDATA 82A.....	\$419.
OKIDATA 83A.....	\$699.
OKIDATA 84P.....	\$1029.
EPSON.....	CALL
NEC 8023.....	\$479.

### SOFTWARE

MICROSOFT.....	CALL
MICROPRO.....	CALL
ALL MAJOR BRANDS.....	CALL

## COMPUWAY, INC.

24 LUMBER ROAD  
ROSLYN, N.Y. 11576

toll free **800 645 1362**  
**516 621 1362**

Circle No. 70

## BUY! SELL! TRADE!

COMPUTER & HAM EQUIPMENT

**COMPUTER®**  
**TRADER**

**ANNUAL  
SUBSCRIPTION  
\$10.00**

Low Ad Rates — Mailed Monthly  
Foreign Subscriptions - \$25.00 Year  
FREE 50 Word Classified Ad with Subscription Order

**COMPUTER TRADER®**

Chet Lambert, W4WDR  
1704 Sam Drive • Birmingham, AL 35235  
(205) 854-0271

Please include your Name, Address, Call Sign or Phone Number

## OHIO COMPUTER CAMP

"GIVE YOUR CHILD A BETTER CHANCE  
IN A CHANGING WORLD!"



One of the finest computer summer camps in the nation! Now in our third season, Atari Learning Center this year will offer complete recreational, cultural and social camaraderie in conjunction with Denison University. Full motel-resort facilities (swimming, sauna, tennis, etc.) and at least 6 hours every day of hands-on computer learning.

Spacious, comfortable rooms and meals at the college dorms. PLUS....mid-course weekend break at Kings Island and the fabulous Kings Island Resort Inn!

COMPARE OUR LOWER COST FEE structure before you send your child to any other camp. Reservations accepted now for two and four week sessions June 13 through August 5. Restricted to 40 co-ed students, ages 9-18, per session.

For Free information packet call:  
614-454-6408 or 349-8448

or write to:  
Mitey Byte Corporation  
1325 Maple Ave., Zanesville, Ohio 43701

Circle No. 71

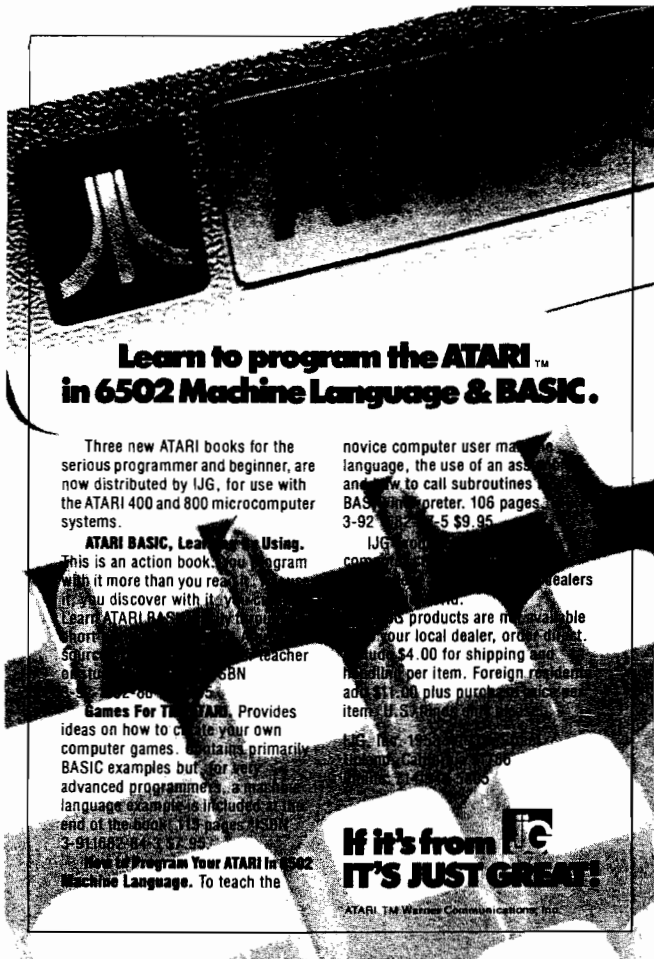

## Learn to program the ATARI™ in 6502 Machine Language & BASIC.

Three new ATARI books for the serious programmer and beginner, are now distributed by IJG, for use with the ATARI 400 and 800 microcomputer systems.

**ATARI BASIC, Learn to Use.** This is an action book. You program with it more than you read it. You discover with it why you learn ATARI BASIC. Source: IJG teacher. 3-92, 106 pages, \$9.95.

**Games For The ATARI.** Provides ideas on how to create your own computer games. Contains primarily BASIC examples but for advanced programmers, a machine language example is included at the end of the book. 3-92, 113 pages, \$9.95.

**How to Program Your ATARI in 6502 Machine Language.** To teach the novice computer user machine language, the use of an assembler to call subroutines. BASIC interpreter. 106 pages. 3-92, 106 pages, \$9.95.

IJG computer products are available from your local dealer, or direct from IJG, \$4.00 for shipping and handling per item. Foreign residents add \$11.00 plus purchase price per item. U.S. funds only please.

**If it's from IJG IT'S JUST GREAT!**

ATARI™ TM Warner Communications, Inc.

## OSI Disk Users

**Double your disk storage capacity  
Without adding disk drives**

Now you can more than double your usable floppy disk storage capacity—for a fraction of the cost of additional disk drives. Modular Systems' DiskDoubler™ is a double-density adapter that doubles the storage capacity of each disk track. The DiskDoubler plugs directly into an OSI disk interface board. No changes to hardware or software are required.

The DiskDoubler increases total disk space under OS-65U to 550K; under OS-65D to 473K for 8-inch floppies, to 163K for mini-floppies. With the DiskDoubler, each drive does the work of two. You can have more and larger programs, related files, and disk utilities on the same disk—for easier operation without constant disk changes.

Your OSI system is an investment in computing power. Get the full value from the disk hardware and software that you already own. Just write to us, and we'll send you the full story on the DiskDoubler, along with the rest of our growing family of products for OSI disk systems.

™DiskDoubler is a trademark of Modular Systems.

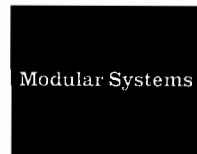

Post Office Box 16C  
Oradell, NJ 07649.0016  
Telephone 201 262.0093

Circle No. 73

# MACHINE LANGUAGE UTILITIES

## for ATARI 400/800/1200.



Vervan utility programs require no software modifications and are a must for all serious ATARI BASIC programmers.

**CASDUP 1.0 & 2.0** To copy most BOOT tapes and cassette data files. 1.0 is a file copier. 2.0 is a sector copier. Cassette only \$24.95.

**CASDIS** To transfer most BOOT tapes and cassette data files to disk. Disk only \$24.95.

**FULMAP** BASIC Utility Package. VMAP-variable cross-reference, CMAP-constant cross-reference (includes indirect address references), LMAP-line number cross-reference, FMAP-all of the above. Will list "unlistable" programs. Also works with Editor/Assembler cartridge to allow editing of string packed machine language subroutines. All outputs may be dumped to printer. Cassette or Disk \$39.95.

**DISASM** To disassemble machine language programs. Works with or without Editor/Assembler cartridge. May be used to up or down load single boot files. All output can be dumped to printer. Cassette or Disk \$24.95.

**DISDUP** For disk sector information copying. May specify single sector, range of sectors, or all. Copies may be made without read verify. Disk \$24.95.

IJG products are available at computer stores, B. Dalton Booksellers and independent dealers around the world. If IJG products are not available from your local dealer, order direct. Include \$4.00 for shipping and handling per item. Foreign residents add \$11.00 plus purchase price per item. U.S. funds only please.

IJG, Inc. 1953 W. 11th Street  
Upland, California 91786  
Phone: 714/946-5805

**If it's from IJG IT'S JUST GREAT!**

ATARI™ TM Warner Communications, Inc.

Circle No. 72

# SPECTRUM PROJECTS

### Basic Aid

"An excellent program and fine utility."  
Rainbow Review—Aug. 82  
Single control key input of BASIC commands. \$34.95

### Colorcom/E

"Out of thousands of programs, this program... SUPER!"  
80-US Review—Nov. 82  
A smart communications package. Disk or Rompack \$49.95

### Spectrum Stick

"More like arcade joysticks than anything we've yet encountered."  
Rainbow Review—Oct. 82  
Response and control put the joy back in color computing. \$39.95

### CoCo/EAD

Color Computer Editor, Assembler and Debugger  
\$6.95

### Spectrum Paddle

For quicker side-to-side action and higher scores. \$19.95

**CALL NOW**  
212-441-2807  
**FOR FAST DELIVERY**  
All orders plus \$2 shipping

**SEND TO**  
DEPT. C2 93-15 86TH DRIVE  
WOODHAVEN, N.Y. 11421  
NY residents add sales tax

Circle No. 74

# Communications Interface

## Asynchronous Interface Adapter for Printers and Communication

The requirement to get information out of a microcomputer to a printer, another microcomputer, or via the telephone to any remote system, is basic to many microcomputer systems. An industry standard, the 'RS-232', is useful in most of these applications. The RS-232 is a standard for 'serial' communication. This means that information is broken down into its lowest form — a string of ones and zeros — transmitted one bit at a time. The common type of modem is called 'asynchronous' and adheres to the RS-232 protocol. Unfortunately, this very general and useful standard does not come as part of the basic equipment of many popular systems, including the Apple II, PET and other CBM systems, AIM, SYM, or KIM, and other single board computers, and so forth. Fortunately, there is an easy way to add the RS-232 capability to your system.

The Synertek 6551 Asynchronous Communication Interface Adapter is a very intelligent chip that performs baud-rate generation, parity generation and checking, full-duplex or half-duplex operation, error detection, and more. It can be used with the Motorola 1488 and 1489 to provide a full RS-232 standard set of signals to control printers, modems, and communication between intelligent devices.

## Description of Signals Between the ACIA and the Microprocessor

CS<sub>0</sub> and CS<sub>1</sub> are Chip Selects generated by the microprocessor circuitry to select the ACIA 6551.

Reset is the master system Reset, which establishes initial conditions within the ACIA 6551.

RS<sub>0</sub> and RS<sub>1</sub> are Register Selects, normally address lines A<sub>0</sub> and A<sub>1</sub>, and are used to select the four internal addresses of the ACIA 6551.

DB<sub>0</sub> through DB<sub>7</sub> are Data Bus lines used to transfer data between the microprocessor and the ACIA.

IRQ is the system Interrupt ReQuest.

Phase 2 is the system clock.

Read/Write is the system data direction signal.

## Between the ACIA and the External World

RxC is a Receive Clock, which can be used to generate or receive external clocking for the receiver portion of the ACIA.

XTAL<sub>1</sub> and XTAL<sub>2</sub> normally connect to a 1.8432 megahertz crystal to provide the baud-rate generation.

RTS (Ready To Send) is an output pin used to control the Ready To Send pin of the modem or other device.

CTS (Clear To Send) is an input pin used to detect when the modem or other device is ready to have data transmitted to it.

TxD is the output line used to send data from the Transmit Register of the ACIA serially (one bit at a time) to the modem.

DTR (Data Terminal Ready) is an output pin that indicates to the modem when the ACIA is enabled.

DCD (Data Carrier Detect) is an input pin that indicates to the ACIA when the modem has a carrier signal.

DSR (Data Set Ready) is an input pin that indicates the status of the modem.

### Pin Configuration

GND	1	28	Read/Write
CS <sub>0</sub>	2	27	Phase 2
CS <sub>1</sub>	3	26	IRQ
Reset	4	25	Data Bit 7
RxC	5	24	Data Bit 6
XTAL <sub>1</sub>	6	23	Data Bit 5
XTAL <sub>2</sub>	7	22	Data Bit 4
RTS	8	21	Data Bit 3
CTS	9	20	Data Bit 2
TxD	10	19	Data Bit 1
DTR	11	18	Data Bit 0
RxD	12	17	DSR
RS <sub>0</sub>	13	16	DCD
RS <sub>1</sub>	14	15	Vcc

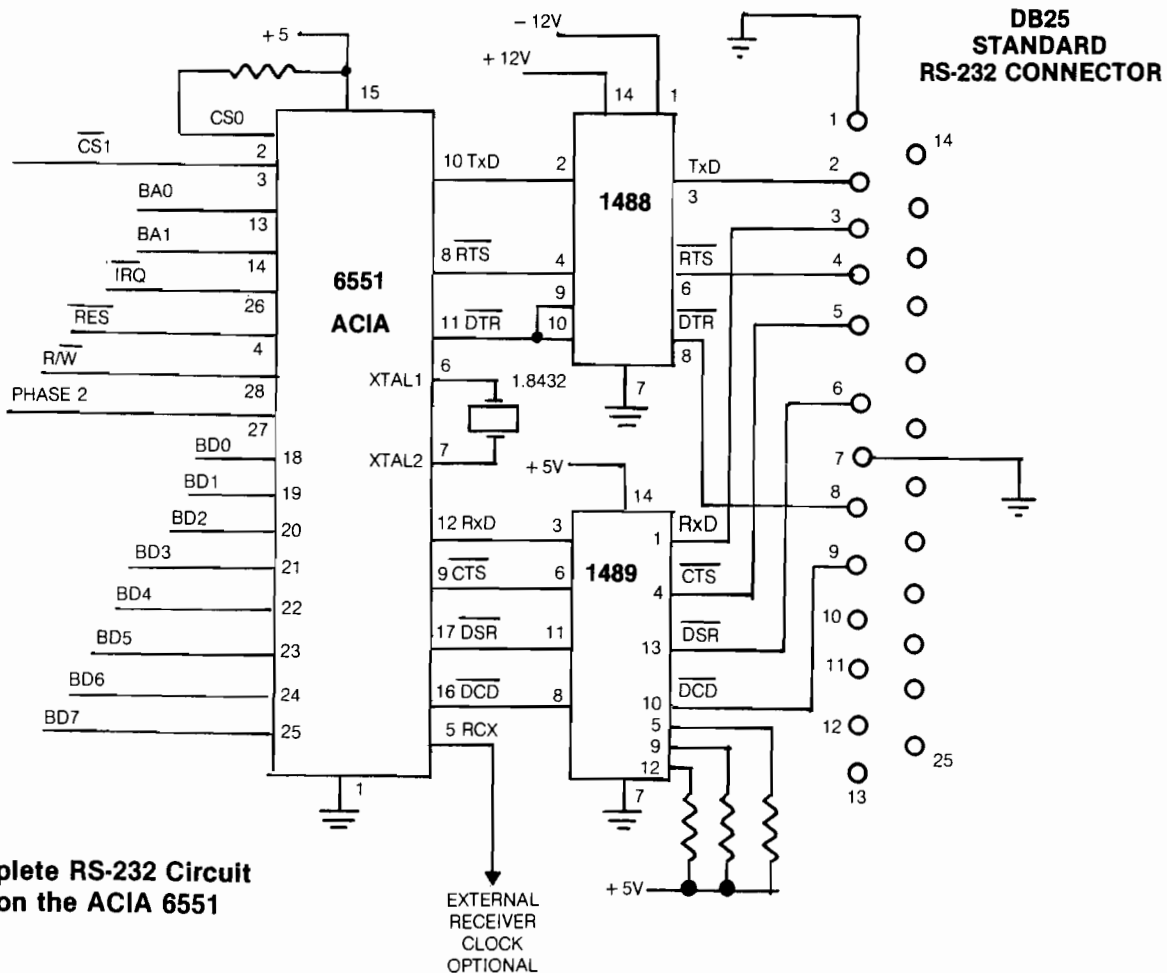

A Complete RS-232 Circuit Based on the ACIA 6551

# Communications Interface

## A Complete RS-232 Circuit Based on the ACIA 6551

The RS-232 standard permits a wide range of values to represent the high and low signals. The ACIA 6551 provides only TTL-level signals. This may be adequate for specialized applications such as talking to a printer, but many modems and some printers require the higher voltage levels, ranging up to about  $\pm 12$  volts. The ACIA and crystal provide all that is required for a TTL-level system. The 1488/1489 devices provide buffering and signal levels required to meet the complete RS-232 specification. This may be required for many standard modems. It does not add much complexity or expense to the basic circuit.

## ACIA 6551 Registers

Data Register — Register 0

Write to Register 0 will transmit data.

Read from Register 0 will receive data.

### Status Register — Register 1

Bit	Hex	Function
0	01	1 — Parity Error on Receive
1	02	2 — Framing Error on Receive
2	04	4 — Overrun Error on Receive
3	08	8 — Receive Data Register Full
4	10	10 — Transmit Data Register Empty
5	20	20 — Not Data Carrier Detect
6	40	40 — Not Data Set Ready
7	80	80 — Interrupt Request

### Command Register — Register 2

Bit	Hex	Function
0	01	0 — Disable Receiver and Interrupts 1 — Enable Receiver and Interrupts
1	02	0 — IRQ Enabled from Receiver Data Full IRQ Disabled
2	04	00 — Xmit Int. Disabled / RTS High / Xmit Off
3	08	04 — Xmit Int. Enabled / RTS Low / Xmit On 08 — Xmit Int. Disabled / RTS Low / Xmit On 0C — Xmit Int. Disabled / RTS Low / Xmit BRK
4	10	0 — Normal — No Echo 1 — Echo (Bits 2,3 must be 0)
5	20	00 — Parity Disabled
6	40	20 — Odd Parity
7	80	60 — Even Parity A0 — Mark Parity Xmit, Recv. Parity Off E0 — Space Parity Xmit, Recv. Parity Off

### Control Register — Register 3

Bit	Hex	Function
0	01	Baud Rate: 00 — 16 times External Clock
1	02	01 — 50 Baud, 02 — 75 Baud, 03 — 110 Baud, 04 — 135 Baud
2	04	05 — 150, 06 — 300, 07 — 600, 08 — 1200 Baud
3	08	09 — 1800, 0A — 2400, 0B — 3600, 0C — 4800 Baud 0D — 7200, 0E — 9600, 0F — 19,200 Baud
4	10	00 — External Receiver Clock 10 — Baud-Rate Generator (Normal)
5	20	00 — Data Word Length 8 Bits
6	40	20 — Data Word Length 7 Bits 40 — Data Word Length 6 Bits 60 — Data Word Length 5 Bits
7	80	00 — 1 Stop Bit 80 — 2 Stop Bits (1 if Word Length is 8 bits plus Parity)

### \* ACIA SUBROUTINES ROUTINES

```

*
ADATA EQU $E180 USE YOUR EQUATES FOR
ASTAT EQU $E181 YOUR ACIA REGISTERS
ACMD EQU $E182
ACTRL EQU $E183
CHAR EQU $2000 ONE RAM LOCATION
    
```

### \* INITIALIZE ACIA

```

AINIT LDA $00 CLEAR STATUS
      STA ASTAT
      LDA $0B ACIA PARAMETERS
      STA ACMD
      LDA $16 FOR 300 BAUD, 18 FOR 1200 BAUD ...
      STA ACTRL
      LDA ADATA READ OLD DATA TO START
      RTS
    
```

### \* TRANSMIT ONE CHARACTER

```

XMIT STA CHAR SAVE CHARACTER
     LDA ASTAT ANY ERRORS ?
     AND $60 DCD OR DSR ERRORS ?
     BNE ERRORS YES, SO SERVICE ERROR
     LDA ASTAT NO. READY TO SEND ?
     AND $10 TRANSMIT READY BIT
     BEQ NODATA NOT READY UNLESS BIT SET
     LDA CHAR RESTORE CHARACTER
     STA ADATA OUTPUT CHARACTER
     CLC CLEAR CARRY FOR GOOD TRANSMISSION
     RTS
    
```

### \* RECEIVE ONE CHARACTER

```

RCVR LDA ASTAT FIRST CHECK FOR ERRORS
     AND $67 ANY ERROR
     BNE ERROR YES
     LDA ASTAT DATA READY ?
     AND $08 RECEIVED DATA BIT
     BEQ NODATA BIT SET IF DATA RECEIVED
     LDA ADATA DATA AND NO ERROR
     CLC CARRY CLEAR FOR DATA
     RTS
    
```

### \* SERVICE ERRORS AND NO DATA/NOT READY

```

ERROR PHA SAVE ERRORS
      LDA ADATA READ TO CLEAR ERRORS
      PLA RESTORE ERRORS INFORMATION
      CMP $00 SET NOT EQUAL FOR ERROR
NODATA SEC SET CARRY FOR NO DATA
      RTS RETURN WITH ERROR CODE IN A
    
```

### \* SIMPLE PROGRAM TO USE THE SUBROUTINES

```

*
      JSR AINIT INIT ACIA
      .
      .
      LDA CHR,X LOAD CHARACTER TO OUTPUT
      OUT JSR XMIT OUTPUT VIA ACIA
          BCC XMOK TRANSMISSION OKAY IF CARRY CLEAR
          BNE XERROR ERROR IF CARRY SET AND NOT EQUAL
          BEQ OUT NOT READY IF CARRY SET AND EQUAL
          CONTINUE
      XMOK .
          .
      IN JSR RCVR INPUT VIA ACIA
          BCC RCOK DATA RECEIVED IFCARRY CLEAR
          BNE XERROR ERROR IF CARRY SET AND NOT EQUAL
          BEQ IN NO DATA IF CARRY SET AND EQUAL
          CONTINUE WITH CHARACTER IN A
      RCOK .
          .
      XERROR BRK BREAK OR ADD ERROR PROCESSING HERE
          .
    
```

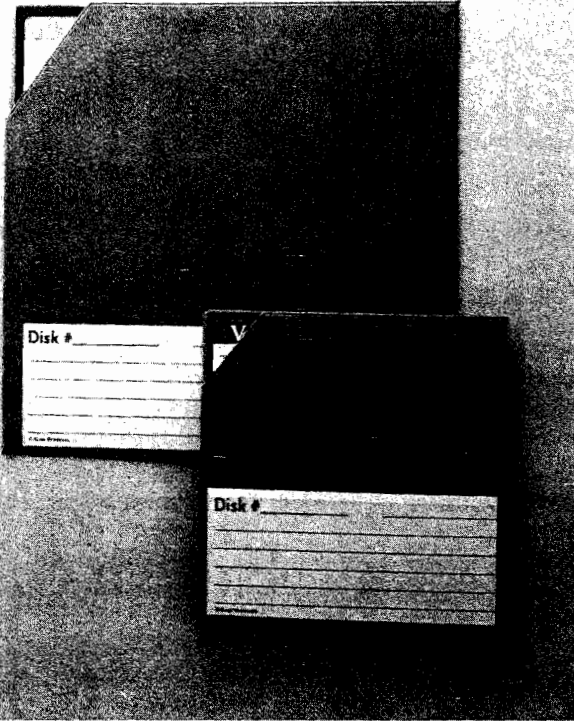

### Disk Shield

**Info-Guard** is a magnetically shielded enclosure that provides protection for disk transportation and storage. It protects flexible disks from distortion, erasure, or degradation of valuable recorded data.

Two models accommodate 8" flexible disks (\$14.50) and 5¼" flexible disks (\$9.50).

Available from C-Line Products, Inc., P.O. Box 1278, 1530 E. Birchwood, Des Plaines, IL 60018.



*Kraft Joystick from Kraft Systems Company.*

### Joystick

The **Kraft joystick** is engineered for high performance and durability, according to the manufacturer. A responsive stick mechanism with spring return provides accurate fingertip control. Cursor positioning is determined by fast-action internal switches. This plug-in unit is designed to reduce hand and finger fatigue. An eight-foot cord is included.

The joystick is compatible with Atari VCS, Atari 400/800, Commodore VIC-20, Commodore 64, and Sears Video Arcade.

Price is \$16.95. Available from Kraft Systems Company, 450 W. California Ave., Vista, CA 92083; (619) 724-7146.

### CMOS RAM Module Backup for AIM

Users and designers of 6502-based systems now have available a standard universal memory module to take care of their needs for low cost, low power, nonvolatile RAM memory. Golden Electronics Inc. has developed a nonvolatile CMOS memory module, **GE65-12K**, to fill a need in Rockwell's AIM/RM65 system of industrial microcomputer cards.

The GE65-12K module provides up to 12K of CMOS RAM with battery backup on a single card. This module has on-card battery backup to provide nonvolatile preservation of data for retention during power loss for such applications as data logging, monitoring, parameter storage, and program backup, according to the company.

The module is fully compatible with both Rockwell AIM and RM65 microcomputer card systems. It is RM65 bus compatible and is provided in a Eurocard version to plug into a Rockwell RM65 card cage or AIM buffer adapter.

Module uses include data preservation in data logging, nonvolatile storage of system parameters and program storage during program development. The GE65-12K, with 2K of memory, is priced at \$235.00.

For more information contact Golden Electronics Inc., 2133 Yorktown, Ann Arbor, MI 48105. (313) 663-9724.

## Hardware Catalog *(continued)*

### Low-Cost Graphic Plotter

The **Model-100 Sweet-P** personal plotter adds high-resolution, hard-copy graphics capability to Apple, IBM, and other personal or business computers. Interface is via a parallel port similar to the Centronics'. Menu-driven software permits the user to draw, on either paper or overhead transparency, colorful pie charts, bar graphs, line graphs, and technical illustrations.

Software features enable the plotter to define window limits, scale, alphanumeric character size, and character orientation. Provision is made for color fill; digitizing allows the user to scale and draw images traced from photographs, illustrations, or printed material.

The unit has an addressable plotting area of 7.5 x 118 inches, and will accept paper sized from 8½ x 11 inches up to 8½ x 120 inches. Maximum plotting speed is 6 inches per second, and step size is .004" — or 250 line segments per inch.

The Sweet-P fits into a slimline executive briefcase. The unit is furnished with computer interface, drawing media, and pens, plus a tutorial disk and manual to instruct users in operation and programming.

Price is \$795.00. Available from Enter Computer, Inc., 6867 Nancy Ridge Drive, Suite D, San Diego, CA 92121; (619) 450-0601.



*Sweet-P Personal Plotter from Enter Computer, Inc.*

### Apple Disk Drive Add-On

**Ghost Drive** permits one disk drive to do the work of two—for under \$100, according to Aristotle Inc. When the Ghost Drive circuit board is plugged into any of the Apple expansion slots, many software programs will operate on systems with a single drive.

Ghost Drive freezes the processor while the operator switches diskettes in the drive. A lighted toggle switch allows the operator to reactivate the processor. Suggested retail prices is \$79.95.

Available from Aristotle Industries, Box 21, Norwalk, CT 06853; (203) 853-6683.

### RS232 1200 Baud Bell 212 Compatible Modem

The **SSM TransModem 1200** features 110/300/1200 baud operation, half and full duplex, auto answer/auto dial, automatic speed detection, touch-tone and pulse dialing, and log-on and password storage. Included with the TransModem is a 6' RJ11 telephone cable that plugs directly into a telephone wall jack and power supply. The TransModem can be used with any computer having an RS232 interface.

For the Apple II Computer SSM offers two Transpak packages. The Transpaks include SSM's TransModem 1200, ASIO serial interface card, all interfacing cables, and TRANSEND 2 or 3. As an added bonus, \$220 of special subscription offers to a variety of professional services are included: The Source, America's Information Utility, Dow Jones News Retrieval Service, and Dialog Information Services.

SSM TransModem is priced at \$695. Transpak 2+ is \$999 and Transpak 3+ is \$1,100.

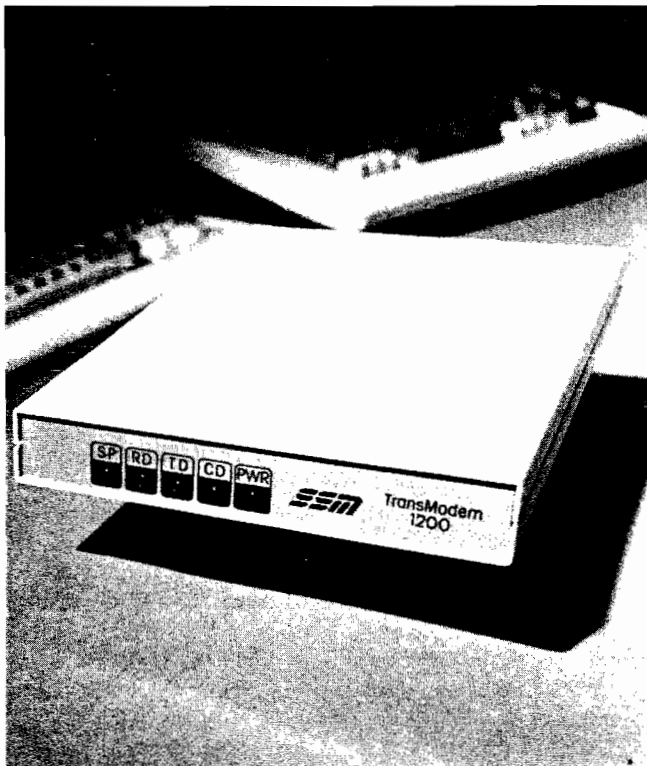

Available from SSM Microcomputer Products, Inc., 2190 Paragon Dr., San Jose, CA 95131; (408) 946-7400.



*SSM TransModem 1200*

# WE DIDN'T MAKE IT CUTE,

# WE MADE IT TOUGH!



The Grizzly™, EPD's uninterruptible power system is as tough as the animal it was named after. Like its namesake, don't let its looks deceive you. This compact system plugs directly into any standard outlet and is ready to go. All you need to do is plug what needs protection into it, flip The Grizzly on and proceed with your normal routine. In the event of a power-line problem such as a brownout

or blackout, The Grizzly will take over instantly delivering power at full load for up to twenty minutes. Simultaneously, its sonar alarm will sound signaling you to close out files and shutdown or giving you the option of allowing line power to return.

Functioning as a source of backup or simply removing submicro-second overvoltage line transients "spikes" or "glitches" from electrical circuits, The Grizzly gives you confidence in your ability to operate at peak performance and eliminate data base loss.

It's maintenance-free, warranted for one year and backed by EPD's Lloyds of London-insured guarantee. It's tough. It's The Grizzly. Available through your local dealer.



P.O. Box 673, Waltham, MA 02254  
(617) 891-6602 • 1-800-343-1813



# RAM

For ATARI  
**64K RAM BOARD FOR THE 400**  
with Lifetime Warranty

- Highest quality available
- Reduces power consumption
- Reduces heat

<b>64K Board</b>	(400)	<b>\$150</b>
<b>48K Board</b>	(400)	<b>\$115</b>
<b>32K Board</b>	(400/800)	<b>\$ 90</b>

FREE SHIPPING ANYWHERE IN U.S.A.

**INTEC**  
**PERIPHERALS**  
**CORP**

906 E. Highland Ave.  
San Bernardino, CA 92404  
**(714) 881-1533**



ATARI, 400, 800 are Trademarks of ATARI, Inc.

Circle No. 76

**Log On To The**  
**NOW!**



Join the information revolution!

**(617)423-6300**

CAN; a unique data base resource, accessed by any computer or terminal and 300 baud modem, 24 hours a day. We provide a Boston based Arts and Entertainment Guide, PBS programming, a shopping guide to computer and related products and services both local and mail order. Coming soon will be a confidential resume service. The CAN's user friendly, with word based menus, no numbers to remember, no handbooks and best of all no connect time fees.

If you would like to know more about our resume service or if you would like to reach thousands of interested viewers with your advertisement call (617) 451-0951 or write.

Long distance charges apply to callers from outside the Greater Boston Area.

**COMPUTER ADVERTISING NETWORK**  
291 Huntington Avenue Box 50 Boston Massachusetts 02115

Circle No. 77

124

# MICRO<sup>TM</sup>

## 6809 Bibliography

Dr. William R. Dial

### 129. The Rainbow 2, No. 5 (November, 1982)

Scerbo, Fred, "Now: Get a 3-D View of Space," pg. 8-10.

A TRS-80 Color Computer program to use with 3-D eyeglasses.

Inman, Don, "For More Graphics Info... Turn the Page!," pg. 12-17

A program demonstrating how the 6809-based Color Computer can animate graphics by turning the pages of memory.

Blyn, Steve, "This 'Initial' Experience Can Be Child's Play!," pg. 18.

An educational program for children using the TRS-80 Color Computer.

Delburger, R.T. and D., "Some Beautiful Patterns from 'Down Under'," pg. 23-25.

A moire program for the TRS-80 Color Computer

Hall, Chris, "Now Really Combine Your Graphics and Characters!," pg. 26-32.

A graphics utility for the 6809-based Color Computer.

Speer, Mike, "Now, Let's Hear It For the Cats Too!," pg. 32.

A short sound program for the Color Computer.

Wella, Geoff, "If You Went Sailing!...Now Try a Bit of Rowing," pg. 33-36

A graphics program for the 6809-based Color Computer.

### 130. Systems-68 Magazine, No. 3 (October, 1982)

Wood, Mike, "64 Dynamic RAM Memroy Board with Transparent Refresh," pg 9-16.

Hardware necessary to implement a hardware-refreshed 64K dynamic memory board for use with M6809 or M6800 systems.

Melear, Charles, "Vectoring by Device Using Interrupt Sync Acknowledge with the MC6809/MC6809E," pg. 28-31.

Interrupt techniques for 6809 users.

Pass, E.M., "Some Comments on 6809 Assembler Language Programming for FLEX 9, UNIFLEX, and OS-9," pg. 34-37.

A discussion of certain assembly-language programming concepts related to 6809 systems.

### 131. Compute! 4, No. 12, Issue 31 (December, 1982)

Anon., "SuperPET Upgrade Board for CBM 8032," pg. 264.

A single board upgrade is available that converts the CBM 8032 into a SuperPET.

### 132. Microcomputing 6, No. 12 (December, 1982)

Baker, Robert W., "PET-Pourri," pg. 26-28.

A few changes for the Disk Master program when it is run on a 6809-based SuperPET.

### 133. 80-U.S. Journal 5, No. 12 (December, 1982)

Goodwin, Mark D., "Color Computer Sorting," pg. 63-66.

Sort routine for the 6809-based TRS-80 Color Computer.

### 134. MICRO, No. 55 (December, 1982)

Steiner, John, "CoCo Bits," pg. 30-31.

Discussion of the TRS-80 Color Computer single disk COPY command.

Malmberg, David and Peterson, Terry M., "SuperPET Characters," pg. 97-98.

Notes on the Waterloo ASCII character set and APL for the 6809-based SuperPET.

### 135. What Micro?, No. 1 (November/December, 1982)

Staff, "Buyer's Guide to The Micros," pg. 129-159.

Specifications and relative ratings of about 150 different microcomputer systems, including nine systems based on the 6809.

MICRO<sup>TM</sup>

MICRO

No. 60 - May 1983

# FREE!

## A six-pack of tasty Apple\*\* posters!

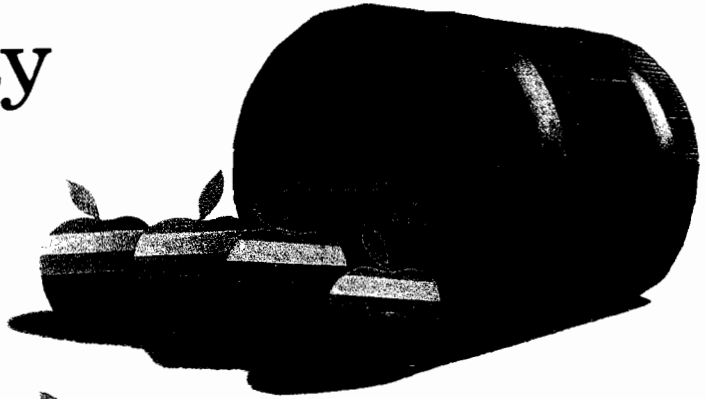

Here's your chance to get any or all of these beautiful 16 x 24 posters Free! except for just a small postage/handling charge! Commissioned by Datamost, and painted by well-known computer artist, Art Huff, each is a unique experience in design that will grace your home or office.

To get your posters, visit your favorite computer store and pick up a coupon where you see the counter display shown below. Fill out the coupon and mail it to Datamost. For each individual poster you want Free, include a registration card from any Datamost software package. Send only \$1.75 postage/handling fee with each order. (Note. Without a Datamost registration card, the Posters are available at only \$5.95 each, plus same postage/handling charge.)

Be the first to collect the entire series of these magnificent, exclusive, and FREE Apple\* posters from Datamost!



Look for this poster display at your computer store.



8943 Fullbright Ave., Chatsworth, CA 91311. (213) 709-1202  
Copyright 1983 Datamost Inc.



### YES! I Want To Participate in the Datamost FREE APPLE\* POSTER OFFER

Please sign us up and send me a complimentary set of the Six full color Apple Posters.

I would like: \_\_\_\_\_ window banners.  
\_\_\_\_\_ counter cards w/coupons.

Name: \_\_\_\_\_ Title \_\_\_\_\_

Store/Business Name \_\_\_\_\_

Address: \_\_\_\_\_

City: \_\_\_\_\_ State \_\_\_\_\_ Zip \_\_\_\_\_

Mastercard \_\_\_\_\_ Visa \_\_\_\_\_ No. \_\_\_\_\_



8943 Fullbright Ave., Chatsworth, CA 91311 (213) 709-1202

\*The posters are exclusive products of Datamost, Inc. and are not connected with, or authorized by Apple Computer, Inc.  
\*\*Apple is a trademark of Apple Computer, Inc.

# DTACK

10

## The 68000 DREAM MACHINE

### WE (SORT OF) LIED:

Motorola has been promoting its advanced microprocessor chip as a vehicle for large, complex systems **exclusively**. Now, the 68000 does work well as the heart of big, complex systems. But their promotional literature implies that one can **only** build big, complex systems with the 68000, and that is dead wrong (in our opinion). Nevertheless, the public (that's you!) perception of the 68000 follows Motorola's line: **Big systems. Complex systems.**

Our boards are **not** complex and not necessarily big (starting at 4K). Our newsletter is subtitled "The Journal of Simple 68000 Systems." But since the public has become conditioned to the 68000 as a vehicle for FORTRAN, UNIX, LISP, PASCAL and SMALLTALK people naturally expect all these with our \$595 (starting price) simple attached processor. **Wrong!**

We wrote our last ad to **understate** the software we have available because we wanted to get rid of all those guys who want to run (multi-user, multi-tasking) UNIX on their Apple II and two floppy disks. Running UNIX using two 143K floppies is, well, absurd. The utilities alone require more than 5 megabytes of hard disk.

### HERE'S THE TRUTH:

We **do** have some very useful 68000 utility programs. One of these will provide, in conjunction with a suitable BASIC compiler such as PETSPEED (Pet/CBM) or TASC (Apple II), a five to twelve times speedup of your BASIC program. If you have read a serious compiler review, you will have learned that compilers cannot speed up floating point operations (especially transcendentals). Our board, and the utility software we provide, **does** speed up those operations.

Add this line in front of an Applesoft program:

```
5 PRINT CHR$(4);"BLOADUTIL4,AS$8600":CALL38383
```

That's all it takes to link our board into Applesoft (assuming you have Applesoft loaded into a 16K RAM card). Now run your program as is for faster number-crunching or compile it to add the benefit of faster "interpretation". Operation with the Pet/CBM is similar.

### 68000 SOURCE CODE:

For Apple II users only, we provide a nearly full disk of **unprotected** 68000 source code. To use it you will have to have DOS toolkit (\$75) and ASSEM68K (\$95), both available from third parties. Here's what you get:

1) 68000 source code for our Microsoft compatible floating point package, including LOG, EXP, SQR, SIN, COS, TAN, ATN along with the basic four functions. The code is set up to work either linked into BASIC or with our developmental HALGOL language. 85 sectors.

2) 68000 source code for the PROM monitor. 35 sectors.

3) 68000 source code for a very high speed interactive 3-D graphics demo. 115 sectors.

4) 68000 source code for the HALGOL threaded interpreter. Works with the 68000 floating point package. 56 sectors.

5) 6502 source code for the utilities to link into the BASIC floating point routines and utility and debug code to link into the 68000 PROM monitor. 113 sectors.

The above routines almost fill a standard Apple DOS 3.3 floppy. We provide a second disk (very nearly filled) with various utility and demonstration programs.

### SWIFTUS MAXIMUS:

Our last advertisement implied that we sold 8MHz boards to hackers and 12.5MHz boards to businesses. That was sort of true because when that ad was written the 12.5MHz 68000 was a very expensive part (list \$332 ea). Motorola has now dropped the price to \$111 and we have adjusted our prices accordingly. So now even hackers can afford a 12.5MHz 68000 board. With, we remind-you, **absolutely zero wait states**.

'Swiftus maximus'? Do you know of any other microprocessor based product that can do a 32 bit add in 0.48 microseconds?

### AN EDUCATIONAL BOARD?

If you want to learn how to program the 68000 at the assembly language level there is no better way than to have one disk full of demonstration programs and another disk full of machine readable (and user-modifiable) 68000 source code.

Those other 'educational boards' have 4MHz clock signals (even the one promoted as having a 6MHz CPU, honest!) so we'll call them **slow learners**. They do not come with any significant amount of demo or utility software. And they communicate with the host computer via RS 232, 9600 baud max. That's 1K byte/sec. Our board communicates over a parallel port with hardware AND software handshake, at 71K bytes/sec! We'll call those other boards **handicapped learners**.

Our board is definitely not for everyone. But some people find it very, very useful. Which group do you fit into?

**DIGITAL ACOUSTICS**  
1415 E. McFadden, Ste. F  
Santa Ana, CA 92705  
(714) 835-4884

# Q-card

Questionnaire Analysis Software

- Microcomputer based  
Avoid the expense of contract services -- do everything in-house on your own Apple II+ microcomputer
- Easy data entry  
Avoid time consuming keypunching. Uses respondent-marked cards entered with an Optical Mark Reader (keyboard entry also possible).
- Comprehensive data analysis  
Sort on any variable(s), tally all responses, conduct cross tabs, correlations, linear regression, frequency distributions, and more.
- Complete editing capabilities  
Weight items, derive composites, add or delete items, and more.
- Easy-to-use  
Programs are user friendly, menu driven, and interactive. No special computer expertise is required.

Call or send for more information today.

SCIENTIFIC SOFTWARE ASSOCIATES, LTD.

BOX 206 • WAUSAU, WI 54404  
TELEPHONE: (715) 845-2066

Apple II+ is a registered trademark of Apple Computer, Inc.

Circle No. 79

## —Next Month in MICRO—

Feature:

### Operating Systems

- *Apple Operating Systems*
- *OS-9, A Structured Operating System*
- *Review of the 68000 Educational Board*
- *Comments/Utilities on Color Disk BASIC*

Plus Applications and I/O Enhancements and MICRO's Learning Center!

## VIC-20 USERS: Get Serious With A PROMQUEEN

- A cartridge development system
- Comprehensive manuals
- Program from Commodore VIC-20 keyboard into built-in 4K ROM emulator
- Jumper to target ROM socket
- Test programs in circuit
- Fits EXPANSION PORT
- Includes Hexkit 1.0, a powerful 100% machine code editor / debugger utility program that makes coding for 8-bit Micros a snap.
- Built-in EPROM programmer and power supply
- Burns & runs EPROMS for the Commodore VIC-20, too

Programs 2716, 2732, 2732A, 27C16, 27C32, adaptable to 2532 & 2764

**PROMQUEEN CARTRIDGE COMPLETE ONLY \$199**



	US	Canada
Promqueen 64	\$299.00	\$399.00
8K board with 1 EPROM	\$29.95	\$39.95
16 board with 1 EPROM	\$39.95	\$49.95
8K board with 1 EPROM, C64	\$39.95	\$49.95

Send for Free Brochure

Circle No. 80

**GLOUCESTER  
COMPUTER, INC.**

Distributed in U.S. by **Arbutus Total Soft, Inc.**, 4202 Meridian, Suite 214, Bellingham, WA 98226. Phone 800-426-1253, in Washington 206-733-0404  
Distributed in Canada by **IBC/Distribution Canada**, 4047 Cambie St., Vancouver, BC V5Z 2x9. Phone 604-879-7812

# Advertiser's Index

AB Computers	37
ABC Data Products	17
Acorn Software Systems	111
Alternative Energy Products	113
Amdek	64-65
Amplify	111
Anthro-Digital Software	97
Apogee	116
Apple Tree Electronics	83
Applied Creative Technology	2
Arbutus Total Soft	128
Armadillo Software	107
Artisan	98
ARTSCI	Cover II
Boulder Logical Testing Inc.	19
Chandler Micro Systems	113
Check-Mate	7
Commander Micro Systems	14
CompuSense	10,33,60,82,83,124
CompuTech	60
Compu-Way	117
Computer Advertising Networks	124
The Computer Book Club	15
Computer Case Co.	6
The Computerist, Inc.	101
Computer Mail Order	108-109
Custom Computer Systems	55
Datamost, Inc.	125
DataSoft, Inc.	19
Design Dynamics	9
Digital Acoustics	126
D & N Micro	43
Eastern House Software	69
EPD	3,123
Execom, Inc.	114
Foxfire Systems	10
Hudson Digital Electronics	45
I J G	118
Intec Peripherals	124
Interesting Software	90
John Bell Engineering	51
Leading Edge	Cover IV

Logical Devices	114
Lyc0 Computing	11
Mercury Micro Inc.	112
Micro Data Supplies	12
Micro House	6
Micro Spec	14
Microware Distributing	36
Midnight Software	17
Midwest Micro	104
MMG	72
Modular Mining	97
Modular Systems	118
Omega International	63
Performance Micro Products	82
Perry Peripherals	100
RH Electronics	66,89
Richvale	57
Sage Computer Technology	1
Sensible Software	95
S G C	49
S J B Distributors	13
Scientific Software	128
Skyles Electric Works	110
Sorrento Valley Assoc.	22
Spectrum Projects	118
Strom Systems Inc.	86
Talbot Microsystems	112
Valpar International	19
Versa Computing	79
Victory Software	70
Vista Computing	Cover III
Winders & Geist Inc.	93
Zytrex	60

MICRO Advertising	
What's Where in the Apple	48

*MICRO INK is not responsible for claims made by its advertisers. Any complaint should be submitted directly to the advertiser. Please also send written notification to MICRO.*

## National Advertising Representatives

### West Coast:

The R.W. Walker Co., Inc.  
**Gordon Carnie**  
 2716 Ocean Park Boulevard, Suite 1010,  
 Santa Monica, California 90405 (213) 450-9001

*serving: Washington, Oregon, Idaho, Montana, Wyoming, Colorado, New Mexico, Arizona, Utah, Nevada, California, Alaska, and Hawaii (also British Columbia and Alberta, Canada)*

### Mid-West Territory:

Thomas Knorr & Associates  
**Thomas H. Knorr, Jr.**  
 33 N. Michigan Avenue, Suite 403  
 Chicago, Illinois 60601 (312) 726-2633

*serving: Ohio, Oklahoma, Arkansas, Texas, North Dakota, South Dakota, Nebraska, Kansas, Missouri, Indiana, Illinois, Iowa, Michigan, Wisconsin, and Minnesota.*

### Middle Atlantic and Southeastern States:

Dick Busch Inc.  
**Richard V. Busch**  
 6 Douglass Dr., R.D. #4,  
 Princeton, NJ 08540 (201) 329-2424

Dick Busch, Inc.  
**Eleanor M. Angone**  
 74 Brookline,  
 E. Atlantic Beach, NY 11561 (516) 432-1955

*serving: New York, Pennsylvania, New Jersey, Delaware, Maryland, West Virginia, Virginia, D.C., North Carolina, South Carolina, Louisiana, Tennessee, Mississippi, Alabama, Georgia, and Florida*

*MICRO INK is not responsible for claims made by its advertisers. Any complaint should be submitted directly to the advertiser. Please also send written notification to MICRO.*

# Vista V1200 GREAT IDEAS



15th century renaissance man, Leonardo Da Vinci contributed an inexhaustible collection of inventions and ideas to solve the world's problems. These ideas were centuries ahead of their time. The studies on this page deal with experiments in manned flight.

Like Leonardo, Vista Computer is answering many of today's complex computer storage problems. The Vista V1200 is a great solution to Apple II™ storage. Mass storage for your Apple II™ Computer has always been a problem. On one hand, there were the exotic, expensive hard disks with no cost efficient means of backup. On the other hand, the Apple floppy drive lacked the speed and storage demanded by today's professionals.

Vista's V1200 offers both at an incredibly attractive price. The removable VistaPak cartridges offer 6 Megabytes of removable storage each and can be backed up like a floppy.

Now hard disk storage and speed can be yours with the added capability of interchangeable media. The V1200 eliminates

the worries of hard disk backup with a new backup technology.

The VistaPak cartridge. The removable cartridge stores your valuable data as well as accounting record programs, catalogs, and other software and capability.

Remove the data cartridge from the VistaPak cartridge and you have a removable hard disk. The VistaPak cartridge is a VistaPak cartridge.

Contact your Vista Computer distributor for more information.

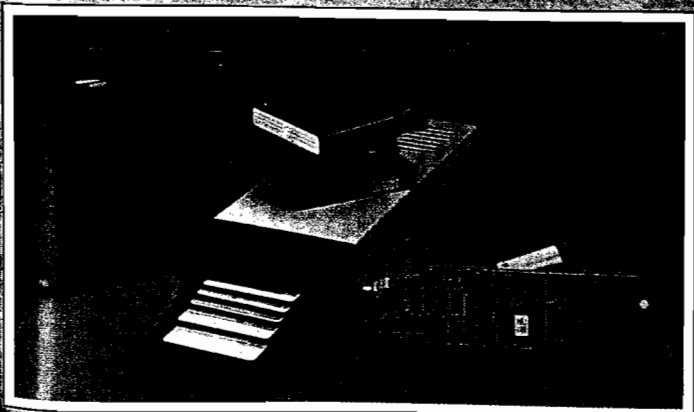

## Vista V1200

Apple II is a registered trademark of Apple Computer Co.



# GUARANTEED TOUGH.

**LEADING  
EDGE.**

225 Turnpike Street, Canton, Massachusetts 02021  
Toll-free: 1-800-343-6833; in Massachusetts (617) 828-8150. Telex 951-624.

Circle No. 83