

TANDY®

Dot Matrix Printer

DMP-105

Operation Manual

Catalog Number 26-1276

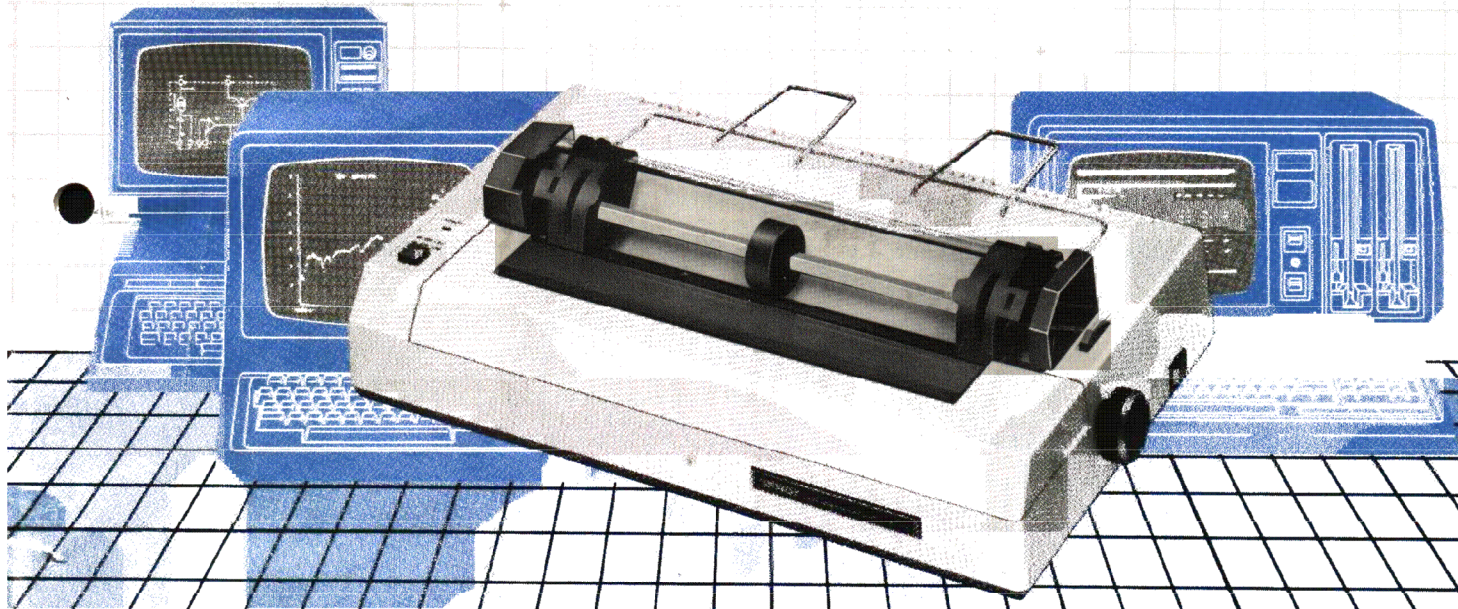

IRE / DR / DIC / HACK & DIVISION OF TANDY

ORATION

TANDY®
COMPUTER
PRODUCTS

Contents

Introduction	1
1/Description of the DMP-105	3
2/Setting Up the DMP-105	7
Paper Separator Installation	7
Tractor Installation and Removal	7
Paper Loading	9
Ribbon Installation/Replacement	12
Setting Print Function Switches (DIP Switches)	14
Connecting the DMP-105 to a Power Source	14
Carriage Movement Test	15
Self-Test	15
Connecting the DMP-105 to a Computer	16
Power-Up Sequence	16
3/Using the DMP-105 (General Printer Operation)	17
Control Codes	17
Sending Control Codes from BASIC	18
Character Printing Mode	18
Graphics Mode	18
Selecting a Print Mode	19
4/Print Font Styles and Character Widths ..	21
Selecting Font Styles	21
Standard Character Font Style	22
Graphics Characters	22
Wrap-Around	23
Elongated Characters	23
Bold Characters	24
Mixing Bold and Elongated	24
5/General Control Codes	25
Line Feed Codes (LF)	25
Special Line Feed Codes	25
Carriage Return (CR)	26
Ignored or Undefined Codes	26
DMP-105 Buffer Operation	27
6/Character Printing Mode	29
Repeat Printing	29
Underline Printing	29
Print Head Positioning	30
Printing Directions	32

7/Graphics Mode	33
Printing Graphics Patterns	34
Line Feed	36
Repeat Function	36
Print Density	37
Leaving Graphics Mode	37
Mixing Modes on the Same Line	37
Freehand Drawing	37
Appendix A/Control Code Summary	39
Appendix B/Interface	41
Parallel Interface	41
Serial Interface	44
Appendix C/Character Sets	47
94 ASCII Code	47
32 European Symbol Code	48
30 Block Graphic Code	49
Appendix D/Programming Information	51
Appendix E/Care and Maintenance	53
Printing Limits (Duty Cycle)	55
Appendix F/Schematic Diagram	57
Appendix G/Specifications	59

Introduction

Congratulations for selecting this Tandy computer product! The DMP-105 is a dot-matrix printer which can perform a variety of different printing operations. For instance, it can print:

- Normal characters (Normal, Condensed and Compressed).
- Graphics characters.

The DMP-105 operates in two modes:

- Character Printing Mode for output of program listings, report writing, or the creation of any text documentation.
- Graphics Mode for drawing pictures, figures, or graphs.

In the Character Printing Mode, the DMP-105 prints monospaced, 9x7 dot-matrix characters.

In Graphics Mode, you can use graphic data to draw just about any type of graphic configuration you desire.

You can use two types of paper with the DMP-105:

- Standard (4" —9.5" wide) computer fanfold forms with guide holes. The Printer can also print one original plus one carbon copy.
- Standard (4" —9.5") single-sheet typewriter paper.

Other software-controlled features include:

- Bidirectional minimum-distance access carriage motion.
- Full, half, and 3/4 Forward Line Feed.
- Underline capability.

and much more!

1/Description of the DMP-105

Carefully unpack the DMP-105, being sure to locate the Ribbon Cassette and the Paper Separator. Keep the empty box and packing material just in case you ever need to transport the Printer.

Be sure to remove the Yellow Band from the Carriage .

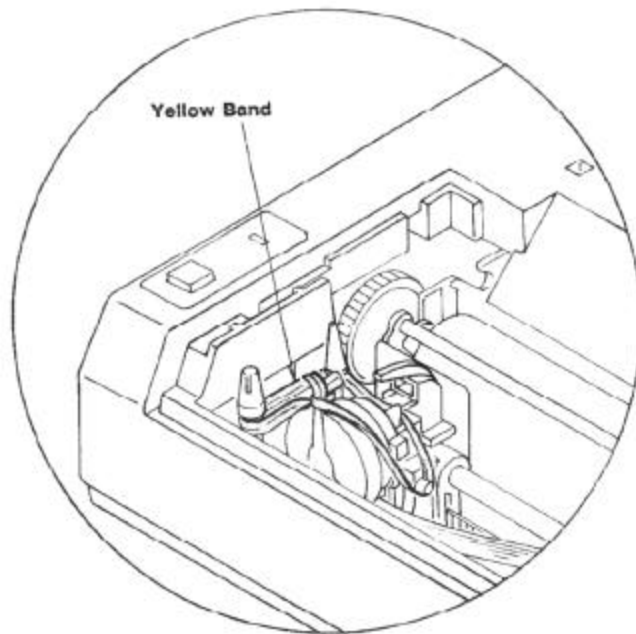

Figure 1. Removing the Yellow Band

It's important to become familiar with the DMP-105 before you set it up and begin using it.

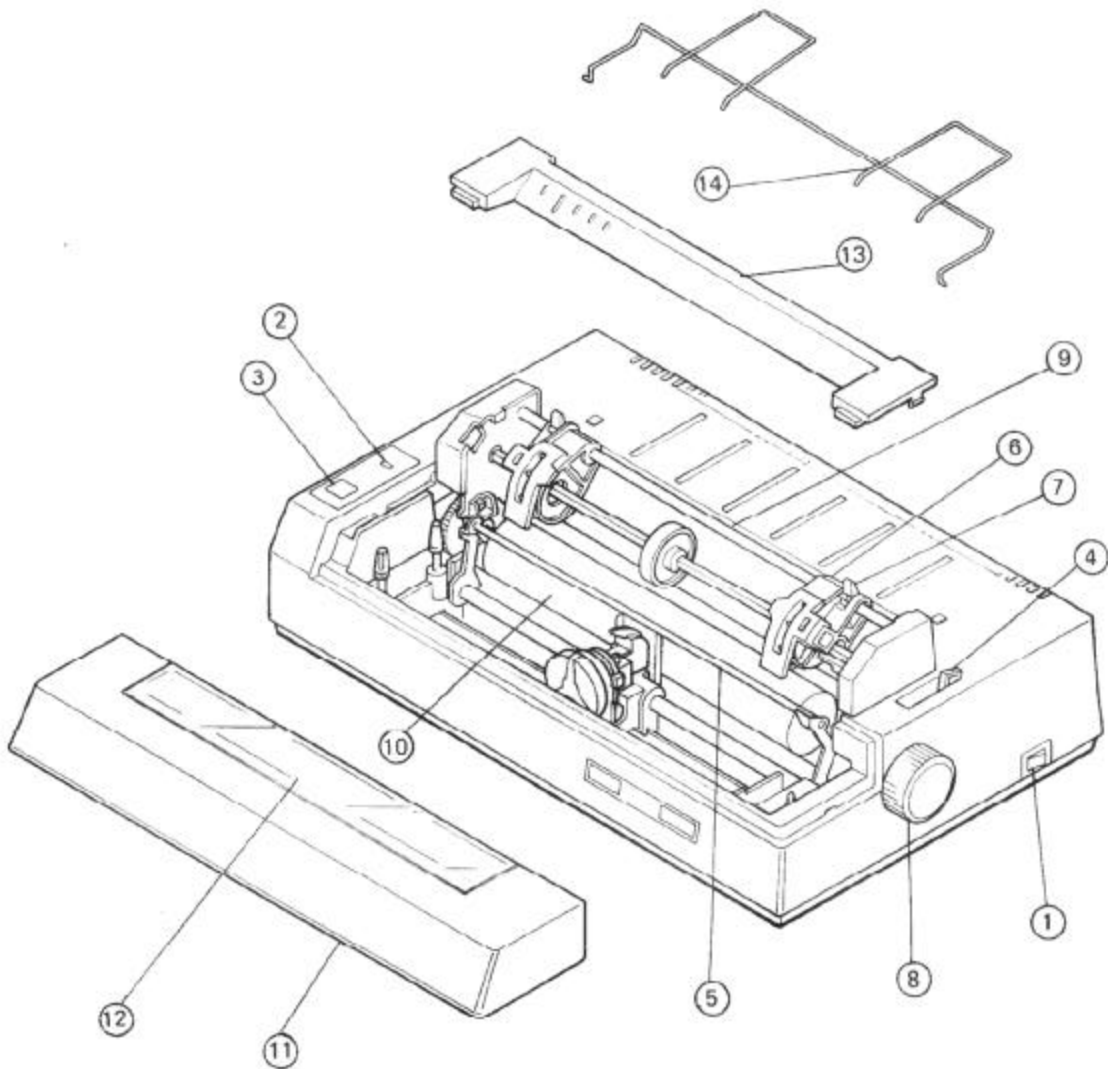

Figure 2. DMP-105 (Top View)

- ① **Power ON/OFF Switch.** Press the side of the switch marked I to turn the power ON. Press the switch the other way to turn the power OFF. Note that turning the power OFF and ON during operation may cause loss of the current program.
- ② **POWER ON Indicator.** This indicator will illuminate when the DMP-105 is properly connected and the Power ON/OFF Switch is set to ON.
- ③ **ON-LINE/OFF-LINE Switch.** When this switch is pressed in, the Printer is placed ON-LINE. When it is pressed again and released, the Printer is placed OFF-LINE.
- ④ **Platen Pressure Lever.** This lever has two positions. One is Release, for the tractor feed feature (toward the front of the Printer); the other is Friction, for the friction feed feature (toward the rear of the Printer).

- ⑤ **Paper Bail.** For optimum print quality, keep the Bail down on the paper.
- ⑥ **Tractor Feed.** This Tractor Feed is removable. See **Setting Up the DMP-105** for details on using the Tractor Feed. You can remove the Tractor when printing on single-sheet paper.
- ⑦ **Tractor Cam.** When the Cam is moved toward the rear of the Printer, the Tractor can slide from side to side, and when moved toward the front, it is locked into position.
- ⑧ **Paper Feed Knob.** Turn this knob to manually advance the paper.
- ⑨ **Paper Insertion Opening.** Be sure the paper enters the DMP-105 here.
- ⑩ **Platen.**
- ⑪ **Top Cover.**
- ⑫ **Transparent Cover.** This Cover may be opened while handling the Paper Bail.
- ⑬ **Hole Cover.** Put this Cover in place when the Tractor is removed.
- ⑭ **Paper Separator.**

Model II users: If a BASIC program stops execution because of a Printer error, typing: CONT (ENTER) will cause printing to resume. However the entire contents of the print buffer will be printed, starting with the current Print Head position.

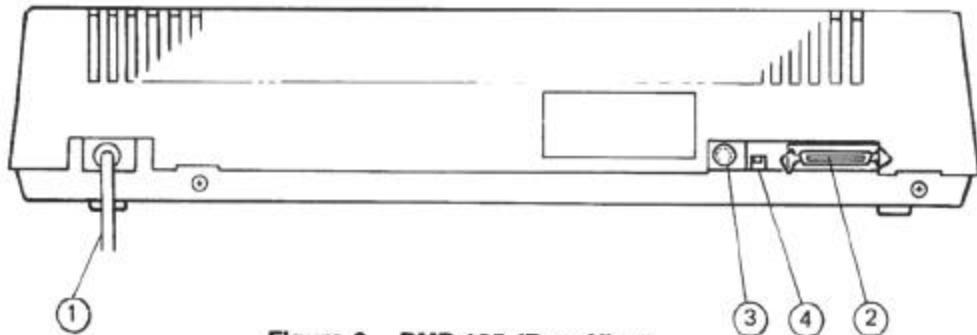

Figure 3. DMP-105 (Rear View)

- ① **Power Cord.** Plug the power cord into a wall outlet or approved power strip.
- ② **Parallel Interface Connector.** If your computer has parallel interface capabilities, connect the cable here. See **Setting Up the DMP-105** for the right cable for your computer.
- ③ **Serial Interface Connector.** If you have a Color Computer, connect the cable to the serial interface connector indicated. See **Setting Up the DMP-105** for the right cable for your Color Computer.
- ④ **Print Function (DIP) Switches.** The settings of these Switches will determine exactly how your Printer prints in any situation. Such parameters as baud rate (600 or 2400 baud) or whether you're using the serial or parallel interface must be set via these Switches.

2/Setting Up the DMP-105

The following Start-Up Checklist is a summary of how to set up your Printer. You should follow this procedure every time you start-up the Printer — **NOT JUST THE FIRST TIME.**

- Find a good spot for your Printer. Be sure to consider:
 - The Printer should be placed on a sturdy work surface.
 - The length of the printer cable will determine how far from your computer you can place the Printer.
 - Paper takes up space. Be sure to leave enough room for smooth paper flow.
 - Don't place the Printer near noise generators such as refrigerators and industrial equipment.
- Be sure the Power Switch (on the right side of the Printer) is **OFF**.
- Remove the packing materials, including the Yellow Band.
- Install continuous form fanfold paper or single-sheet paper.
- Check the Ribbon Cassette. If it has not been installed, see **Ribbon Installation/Replacement**.
- Set the Print Function (DIP) Switches (on the rear side of the Printer).
- Connect the AC power plug to a 3-wire, 120 volt, 60 Hz grounded AC outlet (220/240 V, 50 Hz where the unit is so marked).
- Check to see if the Printer is ready by running the Self-Test.
- Connect the interface cable from the computer to the printer interface connector.
- Turn the Power **ON** and check that the Power **ON** Indicator (on the Control Panel) is illuminated.
- Place the ON-LINE/OFF-LINE Switch in the **ON-LINE** position.
- Be sure that the Top Cover is closed securely.

Paper Separator Installation

Install the Paper Separator by inserting the tips of the Separator into holes provided on the top of the Printer (behind the Paper Insertion Opening).

Tractor Installation and Removal

This Printer can be used with either the Tractor Feed system or the Friction Feed system. The difference is that the Tractor Feed system is used with paper which has guide holes on both edges, while the paper used with the Friction Feed system does not have these holes.

The Friction Feed system may be used with the Tractor installed; however, better operation can be achieved if it is removed — especially when using single sheets of paper.

Removing the Tractor

1. Set the Power ON/OFF Switch to **OFF**.
2. Open the Top Cover.
3. Move the Paper Bail forward (toward the front of the Printer).
4. Hold the front bar of the Tractor in your hand and pull upward; then push it away and remove the Tractor.
5. Move the Paper Bail backward.
6. Close the Top Cover.

Installing the Tractor

1. Set the Power ON/OFF Switch to **OFF**.
2. Open the Top Cover and remove the Hole Cover.
3. Move the Paper Bail forward (toward the front of the Printer).
4. Place the pins in the Tractor onto the cutouts. Then push down on the front of the Tractor until the Tractor is securely locked into position.
5. Move the Paper Bail backward.
6. Close the Top Cover.

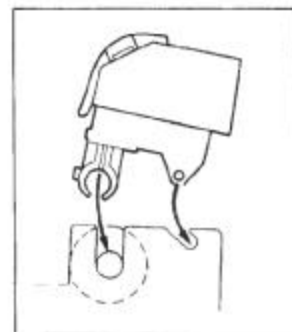
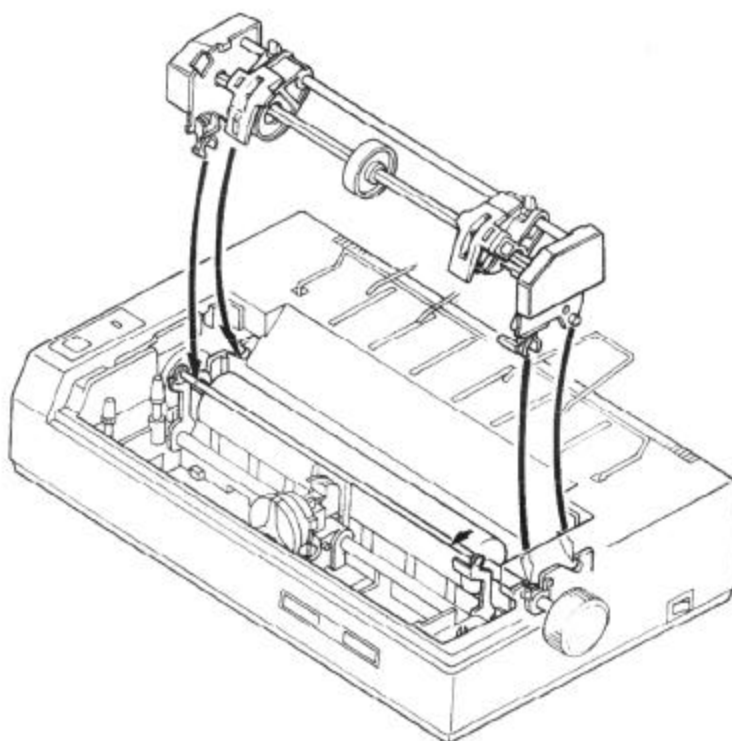
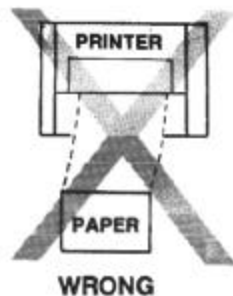

Figure 4. Installing the Tractor

Paper Loading

Warning! When loading paper (single-sheet or fanfold), be sure the paper correctly enters the Paper Insertion Opening.

It is very important that the paper enters the DMP-105 straight. The paper must be directly behind the Printer or paper skewing or jamming may occur. Proper positioning of the Paper Separator is also important to help prevent paper jamming.



If the fanfold paper is correctly loaded, it should **enter between the body of the Printer and the Paper Separator**. Once the paper is loaded and power is **ON**, press to set the **ON-LINE/OFF-LINE** Switch to **ON-LINE**. Then you may begin printing.

Single-Sheet Paper Loading

1. Be sure the Power Switch is **OFF**.
2. Remove the Tractor and set the Hole Cover in its place. (See **Tractor Installation and Removal**.)
3. Move the Platen Pressure Lever forward (toward the front of the Printer).
4. Open the Transparent Cover and tilt the Paper Bail forward.
5. Insert the paper into the Paper Insertion Opening and push the Platen Pressure Lever back toward the rear side of the Printer. Use the Paper Feed Knob to pull the paper around until it appears between the Platen and the Print Head.
6. Move the Platen Pressure Lever forward to align the paper. Push the Platen Pressure Lever back again.
7. Tilt the Paper Bail back toward the rear side of the Printer.
8. Close the Transparent Cover.

Warning! The gap between the Print Head and the Platen is mechanically adjusted properly at the factory. Do not try to adjust it. If it looks like it is out of position, contact your local Radio Shack Computer Service Center.

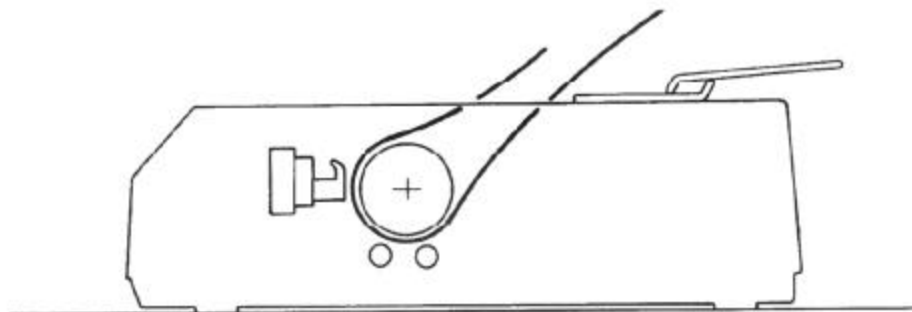

Figure 5 PWB-8 Wiring Side

Hints and Tips On Single-Sheet Paper Loading...

- With the paper properly installed, printing will continue until the paper passes the Paper Empty Sensor. The Printer will then go **OFF-LINE**. First, press to release the ON-LINE/OFF-LINE Switch to **OFF-LINE**. Next, insert another piece of paper and turn the Paper Feed Knob to advance the paper. When the paper is in place, press the ON-LINE/OFF-LINE Switch again and the DMP-105 will continue printing from where it left off, without loss of data in the print buffer.
- Remember to set the Platen Pressure Lever and the Paper Bail toward the rear of the Printer while using single-sheet paper.
- When you want to print a few more lines after the paper has passed the Paper Empty Sensor, press the ON-LINE/OFF-LINE Switch once to set it to **OFF-LINE**; then press it again to set it to **ON-LINE**. This will print one more line. Just follow this procedure once for each additional line you wish to print.

Fanfold Paper Loading

The DMP-105 will accept standard fanfold paper that is from 4" to 9.5" wide. The paper may contain one original plus one copy. Before using fanfold paper, however, the Tractor unit should be installed.

To load fanfold paper into the DMP-105:

1. Set the Power ON/OFF Switch to **OFF**.
2. Open the Transparent Cover.
3. Gently move the Platen Pressure Lever and the Paper Bail toward the front of the Printer.
4. Open the Pin Feed Paper Clamps.

5. Pass the paper between the body of the Printer and the Paper Separator. Insert the paper into the Paper Insertion Opening and push the Platen Pressure Lever back toward the rear side of the Printer. Use the Paper Feed Knob to pull the paper around until it appears between the Platen and the Print Head. Be sure the paper is straight so that the holes will line up with the pin feed sprockets. Move the Platen Pressure Lever forward to align the paper; since pin feed paper is being used, leave the Platen Pressure Lever in the forward position.

Note: If re-positioning of the Tractors is necessary, move the Tractor Cams toward the rear of the Printer so that the Tractors can slide from side to side; after adjustment, pull the Cams forward to lock the Tractors into position.

6. Close the Pin Feed Clamps to secure the paper.
7. Move the Paper Bail toward the paper.
8. Close the Transparent Cover.

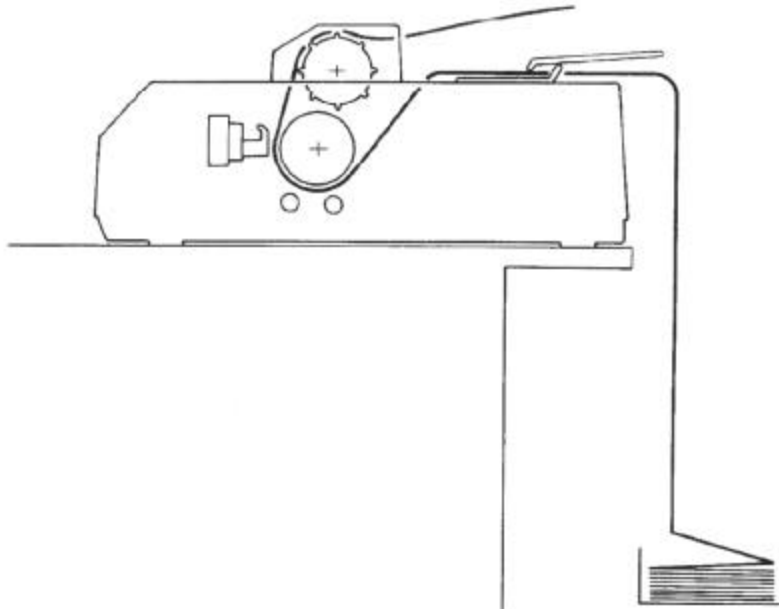

Figure 6. Fanfold Paper Loading

Warning! The gap between the Print Head and the Platen is mechanically adjusted properly at the factory. Don't try to adjust it. If it looks like it is out of position, contact your local Radio Shack Computer Service Center.

Hints and Tips on Fanfold Paper Loading...

- Remember to set the Platen Pressure Lever toward the front of the Printer and the Paper Bail toward the rear of the Printer while using fanfold paper.
- Be sure that the paper is positioned so that it can travel through the Printer without binding.
- **Do not let paper pile up** on top of unprinted paper or printed paper may be pulled back into the Paper Insertion Opening. This could jam the paper feed or damage the Printer.

Ribbon Installation/Replacement

If the Ribbon Cassette is already installed, simply check to see that it is properly threaded between the paper and Print Head.

If the Ribbon Cassette is not installed, or if it must be replaced due to excessive wear, faint printing, etc., follow this procedure:

1. Set the Power Switch to **OFF**. (**NOTE:** When you turn the power **OFF**, any information stored in the Printer's buffer will automatically be lost.)
2. Open the Top Cover.
3. Gently grasp the Ribbon Cassette and remove the Cassette by lifting it upward.

Note: Every time you replace the ribbon cassette, clean the two ribbon guide posts (located at the left end of the carriage shaft) with a soft dry cloth.

4. Unwrap the new Cassette and remove the packing foam.
5. Gently move the Print Head to the extreme right.

CAUTION: Be sure Printer power is **OFF** before manually moving the Print Head.

6. Hold the new Ribbon Cassette and pass the ribbon end around the Ribbon Guide Posts at the left of the Printer; then move the Cassette toward the right to draw out the ribbon.
7. Gently press the Cassette down until it is firmly secured by the **Stopper Claw** of the Cassette Holder.
Do not force the Cassette into place! If the Cassette is not properly fitted, the Cassette Knob will not match up with the shaft from the Cassette Holder. Do not force the Cassette down, but fit it in gradually while pushing and turning the Cassette Knob in the indicated direction.
8. Once the new Cassette is installed, move the carriage back and forth manually. The ribbon will be gradually inserted between the Ribbon Guide and Print Head.
9. Keep moving the Carriage and check that the ribbon advances properly. If the ribbon has not been properly fitted between the Ribbon Guide and Print Head (i.e., into the Print Head Ribbon Guide Bezel), the ribbon feed will not operate smoothly. (See Figure 7.)
10. Close the Top Cover.

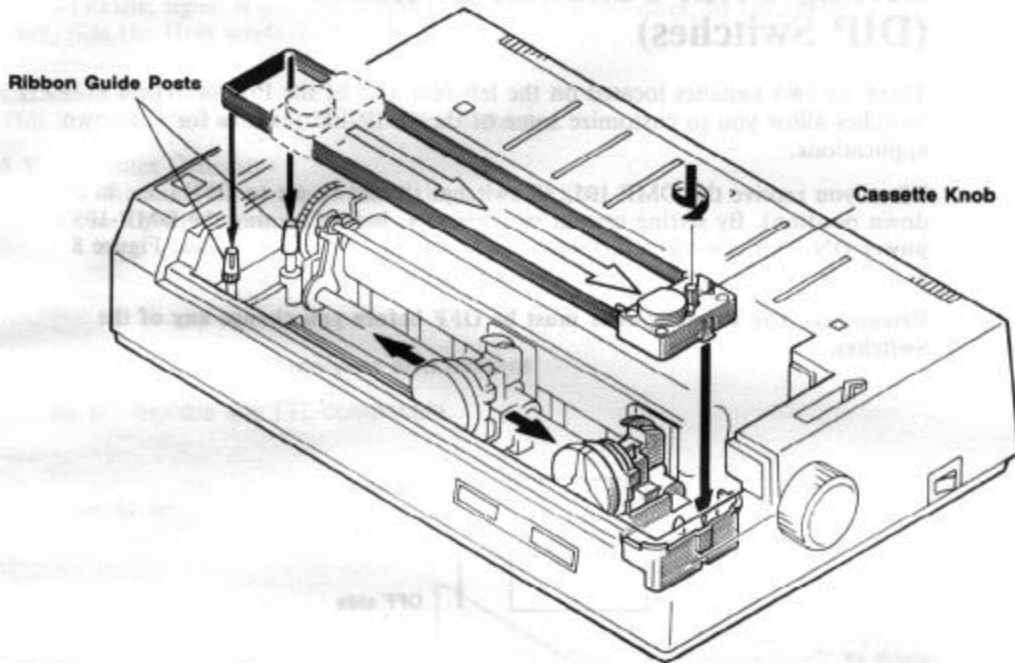

Figure 7. Ribbon Cassette Installation

Table 1. DIP Switch Settings

Pos.	Symbol	OFF	ON
1	2400 BPS	When the baud rate is 2400 BPS, transmission rate is set to 2400 BPS.	When the baud rate is 2400 BPS, transmission rate is set to 600 BPS.
2	600 BPS	When the baud rate is 600 BPS, transmission rate is set to 600 BPS.	When the baud rate is 600 BPS, transmission rate is set to 2400 BPS.

Connecting the Printer to a Power Source

When you connect the printer to an AC power source, check the following:

- Is the Power ON/OFF switch in the ON position?
- Have you checked the following items?
- Don't connect the printer to a power source until you have checked the following items.

Setting Print Function Switches (DIP Switches)

There are two switches located on the left rear side of the Printer. These Switches allow you to customize some of the DMP-105 features for your own applications.

When you receive the DMP-105, all switches should be set to **OFF** (i.e., in the down position). By setting certain switches **ON**, **before turning the DMP-105's power ON**, you can select different baud rates and interface modes. Figure 8 and Table 1 define the different switch positions and settings.

Remember! The Printer power must be OFF before you change any of the Switches.

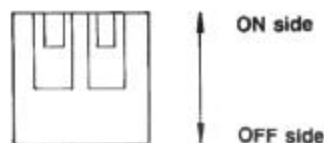

Figure 8. Print Function (DIP) Switches

Table 1. DIP Switch Settings

Pos.	Symbol	OFF	ON
1	Parallel/Serial	Parallel Interface is available.	Serial Interface is available.
2	2400 BPS/ 600 BPS	When the Serial Interface is available, transmission rate is set to 2400 BPS.	When the Serial Interface is available, transmission rate is set to 600 BPS.

Connecting the DMP-105 to a Power Source

Before plugging the power cord into an AC power outlet, check the following:

- Is the Printer Power ON/OFF Switch set to **OFF**?
- Have you removed the Yellow Band from the Carriage?
- Don't connect the Printer to your Computer yet.

Connect the AC power plug to a 3-wire, 120 volt, 60 Hz grounded AC outlet (220/240 V, 50 Hz where the unit is so marked), or to an approved power strip such as the Plug-In Power Strip (Catalog Number 61-2619) or the Automatic Power Controller, SW-301 (26-1429).

Carriage Movement Test

The Carriage Movement Test allows you to check that the Carriage moves freely from one end of the Platen to the other and that the Platen is turning properly.

Printing is not performed during the Carriage Movement Test.

You can run the Carriage Movement Test by following these steps:

1. Set the ON-LINE/OFF-LINE Switch to **OFF-LINE** and then set the Power Switch to **ON**.
2. The Carriage first moves toward the right until it strikes the Right Switch which determines the home position at the left; then it moves left until it reaches the home position.
Press the ON-LINE/OFF-LINE Switch to set it to **ON-LINE** while the Carriage is moving toward the left. The Carriage will move back and forth, performing a Line Feed at the end of each line.
3. Turn the power **OFF** to end the Carriage Movement Test.

Self-Test

The DMP-105 has a **built-in** Self-Test feature which lets you check printing quality and general printer operation before you connect the Printer to your computer. This is a good time to check that the Print Head is set properly (printing is neither too faint nor smudged) and that paper is feeding correctly. The Self-Test will last for several minutes.

Before running the Self-Test, however, always be sure to load the DMP-105 with wide paper (9.5" wide) since the Test prints from one end of the Platen to the other. **Printing on the Platen can shorten the life of the Platen and the Print Head.**

To run the Self-Test:

1. Plug the Printer into an AC power outlet.
2. Set the ON-LINE/OFF-LINE Switch to **ON-LINE**.
3. Set the Power ON/OFF Switch to **ON**.
4. Press the ON-LINE/OFF-LINE Switch to set it to **OFF-LINE** while the Carriage is moving toward the left.
The Printer will begin printing rolling ASCII 96 characters in Standard 10 CPI mode.
5. Printing will continue until you turn the power **OFF**.

Connecting the DMP-105 to a Computer

Before making any connections between the Printer and your computer, be sure all units are off!

You must also be sure you have the correct cable for your computer if the DMP-105 is to operate properly. Table 2 describes the printer cables carried by Radio Shack; Table 3 provides a quick reference for printer connection locations.

Table 2. Computer to DMP-105 Cables

COMPUTER	Cable Number
Model I (Keyboard only)	26-1411(available through National Parts)
Model I (Exp. Interface)	26-1401
Model II/16/2000/DT-1	26-4401
Model III/4	26-1401
Color Computer	26-3020
Model 100	26-1409

Table 3: Computer Connection Points

COMPUTER	Connector
Model I (Keyboard only)	Rear side of Keyboard
Model I (Exp. Interface)	Left side of E.I.
Model II/16/100/2000	Rear Panel of Computer
Model III/4/DT-1	Underneath Panel
Color Computer	Rear Panel of Computer

1. Attach the molded male end of the cable to the connector on the left rear side of the Printer.
Do not force the plug. If it doesn't fit one way, turn it over and try again.
2. Connect the other end of the cable to the Printer Jack of your Computer.
See your computer owner's manual for specific instructions.

Power-Up Sequence

The specific power-up sequence will depend upon your Computer. We suggest you consult your computer owner's manual for details on powering up your computer with peripheral devices (such as printers).

In any event, the Power Lamp will remain lit while the Printer is **ON**.

It is essential that the Printer remain **ON** when connected to the Computer. If you turn the power **ON** or **OFF**, or a Printer is connected but not turned on, erratic operation of the entire system may occur.

3/Using the DMP-105 (General Printer Operation)

The DMP-105 is designed for two distinct applications:

- Character Printing
- Graphics Printing

The Printer responds to software codes from the computer in two different ways — one for each application. The two response patterns, or modes, have many similarities, but each has its own unique features.

The **Character Printing Mode** is used for printing characters. In this mode, Line Feed commands do not cause immediate printing. Instead, they are stored in the Printer's memory along with the other data. When the current line is printed, the Line Feed commands stored in the memory determine the pitch of the paper feed.

The **Print Pitch** (character spacing) is determined by the space the DMP-105 puts between each printed character and also by the **Font Style**. Consequently, you must think of Pitch in terms of the number of characters printed per inch - 10 CPI, 12 CPI, and 16.7 CPI for Standard printing and 5 CPI, 6 CPI, and 8.3 CPI for Elongated printing.

In **Graphics Mode**, you have complete control of the **Print Head**. This mode can be used to create a custom letterhead, designs, special type fonts, etc.

However, with Graphic operation, many control codes (which can be used with Character Printing operation) cannot be used.

The DMP-105 doesn't return an error when you send such a code — it simply ignores the code. This includes codes that change line feed pitch. **Graphics Mode** uses only one Line Feed (7/72") to insure full coverage of the paper.

Control Codes

Before investigating the various print modes, consider how the computer communicates with the Printer.

All information is sent to the Printer as numbers between 0 and 255 decimal (00-FF for you hexadecimal fans). The Printer interprets these numbers according to the **American Standard Code for Information Interchange**, commonly referred to as the **ASCII** code. (See **Appendix C** for a list of ASCII codes.) Most numbers (or codes) are printed as letters, numbers, or symbols. However, the numbers 0-31, as well as some special sequences of code numbers, are used to **control** various functions of the Printer. These **Control Codes** allow you to change character sets, select print modes, underline, etc.

The Control Codes have different meanings, depending on the current print mode. If a Code is not recognized by the Printer, it is printed as **X**. The next few sections demonstrate how some of the Control Codes activate various Printer functions. Read these sections carefully.

Sending Control Codes from BASIC

Some Printer features are activated by a single code, but many functions require a sequence of two or more codes. Most multiple code sequences begin with decimal 27 (referred to as the **ESCAPE** code). The ESC code notifies the Printer that a special sequence is on its way. The next code(s) sent determines which Printer feature is selected. In BASIC, use `CHR$()` to send these codes to the Printer.

Note: This section will use the command **LPRINT** in examples that send codes to the Printer. If you're using a Tandy Color Computer, substitute **PRINT #-2,** for **LPRINT.**

For instance, set up the DMP-105 as described earlier and enter BASIC in the normal way. Then type the following program:

```
10 REM
20 LPRINT "DATA" ; CHR$(27) ; CHR$(28) ; " PROCESSING "
30 LPRINT "MODE "
```

and **RUN** it.

Roll the paper forward and look at the results. The word **MODE** printed over part of **DATA PROCESSING**. Why? The codes `CHR$(27)` and `CHR$(28)` are the guilty parties. Take a quick look at **Appendix A**. This chart shows the various code sequences understood by the DMP-105. The Control Code sequence `CHR$(27);CHR$(28)` means **change the forward line feed to half its normal distance**.

Character Printing Mode

Line Feed commands are not executed immediately. The (27 28) sequence didn't cause a Half Forward Line Feed until after the first line was printed. The set Line Feed pitch stays in effect until a new Line Feed pitch is designated.

Type: `LLIST (ENTER)`

Sure enough. You still have that short Line Feed.

Type: `LPRINT CHR$(27);CHR$(54)` to return to normal Line Feed pitch.

Graphics Mode

Graphics Mode is very different from the Character Printing Mode. For one thing, Graphics Mode accepts only one Line Feed Code — `CHR$(10)`. This Line Feed is fixed at 7/72". Furthermore, only a few of the Character Printing Mode features are available in the Graphics Mode. Standard letters and symbols, for example, are ignored by the Printer when it is in Graphics Mode. Instead, numeric data from 128 to 255 is translated into dot patterns for the Print Head. This lets you produce high-resolution graphic print-outs of charts, logos, etc.

For a quick look at this Mode in action, change our test program to:

```
10 LPRINT CHR$(18);
20 FOR I=128 TO 255
30 LPRINT CHR$(I);
40 NEXT I:LPRINT CHR$(30);
```

and **RUN** the program.

CHR\$(18) puts the DMP-105 into Graphics Mode. The numbers 128 through 255 are interpreted as dot patterns.

Type: LPRINT CHR\$(30) (ENTER) to return the Printer to CP Mode. Try LLISTing the program to be sure you're not stuck in Graphics land.

Selecting a Print Mode

Table 4 summarizes the Control Codes required to move from one mode to another.

Table 4. Control Codes for Changing Modes

If you're in:	and want to change to:	Send a CHR\$():	
		(Dec)	(Hex)
CP	Graphics	18	12
Graphics	CP	30	1E

Hints and Tips About Print Modes...

Character Printing Mode

- All commands which determine Line Feed pitch are stored in the Printer's memory. They are not executed until a LF code (10 Dec. or 138 Dec.) is received. Then, the paper advances according to the pitch codes stored in the Printer's memory.
- Line Feed commands stay in effect until replaced by a new command.
- All printable characters (except user-defined Graphics) can be printed in this mode.

Graphics Mode

- Only one Line Feed Code (10 Dec.) is acceptable. The LF Code causes the paper to move 7/72" forward. No other pitch is allowed.
- Decimal numbers 128-255 sent via CHR\$ in BASIC are interpreted as pin firing patterns for the Print Head.
- Only a few code sequences are recognized in Graphics Mode.

4/Print Font Styles and Character Widths

The DMP-105 has two distinct print (character) font styles:

- Standard
- Graphic Characters

Each font style is created with a unique dot pattern laid out in a grid or matrix.

The character styles differ in the size of the matrix and the way individual characters are created within the matrix.

The horizontal dot positions overlap; vertical ones don't.

Table 5. Character Widths and Densities

Font Style	Matrix Size	Pitch
Standard	9×7	Normal 10 CPI/Elongated 5 CPI Compressed 12 CPI/Elongated 6 CPI Condensed 16.7 CPI/Elongated 8.35 CPI
Block Graphics	6×6	Normal 10 CPI Compressed 12 CPI Condensed 16.7 CPI

Table 5 shows that there are three basic pitches.

- Normal
- Compressed
- Condensed

When character pitch is changed (for example from Normal to Condensed), the data in the buffer is printed, some dot space is added, and then printing will continue in the current line with the new character style.

Selecting Font Styles

Character styles are selected by Control Codes from your computer (i.e., via software) during operation.

Character styles stay in effect until another style is selected. Even entering Graphics Mode does not change the font. The DMP-105 returns to the last active font on leaving the Graphics Mode.

Table 6 is a summary of the Character Style change commands:

Table 6. Character Style Change Commands

Send a CHR\$(): (Dec)		: (Hex)		If You Want:
27	19	1B	13	Normal
27	23	1B	17	Compressed
27	20	1B	14	Condensed
27	14	1B	0E	Start Elongation
27	15	1B	0F	End Elongation
27	31	1B	1F	Start Bold
27	32	1B	20	End Bold

Standard Character Font Style

The Standard character set is printed in a 9×7 dot matrix (9 dots wide by 7 dots high).

Each of the Standard characters can be printed in three main character widths:

- Normal 10 Characters Per Inch (CPI)
- Compressed 12 CPI
- Condensed 16.7 CPI

Each of these widths can be elongated (double-width), which gives half as many characters per inch and a total of six different print widths.

You can get a better feel for the different available print widths by printing a few sample lines. Type in this program:

```
NEW ENTER
110 F$="STANDARD "
120 N=19: W$="NORMAL ":GOSUB 240
130 N=23: W$="ELITE ":GOSUB 240
140 N=20: W$="CONDENSED ":GOSUB 240
230 LPRINT CHR$(27);CHR$(19):STOP
240 LPRINT CHR$(27);CHR$(N);F$;"CHARACTERS ";W$;"DENSITY"
250 RETURN
```

and RUN it.

The subroutine in line 240 sends the required Control Codes to the DMP-105. Line 230 returns to Normal character width and stops program execution.

Graphics Characters

The second character set is a 6×6 dot-matrix character set used for Block Graphics printing. The characters can be Normal 10 CPI width, Compressed 12 CPI, or Condensed 16.7 CPI. This set is not fully compatible with the screen graphics of most computers; it is a unique character set.

A 6×6 dot-matrix character set is available in Normal 10 or 5 CPI, Compressed 12 or 6 CPI, and Condensed 16.7 or 8.3 CPI character conditions.

To see how the various character widths affect the Graphics characters, add:

```
190 N=19: W$="NORMAL " :F$="GRAPHIC " :LPRINT
200 GOSUB 240:GOSUB 260
210 N=23: W$="COMPRESSED " :GOSUB 240: GOSUB 260
220 N=20: W$="CONDENSED " :GOSUB 240: GOSUB 260
260 FOR I=224 TO 254:LPRINT CHR$(I);: NEXT I
270 LPRINT: RETURN
```

and RUN the program.

Since the normal line-to-line spacing is 1/6" or 12 dots high and the Graphics characters are 6 dots high, we can create continuous vertical graphics by using the Half Forward Line Feed (CHR\$(27);CHR\$(28)). Add these lines to the program:

```
10 LPRINT CHR$(27);CHR$(28);
20 FOR R=1 TO 3
30 FOR C=1 TO 7
40 READ N: LPRINT CHR$(N);
50 NEXT C: LPRINT
60 NEXT R: LPRINT CHR$(27);CHR$(28);
70 DATA 241,243,241,224,241,243,241
80 DATA 224,244,241,241,241,249,224
90 DATA 241,248,241,224,241,248,241
```

and RUN it.

When you've printed out the results, delete lines 10 through 90.

Wrap-Around

The DMP-105 is a dot-addressable Printer. Therefore, line length is not determined by the number of characters, but by the number of dots-per-line. By counting dot columns, a combination of different font styles, including standard and elongated, can be printed on each line. The numbers of addressable dots-per-line in the Character Printing Mode is:

- Normal = 960
- Compressed = 1152
- Condensed = 1600

If the length of text the Printer receives exceeds the limit of dots-per-line, a Line Feed is inserted and the last character is printed from the start of the next line. This is called **wrap-around**.

Elongated Characters

Any of the character font styles can be elongated to twice their normal width.

Table 7. Elongated Printing

Send CHR\$():		To:	
(Dec)	(Hex)		
27 14	1B 0E	Start Elongation	
27 15	1B 0F	End Elongation	

The start (27 14) and end (27 15) codes for Elongated characters may be entered any number of times within a line and can be used in every mode.

You can easily elongate the characters in the current program. Change:

```
100 LPRINT CHR$(27);CHR$(14)
230 LPRINT CHR$(27);CHR$(19);CHR$(27);CHR$(15):STOP
```

and RUN the program.

Bold Characters

Bold characters are implemented in much the same way as Elongated characters.

Table 8. Bold Printing

Send CHR\$(): (Dec)		(Hex)	To:
27	31	1B 1F	Start Bold Printing
27	32	1B 20	End Bold Printing

Bold characters start when you send a CHR\$(27);CHR\$(31) and stop when you send a CHR\$(27);CHR\$(32).

When a (27 31) code sequence is received, the DMP-105 prints the current buffer contents; then it resumes Bold character printing from the next character received.

Bold characters can be added to the current program by changing lines:

```
100 LPRINT CHR$(27);CHR$(31)
230 LPRINT CHR$(27);CHR$(19);CHR$(27);CHR$(32):STOP
```

Now RUN the program.

Mixing Bold and Elongated

Bold and Elongated characters cannot be active at the same time. The first code (either Bold or Elongated) to be received and activated will take precedence. The DMP-105 then simply ignores the second code.

5/General Control Codes

Line Feed Codes (LF)

When a LF (ASCII 10) code is received by the DMP-105, all data in the Printer buffer is printed followed by a Line Feed. Unless you tell it otherwise, the DMP-105 uses 1/6" Forward Line Feed when advancing paper.

Pitch settings are sent to the DMP-105 in a two-code sequence. First, a Control Code 27 is sent (CHR\$(27)). This tells the DMP-105 that a special code sequence will follow. The next number determines the specific pitch. These Control Codes are listed in Table 9.

Table 9. Line Feed Control Codes

Send CHR\$(): (Dec)		(Hex)	To:
27	28	1B 1C	1/2 Forward LF (1/12")
27	54	1B 36	Full Forward LF (1/6")
27	56	1B 38	3/4 Forward LF (1/8")

Hints and Tips on Line Feed.....

- In the Character Printing Mode, codes are stored in the Printer buffer. They are not activated until a LF code is sent.
- Line Feed Pitch codes have no effect in the Graphics Mode. The Line Feed is set at 7/72" forward.

Special Line Feed Codes

There are two n/72" Forward Line Feed codes that operate in different ways; one is for execution and the other is for setting.

Table 10. Special Line Feed Control Codes

Send CHR\$(): (Dec)		(Hex)	To:
27	90 n	1B 5A n	n/72" Forward Line Feed Execution
27	91 n	1B 5B n	n/72" Forward Line Feed Set

n/72" Forward Line Feed Execution:
This code is effective in both CP and Graphics Modes.

- When a CHR\$(27);CHR\$(90);CHR\$(n) is received by the DMP-105, all data in the Printer buffer is printed followed by the LF code. The Forward Line Feed pitch is determined by the value n between 0-255. For example, if n is set to 12, one full Line Feed will be carried out because one full Line Feed is 12/72" (1/6").

n/72" Forward Line Feed Set:

This code is similar to the above code except the timing to be executed. It is effective only in CP Mode.

- When a CHR\$(27);CHR\$(91);CHR\$(n) is received by the DMP-105, no Line Feed occurs but it is stored in the Printer buffer. The n/72" Forward Line Feed will be executed with the reception of the Line Feed code (LF=10 or 138). n is a value between 0-127.

Carriage Return (CR)

A CR (13 or 141) code tells the Printer to print the current buffer contents, and then performs either a Carriage Return followed by a Line Feed or a Carriage Return only, depending upon the following New Line Control Code setting.

Table 11. New Line Control Codes

Send CHR\$(): (Dec)		(Hex)		To:
27	21	1B	15	CR = CR Set
27	22	1B	16	CR = CR + LF(NL) Set

- When a CR (13 or 141) Code is received by the DMP-105 with a CHR\$(27);CHR\$(21) already received, only a Carriage Return is performed after printing the buffer.
- When a CR Code is received with a CHR\$(27);CHR\$(22) already received, a Carriage Return followed by a Line Feed (NL) is carried out.
- At power ON, the Printer is set to New Line mode.

Ignored or Undefined Codes

Codes that are unusable or undefined in a given mode are either ignored or printed with the symbol X which represents an invalid code.

There are several reasons why a code may be unusable in a certain mode. Redundant codes that don't change the current Printer status are usually ignored. For example, if the Printer is in Graphics Mode, sending a CHR\$(18) (used to enter Graphics Mode) is useless. And there are many ASCII control codes in the range 0 to 31 that the DMP-105 simply doesn't recognize. ASCII 0, for example, is not used in either print mode.

The following summarizes the undefined codes:

Table 12. DMP-105 Ignored Control Codes

Both Modes:

- Out of range on repeat sequence.
- Out of range on positioning sequence.
- Redundant codes that don't change the current printer status.
For example, if you send a CHR\$(14) when underline is already set.

CP Mode: 0, 1, 127, 255
Graphics Mode:
All codes in the range 0-127 are ignored, except (10), (13), (30), (27 14), (27 15), (27 90 n), (27 16 n1 n2) and (28 n1 n2)

Codes printed as X

CP Mode only:

- All codes from 0-31 and 128-159, except the active function codes or the above ignored codes.
- All codes between 192-223.

DMP-105 Buffer Operation

The DMP-105's ability to temporarily store data is one of its main advantages over a typewriter. Codes sent to a typewriter (i.e., keys pressed) are transferred immediately to the paper. Codes sent to a Printer are not printed immediately; they are stored in a separate section of memory in the Printer called the buffer. When the buffer fills, or certain codes are received (i.e., LF or CR), the buffer is emptied and all data is then printed on the paper. What happens after the buffer data is printed depends on the circumstances. In some cases, printing continues on the same line; in others, the Print Head is moved to a different position relative to the paper.

In the CP Mode, commands for changing print fonts, Line Feed, etc., can be stored in the buffer to take effect when the data is dumped to paper.

Understanding how the buffer works is important for those who wish to gain full control of the DMP-105.

Hints and Tips on the DMP-105 Buffer....

For CP and Graphics Modes

- The buffer allocates a fixed number of dots, depending on the character width selected. The buffer is emptied when the data stored equals that number. If different character widths have been used on the same line, the last character added may exceed the dot count. The buffer is printed without this last character.
- The Carriage Return (CR = 13 decimal) code automatically activates printing (assuming at least one character code is already in the buffer).
- The Line Feed (LF = 10) code automatically activates printing, and the Print Head is positioned at the start of the next print line.
- If the computer delays more than a second before sending the next print code, the buffer is printed. Printing continues from the current position.
- The Head Positioning sequence (27 16 n1 n2) prints the buffer. Printing continues in the current line at the dot address specified by the (27 16) command.
- When the buffer is full, the buffer is printed. Printing continues from the current position.

CP Mode only

- If a character set of different dot density is selected, the data in the buffer is printed. Codes for changing character sets are: (27 19), (27 20), and (27 23). Printing continues in the current line with the new character style after adding some dot space.
- Dot graphics printing continues from the current character position.
- When a start **Bold** or end **Bold** is received, the buffer is printed. Bold printing continues from the current character position.
- Since the buffer capacity is small, if you frequently use the Underline and/or Elongated features, the buffer may be printed before the contents exceed the capacity for one line. Printing will continue from the current character position.
- If a CR = CR feature has been selected, reception of the Carriage Return (CR = 13) code causes the buffer contents to be printed followed by a Carriage Return, and the next full buffer will overprint on the current line. If CR = CR + LF(NL) has been selected, it will cause the buffer contents to be printed followed by a New Line (CR and LF). Printing will resume at the start of the next print line.

Graphics Mode only

- When the **End Graphics Mode** command is received, the buffer is printed. The Printer returns to the CP Mode and printing continues in the same line from the current print position.

Note: Repeat data can cause a buffer full or overflow condition, as well as single characters.

6/Character Printing Mode

Repeat Printing

The DMP-105 provides a built-in repeat capability. You can use it to repeat a single character code up to 255 times. It's great for repeating graphics codes, underlining, repeated block graphics, etc. The Repeat features use a three-code sequence:

- CHR\$(28)
- The number of repetitions.
- The code to be repeated.

Type in this new program:

```
10 LPRINT CHR$(30):REM To be sure in character print mode
20 FOR I=1 TO 8
30 LPRINT CHR$(28);CHR$(I);CHR$(I+48);
40 NEXT I
```

Now RUN the program.

Note: Depending on the computer, the second parameter (number of repetitions) is interpreted differently. For example, CHR\$(9) may be interpreted as the TAB command, causing the print head to move to the next TAB position instead of printing characters 9 times. Refer to the owner's manual of your computer for details.

Underline Printing

If you need to underline any text in Character Printing Mode, send the DMP-105 a CHR\$(15). All text that follows this code will be underlined until you send a CHR\$(14) which stops underlining.

Underline is accomplished by two pass printing; this means the second pass creates a continuous unbroken line after the first pass prints the characters to be underlined.

If a Print Head Positioning code is received while the Printer is in an underline-selected condition, the underline is not printed between the home position (left-most printing position) and the dot column position designated by the Print Head Positioning code.

If you enter Graphics Mode while the Printer is in an underline-selected condition, when you return to the Character Printing Mode, the designation of underline is the same as it was before entering Graphics Mode.

Table 13. Underline Printing

Send CHR\$(): (Dec)		(Hex)	To:
15		0F	Start Underline
14		0E	Stop Underline

For example, type in this short program:

```
10 LPRINT CHR$(30);:REM CHARACTER PRINTING
20 LPRINT CHR$(15);:REM START UNDERLINE
30 LPRINT "LEEWAY BUSINESS PRODUCTS "
40 LPRINT CHR$(14);:REM STOP UNDERLINE
50 LPRINT "GIVES GOOD SERVICE"
```

In this example, line 20 turns on the underline and the first line of text (LEEWAY BUSINESS PRODUCTS) is underlined. Line 40 turns the underline off and GIVES GOOD SERVICE is not underlined.

Print Head Positioning

In any mode, you can position the Print Head to a specific dot position.

Every other Print Head position is accessible through the position sequence. The characters stored in ROM can use the half step positions — you can't.

Using the Normal character sets (10 CPI), there are 960 dot positions per line, but only half (480) are accessible by you. The same is true for Compressed and Condensed characters.

Table 14. DMP-105 Print Head Positioning

Character Width	Dots-per-Line	Available Columns
Normal	960	480
Compressed	1152	576
Condensed	1600	800

Elongated characters use the same dot columns, even though the characters are printed twice as wide.

Even if underline is designated, underline does not appear between the home position (the leftmost printing position) and the position designated by the Print Head Positioning code.

To position the Print Head to a specific position, send a (27 16), then two numbers (we'll call them $n1$ and $n2$) that specify the desired position. In other words, just follow this general procedure:

1. Send a Control Code which specifies the Character set (Normal, Condensed, Compressed).
2. Send a CHR\$(27);CHR\$(16) to tell the Printer you want to position the Print Head to print a specific dot column.
3. Tell the Printer which dot column you want to print.
This is a little more complicated and will be explained shortly. For now, just understand that you simply tell the Printer which dot column you want.

4. Tell the Printer what you want to print.

When you want to specify a dot column where printing is to begin, you must first use CHR\$ to send the (27 16) code. Follow this with another two-code sequence which specifies the position. For instance:

```
LPRINT CHR$(27);CHR$(16);CHR$(n1);CHR$(n2)
```

where n1 is a value between 0-3 and n2 is a value between 0-255.

Table 15. Print Head Positioning

If you wish to specify dot column:	n1 must be:	n2 must be:
0-255	0	0-255
256-511	1	0-255
512-767	2	0-255
768-799	3	0-31

Remember! Normal printing allows you to access dot columns up to 479 (n1 = 1, n2 = 223); Compressed printing allows you to access dot columns up to 575 (n1 = 2, n2 = 63); Condensed printing allows you to access up to 799 (n1 = 3, n2 = 31).

Why two numbers (n1 and n2)? The maximum value you can send to the DMP-105 with one number is 255, and clearly you have more than 255 dot positions available.

Those of you who are fans of binary math will recognize that the DMP-105 is interpreting these two numbers as a single 10-bit (b(0)—b(9)) value. The two lower bits of n1 are used as b(8) and b(9).

Note: Use 9.5" wide paper for this next example.

See if you can print a character starting in position 480 in Normal density. n1 = 1 gives 256 of those dots, and 480 - 256 = 224 is the difference to be sent as n2. Type:

```
10 LPRINT CHR$(27);CHR$(16);CHR$(1);CHR$(224);"*"
```

and RUN the program.

Whoops! The asterisk printed at the left edge of the paper. Hmmm! Maybe you need to leave enough room for the asterisk to fit on the end of the line. Try:

```
10 LPRINT CHR$(27);CHR$(16);CHR$(1);CHR$(218);"*"
```

and RUN the program. That's better. It fits nicely at the end of the line. Try this program with the different character densities.

Position is a little like a TAB, but it gets right down to the dot level, giving you much finer control. Although it is available in both print modes, its potential is greatest in Graphics Mode.

If you want to make a real mess on your paper, try:

```
10 LPRINT CHR$(27);CHR$(28);
20 FOR I=1 TO 100
30 LPRINT CHR$(27);CHR$(16);CHR$(1);CHR$(150+I*SIN(I/5));
40 LPRINT "*"
50 NEXT I
```

Get out of the double-width mode and then RUN the program.

Printing Directions

In the Character Printing Mode, either bi- or unidirectional printing is selectable. At power ON, bidirectional printing is selected initially. If you need to select unidirectional printing, send a (27 85 1); and for bidirectional printing, send a (27 85 0).

Table 16. Printing Direction Control Codes

Send CHR\$():		To:
(Dec)	(Hex)	
27 85 1	1B 55 1	Select Unidirectional
27 85 0	1B 55 0	Select Bidirectional

7/Graphics Mode

In Graphics Mode, you no longer have pre-defined characters at your disposal. You are responsible for the positioning and the action of the Print Head.

The DMP-105 allows you to have direct, programmable control over all of the available graphic dots.

How many **across the paper** addressable dot columns are there? That varies, depending on the character style you're using. See Table 17.

Table 17. DMP-105 Print Head Positioning

Character Style	Available Dot Columns
Normal	480
Compressed	576
Condensed	800

How many **up and down** (dot columns) addressable dots are there? The answer is 7.

That means you can specify any one of up to 5,600 individual dots ($7 \times 800 = 5600$).

How do you print just one (or two or three) of those dots in the dot column you want? (For example, how can you print the 3rd dot from the top in the 400th dot column?)

Simple. Just follow this general procedure:

1. Send a Control Code which specifies the character set (Normal, Condensed, Compressed).
2. Send a CHR\$(18) to put the DMP-105 into Graphics Mode.
3. Send a CHR\$(27);CHR\$(16) to tell the Printer you want to position the Print Head to print a specific dot.
4. Tell the Printer in which dot column you wish to print.
This is a little more complicated and will be explained shortly. For now, just understand that you simply tell the Printer which dot column you want.
5. Tell the Printer what you want to print. You can do this a number of ways. Again, this will be explained in more detail shortly. For now, just keep this overall procedure in mind.

When you want to specify a dot column where printing is to begin, you must first use CHR\$ to send the (27 16) code. Follow this with another two-code sequence which specifies the position. For instance:

```
LPRINT CHR$(27);CHR$(16);CHR$(n1);CHR$(n2)
```

Where n1 is a value between 0-3 and n2 is a value between 0-255.

Table 18. Graphic Dot Positioning

If you wish to specify dot column:	n1 must be:	n2 must be:
0-255	0	0-255
256-511	1	0-255
512-767	2	0-255
768-799	3	0-31

Remember! Normal graphic printing allows you to access dot columns up to 479 ($n1 = 1, n2 = 223$); Compressed graphic printing allows you to access dot columns up to 575 ($n1 = 2, n2 = 63$); Condensed graphic printing allows you to access up to 799 ($n1 = 3, n2 = 31$).

Even though dot columns greater than 255 exist, you cannot send values greater than 255. That is, `CHR$(400)` is not allowed — you must break it into a two-byte value.

For instance, to draw a vertical bar at dot column 144, try this program:

```
10 LPRINT CHR$(18)
20 LPRINT CHR$(27);CHR$(16);CHR$(0);CHR$(144);CHR$(255)
```

(Don't worry, that last `CHR$(255)` will be discussed shortly.)

In line 10, `CHR$(18)` puts the Printer into Graphics Mode and, in line 20, `CHR$(27);CHR$(16)` tells it to get ready to position the Print Head. (Note that `CHR$(0)` is necessary.)

Try this line to print a vertical bar at the rightmost available dot column — 799.

```
10 LPRINT CHR$(27);CHR$(20);CHR$(18);CHR$(27);CHR$(16);
CHR$(3);CHR$(31);CHR$(255);
```

What happens is:

- `CHR$(27);CHR$(20)` puts the DMP-105 into the Condensed character set.
- `CHR$(18)` puts the Printer into Graphics Mode.
- `CHR$(27);CHR$(16)` tells the DMP-105 to get ready to position the Print Head.
- `CHR$(3)` tells the Printer that the position will be greater than 768.
- `CHR$(31)` specifies the last available dot column.

Note: If you used `CHR$(32)` in this line instead of `CHR$(31)`, the DMP-105 would **wrap-around** to the first dot column in the next line.

Printing Graphics Patterns

By now, you should be adept at positioning the Print Head. But you also need to be able to tell the DMP-105 what to print once the Head is positioned.

Remember that we said there were 7 vertical dots in each dot column. You can print any or all of these dots in any combination you want.

Look back at the sample programs used when we talked about Print Head positioning. Do you remember the last part of the program line (`CHR$(255)`) which always printed a vertical bar? That's an example of all 7 dots being printed at once.

Try printing just the top dot of that last dot column (799):

```
10 LPRINT CHR$(27);CHR$(20);CHR$(18);CHR$(27);CHR$(16);
CHR$(3);CHR$(31);CHR$(129);
```

How does CHR\$(129) print just the top dot?

Even though the 7 dots in a dot column are in a vertical row, they are not numbered sequentially down from 1 to 7. Table 19 describes the numbering system you must use with the DMP-105 when specifying an individual dot:

Table 19. DMP-105 Addressable Dot Numbering System

Dot #:	Dot:	Number You Must Use To Print the Dot:
1	.	129
2	.	130
4	.	132
8	.	136
16	.	144
32	.	160
64	.	192

For instance, you've already seen how to print the top dot in the column, but to print the bottom dot, change the program line to:

```
10 LPRINT CHR$(27);CHR$(20);CHR$(18);CHR$(27);CHR$(16);
CHR$(3);CHR$(31);CHR$(192);
```

This is fine if you want to print an individual dot, but how do you print a combination of dots?

That's actually quite simple, too.

1. Specify the Dot # (1-64, see Table 19) that represents the individual dots you want to print.
2. Add those individual Dot #'s together.
3. Add the sum of the combined Dot #'s to 128.

For example, if you want to print the first dot (Dot #1), the fourth dot (Dot #8), and the last dot (Dot #64), add them together: $1 + 8 + 64 = 73$. Then add the sum (73) to 128: $73 + 128 = 201$. Use 201 as the addressable dot pattern in the form CHR\$(201):

```
10 LPRINT CHR$(27);CHR$(20);CHR$(18);CHR$(27);CHR$(16);
CHR$(3);CHR$(31);CHR$(201);
```

Remember how CHR\$(255) printed a solid (all dots printed) vertical bar. Try out the formula on that:

$$1 + 2 + 4 + 8 + 16 + 32 + 64 = 127 + 128 = 255$$

The following sample program line will print a box with a line through the middle:

```
10 LPRINT CHR$(27);CHR$(20);CHR$(18);CHR$(27);CHR$(16);
CHR$(3);CHR$(31);CHR$(255);CHR$(210);CHR$(201);CHR$(201);
CHR$(201);CHR$(255);
```

Now to flex our muscles.

Type in NEW **(ENTER)**

```
10 LPRINT CHR$(18)
20 S=1:N=128
30 FOR I=1 TO 20:S=-S
40 FOR J=0 TO 6
50 IF S<0 THEN N=N+2^(6-J) ELSE N=N-2^J
90 LPRINT CHR$(N);
100 NEXT J:NEXT I
120 LPRINT CHR$(30)
```

RUN the program. Be prepared for a pause; it takes time to fill the print buffer.

This program alternately adds and subtracts powers of two to the current code pattern stored in the variable N. The net effect is to add or remove a single dot from the preceding dot pattern.

Line Feed

In Graphics Mode, it is assumed that you want to print rows of graphics one right after another, each 7 dots high. Therefore, Graphics Mode provides only one Line Feed. A single Line Feed advances the paper 7 dots or approximately 0.1 inch. This small paper advance allows for continuous printing without unwanted space between lines.

Modify the current program to demonstrate this fixed Line Feed. Add or change:

```
20 S=1:N=128
50 IF K=1 THEN 80
60 IF S<0 THEN N=N+2^J ELSE N=N-2^(6-J)
70 GOTO 90
110 LPRINT:NEXT K
```

and RUN the program.

These lines infiltrate the current loop and produce a mirror image of the first pass of the Print Head. The **LPRINT** in line 110 causes the Line Feed between passes.

Repeat Function

CHR\$(28) will tell the DMP-105 to repeat a graphic pattern a specified number of times.

The format for the Repeat Function is:

repeat code + number of times to repeat + what to repeat

For instance, **LPRINT CHR\$(28);CHR\$(15);CHR\$(255)** will print the solid vertical bar 15 times.

Change line 90 to:

```
90 LPRINT CHR$(28);CHR$(15);CHR$(N);
```

and RUN the program.

Print Density

Horizontal dot density in Graphics Mode is the same as that of the character width prior to entering Graphics Mode.

If you have been using Standard font style and then enter Graphics Mode, resolution will be 480 dots per line; if you have been using Compressed characters before entering Graphics Mode, resolution will be 576 dots per line; if you have been using Condensed characters, resolution will be 800 dots per line. Add to the current sample program:

```
5 LPRINT CHR$(27);CHR$(23);"COMPRESSED CHARACTER WIDTH";
```

and RUN it.

Line 5 activates the Compressed character set. Graphics are then printed in Compressed character density.

Leaving Graphics Mode

CHR\$(30) is used to exit Graphics Mode. It returns the DMP-105 to the CP Mode. In addition, all the previous conditions, such as underline and character style, are restored. Change the sample program to:

```
90 LPRINT CHR$(N);  
130 LPRINT "STILL IN COMPRESSED MODE"
```

and RUN it.

Sure enough, the Compressed mode is still alive and well.

Mixing Modes on the Same Line

The fact that character density is unaffected as the DMP-105 moves in and out of Graphics Mode is a blessing when mixing Text and Graphics on the same line. It simplifies the calculation of the number of dots per line.

Freehand Drawing

Having high-resolution graphics at your disposal is great, but you must realize that it requires plenty of data. The Computer can do most of the work in drawing figures that can be described by a mathematical function. Freehand drawings, on the other hand, require translating the figure into a matrix of dots, then calculating the dot printing combinations for each Print Head position. Since there are 7 dots available for graphics, separate the matrix into rows 7 dots high.

The numbers can be stored in DATA statements. To conserve memory and typing time, store the data as numbers from 0 to 127, then add 128 as you send them to the Printer. Enter these sample DATA lines:

```
NEW (ENTER)  
120 DATA 999  
160 DATA 13,12,112,999  
190 DATA 32,32,18,18,8,15,999  
210 DATA 16,16,8,8,4,4,2,2,1,1,999
```

The 999's will be used to signify the end of a line. The other numbers are between 0 and 127. Now for the program to read the numbers, add 128, then send them to the Printer.

```

10 LPRINT CHR$(18)
20 FOR R=1 TO 4
30 READ N:IF N=999 THEN B0
40 LPRINT CHR$(128+N);:GOTO 30
B0 LPRINT:NEXT R
90 LPRINT CHR$(30)
100 LPRINT "DMP105"

```

Now RUN the program.

Not much to brag about yet. Maybe what it needs is to be jazzed up to repeat a number several times. A good approach is to use negative numbers to indicate the number of repetitions followed by the number to be repeated. Add:

```

120 DATA 17,-2,33,34,-4,66,68,-4,4,-5,8,-5,16,-5,32,
        -5,64,999
130 DATA 46,96,80,72,68,66,33,16,812,94,-7,127,-5,126
180 DATA 95,79,71,67,65,32,16,8,4,2,1,-4,0,3,71,67

```

Don't RUN it yet!

In line 120, the sequence -4,66 is used to mean four 66s: 66,66,66,66. You must modify the program to recognize the negative numbers. Change:

```

40 IF N>=0 THEN LPRINT CHR$(128+N);:GOTO 30
50 READ M
60 LPRINT CHR$(28);CHR$(-N);CHR$(128+M);
70 GOTO 30

```

and RUN the program.

The figure still doesn't look like much. Add the remaining DATA lines and see what you've been working on.

```

110 DATA -7,0,-2,64,-2,96,80,-2,72,-2,-2,100,-1,114,-2,57
140 TADA -5,124,-2,120,-3,121,-2,113,-3,114,90,90, 2,100
150 DATA -2,116,92,8,72,64,32,32,16,80,104,72,5,5,3
170 DATA 127,-4,64,3,-3,2,3,-5,15,-5,31,-5,63,-6,127
200 DATA -5,0,-5,1,-5,2,-5,4,-5,8,-5,19,-5,38,-4,64,
        127,32,32

```

RUN the program.

Now that's worth the effort!

Appendix A/Control Code Summary

Dec.	Code Hex.	Character Printing Mode	Graphics Mode	Remarks
00	00	Ignored	Ignored	
01	01	Ignored	Ignored	
10 or 138	0A or 8A	Executive Line Feed (Execute LF in accordance with information latched)	7/72" Line Fee (Executive) 8A hex.: Printing data	
13 or 141	0D or 8D	Carriage Return (When NL, LF pitch is latched one.)	Carriage Return (When NL, LF pitch is 7/72" per line.) 8D hex.: Printing data	NL/CR Code Selectable
14	0E	End Underline	Ignored	
15	0F	Start Underline	Ignored	
18	12	Select Graphics Mode	Ignored	
27 14	1B 0E	Start Elongation	Start Elongation	
27 15	1B 0F	End Elongation	End Elongation	
27 16 n1 n2	1B 10 n1 n2	Positioning (3 pitches are available.) (n1, n2 indicate dot position from Home position.)	Positioning (3 pitches are available.) (n1, n2 indicate dot position from Home position.)	n1, n2: Binary value ***
27 19	1B 13	Select Standard character	Ignored	
27 20	1B 14	Select Condensed character	Ignored	
27 21	1B 15	Set CR = CR (No motion)	Ignored	
27 22	1B 16	Set CR = LF + CR (NL) (No motion)	Ignored	
27 23	1B 17	Select Elite character	Ignored	
27 28	1B 1C	Set Half Forward Line Feed (No motion)	Ignored	
27 31	1B 1F	Start Bold	Ignored	
27 32	1B 20	End Bold	Ignored	
27 54	1B 36	Set Full Forward Line Feed (No motion)	Ignored	

Dec.	Code		Character Printing Mode	Graphics Mode	Remarks
	Hex.				
27	1B		Set 3/4 Forward	Ignored	
56	38		Line Feed (No motion)		
27	1B		Select Bidirectional Printing	Ignored	
85	55				
0	0				
27	1B		Select Unidirectional Printing	Ignored	
85	55				
1	1				
27	1B		n/72" Forward	n/72" Forward	
90	5A		Line Feed (Executive)	Line Feed (Executive)	
n	n				
27	1B		Set n/72" Forward	Ignored	
91	5B		Line Feed (No motion)		
n	n				
28	1C		Repeat Print Data (Undefined Code is changed to X)	Repeat Print Data (IF MSB = 0, Data is ignored.)	
n1 n2	n1 n2				
30	1E		Ignored	End Graphics Mode	
Other Codes in Function Area (02 to 31 dec.) (02 to 1F hex.)			Prints X	Ignored	
Other Codes in Function Area (128 to 159, 192 to 223 dec.) (80 to 9F, C0 to DF hex.)			Prints X	(Printing Data)	

Appendix B/Interface

Parallel Interface

Interface Connector

Type 36-Pin Receptacle
Model 552742-1 or equivalent
Manufacturer AMP or equivalent

Pin Assignment



Signals

Signal Pin	Name of Signal	Signal Pin	Name of Signal
1	STROBE	19	0 V (Return for 1)
2	DATA 1	20	0 V (Return for 2)
3	DATA 2	21	0 V (Return for 3)
4	DATA 3	22	0 V (Return for 4)
5	DATA 4	23	0 V (Return for 5)
6	DATA 5	24	0 V (Return for 6)
7	DATA 6	25	0 V (Return for 7)
8	DATA 7	26	0 V (Return for 8)
9	DATA 8	27	0 V (Return for 9)
10	ACK	28	0 V (Return for 10)
11	BUSY	29	0 V (Return for 11)
12	PE (Paper Out)	30	0 V
13	BUSY	31	NC (Not Connected)
14	0 V	32	FAULT (Printer Error Condition)
15	NC (Not Connected)	33	NC (Not Connected)
16	0 V	34	NC (Not Connected)
17	CHASSIS GROUND	35	NC (Not Connected)
18	+5 V (80 mA Maximum)	36	NC (Not Connected)

Parallel Interface Signals

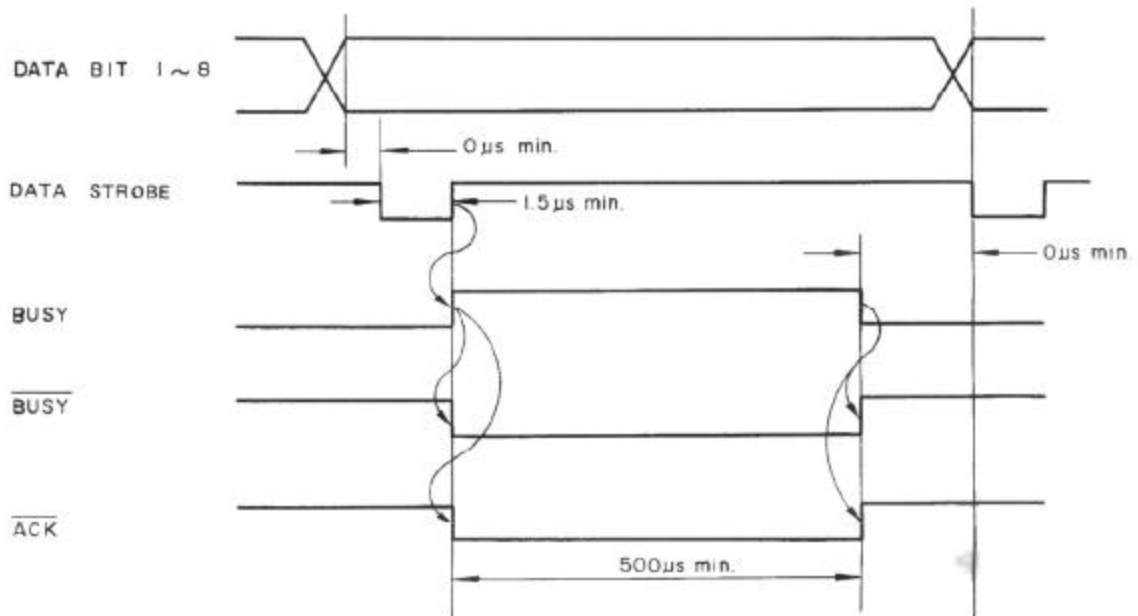

Timing Diagram

DB1-DB8 — Host Generated

Data Bits DB1-DB8 contain ASCII character data information. Data bit levels are positive true logic.

ACKNOWLEDGE — Printer Generated

The ACK signal is a negative-going signal which indicates, by the rising edge, that the Printer is no longer busy.

BUSY — Printer Generated

The BUSY signal goes positive to indicate when the Printer cannot accept new data from the Host, or some Fault condition has occurred. Timing is illustrated in the Timing Diagram.

PAPER OUT (PE) — Printer Generated

The paper out signal is a positive-going pulse which indicates that the Printer is out of paper or that the Printer is not ready to receive data.

$\overline{\text{BUSY}}$ — Printer Generated

The $\overline{\text{BUSY}}$ signal is the logical inverse of BUSY.

$\overline{\text{FAULT}}$ — Printer Generated

The $\overline{\text{FAULT}}$ line is a negative-going signal that indicates there is a fault condition present; i.e., paper out, logic fault, off-line condition, or other mechanical fault.

STROBE — Host Generated

The STROBE signal is a negative-going signal which indicates, by the rising edge, that the Host sends data to the Printer.

CHASSIS GROUND

This line is connected to the chassis of the Printer.

5 V — Printer Generated

This line is connected to the Printer's logic +5 V line.
Maximum supply current is 80 mA.

Parallel Interface Receivers and Drivers

All I/O Signals are TTL-compatible.

Receiver

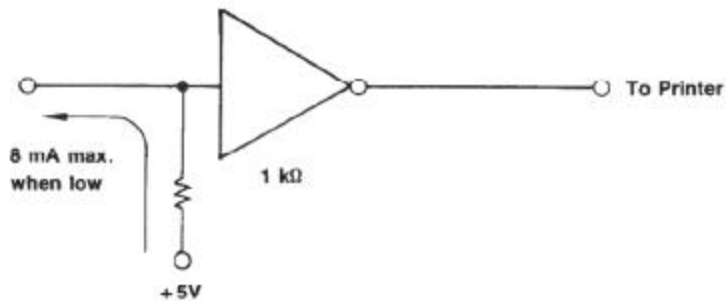

Driver

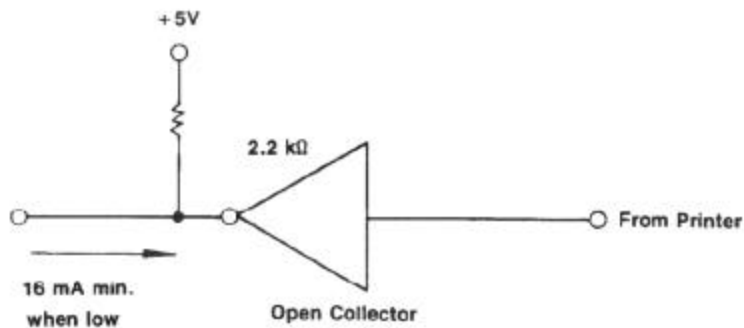

Note: Printer-generated signals, **BUSY**, **FAULT**, **PE**, **BUSY**, and **ACK**, have a 2.2 kohm pull-up resistor.

Serial Interface

Serial Interface is selected by setting Function Selection Switch 1 to ON.

Transmission Rate is selected from two rates (600 BPS and 2400 BPS) by Function Selection Switch 2; **OFF** designates 2400 BPS and **ON** designates 600 BPS.

Function Selection Switch 2 is activated only in a Serial Interface Condition.

General Specifications of Serial Interface

Standard	Meet with RS-232C Serial
Baud Rate	600 or 2400 BPS Serial
Parity	Non-parity
Buffer	Up to 134 characters
Data Bit	8
Start Bit	1 Space bit
Stop Bit	1 or 2 Mark bits
Signal Cable	15 m Max.

Interface Connector and Signals

Type	4-Pin DIN Jack (Receptacle)
Model	TCS 4640-01A or equivalent
Manufacturer	HOSHIDEN CO., LTD. or equivalent

Pin Assignment and Signals

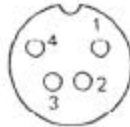

Pin No.	Signal
1	NS
2	BUSY
3	GND (0 V)
4	DATA

DATA — To Printer

Signals on this circuit are generated by the Computer for transmission of data to the Printer.

BUSY — From Printer

This signal indicates to the Computer whether or not the Printer can accept data. The **OFF** condition (low) indicates that the Printer is BUSY and cannot accept any more data.

Interface Timing and Signal Level

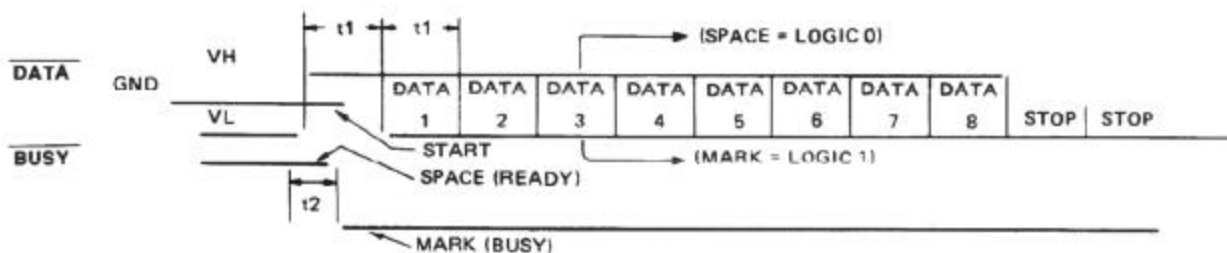

$$+3\text{ V} < V_H < +25\text{ (SPACE)}$$

$$-25\text{ V} < V_L < -3\text{ V (MARK)}$$

Baud Rate	t_1	t_2
600 BPS	1.67 msec.	0.83 msec.
2400 BPS	0.42 msec.	0.21 msec.

Remarks on Serial Interfacing Conditions

- When a Framing **ERROR** is detected, the Printer will print only one X data, then stop printing until the data line goes to VL. In Graphics Mode, this X data is unprintable code, so no printing will be performed.
- The Printer checks only the first stop-bit and ignores the second stop-bit when a two-stop-bit condition exists.
- When a string of data is transmitted to the Printer in Serial Interfacing Mode, if each item of data is transmitted intermittently (every one second or more), printing will be performed every second.

Appendix C/Character Sets

The DMP-105 has 158 dot-matrix patterns in the ROM (Read Only Memory). The following is a table of the Character Codes.

The printable characters may be classified as follows.

- Condensed or
Condensed Elongated ASCII 94
- Compressed or
Compressed Elongated European Symbol 32
Block Graphic 30
- Standard or
Standard Elongated

94 ASCII Code

ASCII Character Sets

Code			Char.	Code			Char.	Code			Char.
Dec.	Hex	Oct.		Dec.	Hex	Oct.		Dec.	Hex	Oct.	
32	20	40	(Space)	64	40	100	@	96	60	140	ˆ
33	21	41	!	65	41	101	A	97	61	141	a
34	22	42	"	66	42	102	B	98	62	142	b
35	23	43	#	67	43	103	C	99	63	143	c
36	24	44	\$	68	44	104	D	100	64	144	d
37	25	45	%	69	45	105	E	101	65	145	e
38	26	46	&	70	46	106	F	102	66	146	f
39	27	47	'	71	47	107	G	103	67	147	g
40	28	50	(72	48	110	H	104	68	150	h
41	29	51)	73	49	111	I	105	69	151	i
42	2A	52	*	74	4A	112	J	106	6A	152	j
43	2B	53	+	75	4B	113	K	107	6B	153	k
44	2C	54	,	76	4C	114	L	108	6C	154	l
45	2D	55	—	77	4D	115	M	109	6D	155	m
46	2E	56	.	78	4E	116	N	110	6E	156	n
47	2F	57	/	79	4F	117	O	111	6F	157	o
48	30	60	0	80	50	120	P	112	70	160	p
49	31	61	1	81	51	121	Q	113	71	161	q
50	32	62	2	82	52	122	R	114	72	162	r
51	33	63	3	83	53	123	S	115	73	163	s
52	34	64	4	84	54	124	T	116	74	164	t
53	35	65	5	85	55	125	U	117	75	165	u
54	36	66	6	86	56	126	V	118	76	166	v
55	37	67	7	87	57	127	W	119	77	167	w
56	38	70	8	88	58	130	X	120	78	170	x
57	39	71	9	89	59	131	Y	121	79	171	y
58	3A	72	:	90	5A	132	Z	122	7A	172	z
59	3B	73	;	91	5B	133	[123	7B	173	{
60	3C	74	<	92	5C	134	\	124	7C	174	
61	3D	75	=	93	5D	135]	125	7D	175	}
62	3E	76	>	94	5E	136	^	126	7E	176	~
63	3F	77	?	95	5F	137	—				

Note: The following characters descend by one dot:
Small Letters g,p,q,y,j,
(Underline);;

32 European Symbol Code

Standard, Compressed or Condensed Character Set

Code			Char.
Dec.	Hex	Oct.	
160	A0	240	'
161	A1	241	à
162	A2	242	ç
163	A3	243	€
164	A4	244	˘
165	A5	245	μ
166	A6	246	°
167	A7	247	▼
168	A8	250	†
169	A9	251	§
170	AA	252	⊗
171	AB	253	⊙
172	AC	254	¼
173	AD	255	¾
174	AE	256	½
175	AF	257	₹
176	B0	260	¥
177	B1	261	Á
178	B2	262	Ô
179	B3	263	Û
180	B4	264	é
181	B5	265	˘
182	B6	266	ä
183	B7	267	ö
184	B8	270	ü
185	B9	271	β
186	BA	272	™
187	BB	273	ê
188	BC	274	ú
189	BD	275	è
190	BE	276	˘
191	BF	277	ƒ

Notes: 1 The optimizer function allows the following: If a spacing code is received, the Carriage moves only the shortest distance, and the action will take place without unnecessary movement. This saves printing time. When character data is sent to the Printer within a one-second interval, the Printer automatically stores it until: (1) Function codes are sent, (2) the interval is greater than one second. Printing is then executed.

2 The following characters descend by one dot.

ç, μ, §, ß, ƒ

30 Block Graphic Code

Standard, Compressed or Condensed Set

Code			Char.	Code			Char.
Dec.	Hex	Oct.		Dec.	Hex	Oct.	
224	E0	340	(Blank)	240	F0	360	┌
225	E1	341	■	241	F1	361	—
226	E2	342	■	242	F2	362	┐
227	E3	343	■	243	F3	363	└
228	E4	344	■	244	F4	364	┘
229	E5	345	■	245	F5		
230	E6	346	■	246	F6	366	└
231	E7	347	■	247	F7	367	┘
232	E8	250	■	248	F8	370	└
233	E9	351	■	249	F9	371	┘
234	EA	352	■	250	FA	372	+
235	EB	353	■	251	FB	373	▾
236	EC	354	■	252	FC	374	▴
237	ED	355	■	253	FD	375	▾
238	EE	356	■	254	FE	376	▴
239	EF	357	■				

Note: These characters are composed of six vertical dots. When using these codes to prepare diagrams, Line Feed should be set to **Half Forward Line Feed**. If another paper feed pitch is used, the diagram will not be accurate.

Appendix D/Programming Information

The following items should be considered when you program the Computer.

1. When Printer Power is turned on:
 - Optional functions are selected according to the setting of the Function Selection Switches.
 - If CP Mode is selected, Full Forward Line Feed is set.
 - NL (CR + LF) is selected.
 - Underline is not set.
 - Standard character is set (not Elongated and not Bold).
 - Buffer memory is completely cleared.
2. Every character font can be intermixed with another style of character in the same line. However, the Printer will insert dot spaces to insure that the new dot position is valid for the current character size. This may cause unexpected automatic wrap-around. To prevent this, intermix characters only on short lines, or don't mix character sizes on the same line.
3. Elongated (Double-width) characters and Underline are not terminated at the end of the line and such printing continues until a terminating command is received.
4. You should avoid wrap-around. Wrap-around will disturb the dot count of the text in a line.
5. In the Repeat Data commands, printable characters can be repeated as many times as provided for in the count number. If any function code is received for repetition, it will be considered an invalid code (X).
6. POS commands can be used at any carriage position. If a designated dot column address is in the current text which is already printed out, overprint will occur.
7. Under Block Graphic printing, Half Forward Line Feed should be used for printing diagrams.
8. Line Feed in Graphics Mode is different from Line Feed pitches in the CP Mode. An odd vertical spacing is generated in Graphics Mode. Consider the following relationship between Line Feed pitches.
 - 11 times of Full Line Feed = 18 times of Graphics Line Feed
 - 11 times of Half Line Feed = 9 times of Graphics Line Feed
9. Graphic printing can be intermixed with character printing in the same line. Dot density in Graphics Mode is the same as the density of the former character style.
10. Bold character mode is useful for headings or titles.

Programming Examples

Note to Model II Programmers:

If the Printer goes off-line during a print operation, and remains off-line for a certain period of time, Model II TRSDOS will present an error message. Application programs should be written to trap such errors, inform the operator of the error condition, and give the operator a chance to correct the condition and continue printing. If it is a BASIC applications program, and I/O error will occur and the operator may type `CONT` (**ENTER**) to continue.

The BASIC statements `LPRINT` and `LLIST` output to the Line Printer. See your Computer's reference manual for syntax details. If you have a Color Computer, read `LPRINT` as `PRINT #-2,`.

Examples:

`LLIST`

Lists the resident program to the Printer.

`LPRINT "THIS IS A TEST."`

Prints the message in quotes and tells the Printer that the next printable character brings a new line.

`LPRINT "THIS IS PART OF A LINE"; LPRINT "THIS IS THE REST"`

Prints both messages on the same line (because of the semicolon). The next printable character received starts a new line.

`LPRINT "SMALL";CHR$(27);CHR$(14);"LARGE";CHR$(27);CHR$(15);"SMALL AGAIN"`

Prints both normal and elongated characters on the same line.

`LPRINT CHR$(27);CHR$(20);"CONDENSED";CHR$(27);CHR$(23);"COMPRESSED";CHR$(27);CHR$(19);"STANDARD"`

Prints condensed, compressed, and standard characters in the same line.

`LPRINT "START";CHR$(27);CHR$(56);CHR$(138);"ONE LINE";CHR$(138);"TWO LINE"`

Prints these letters at 3/4 line pitch.

`LPRINT "START";CHR$(27);CHR$(90);CHR$(12);"FULL ONE LINE";CHR$(27);CHR$(90);CHR$(8);"2/3 LINE"`

Prints these letters at full line pitch, then at 2/3 line pitch (8/72" = 1/9").

`LPRINT CHR$(15);"UNDERLINE";CHR$(14);"WITHOUT UNDERLINE"`

Prints both messages underlined and non-underlined in the same line.

`LPRINT CHR$(27);CHR$(31);"BOLD LETTERS";CHR$(27);CHR$(32);"NORMAL LETTERS"`

Prints Bold letters and Normal letters in the same line.

`LPRINT CHR$(28);CHR$(9);"ABC"`

Prints 9 characters of **A** and one character **BC**.

`LPRINT CHR$(13);CHR$(27);CHR$(16);CHR$(01);CHR$(44);"300TH POSITION"`

Prints above message from 300th column address.

`LPRINT CHR$(18);CHR$(255);CHR$(247);CHR$(227);CHR$(193);CHR$(227);CHR$(247);CHR$(255);CHR$(30)`

Prints a special symbol in Graphics Mode.

`LPRINT CHR$(27);CHR$(21);"XXXX";CHR$(13);"—";CHR$(27);CHR$(22);"0000"`

Prints **XXXX** and then **0000** in the next line.

Appendix E/Care and Maintenance

1. Always plug the Printer into a 3-wire grounded receptacle.
2. Be sure that the Top Cover is closed and secured while in operation. If it is open, the Printer is OFF-LINE and printing is impossible.
3. Never operate the Printer without paper. If paper used is less than 4" wide, take care to see that printing does not exceed paper width.
4. Avoid leaning objects against the Printer or placing anything on top. If any object is accidentally dropped into the machine, turn power off and carefully remove the object.
5. Be sure to turn power OFF before replacing ribbon.

Note: When you turn power OFF, all data stored in the Printer's buffer will be lost; keep this in mind as you perform routine maintenance. Remember that toggling the Printer's power can also cause erratic operation of the CPU.

6. Use only lint-free cloth to clean the Printer surface. Do not use solvents or harsh cleaning agents. Mild detergent solution or desk top cleanser may be used sparingly.
7. Keep hands away from the Carriage mechanism while the Printer is in operation. Since the Carriage moves with considerable force, inserting your hand would be extremely hazardous.
8. The Printer must be kept dry. If water is accidentally spilled on the machine, turn power OFF immediately and wipe it dry. Do not turn power ON until completely dry.
9. If printed material is too light or too dark, check to see if the Print Head is positioned properly. If necessary, contact your local Radio Shack Computer Center.

Care

- Do not use organic solvents or alcohol when cleaning the cover.
- Never operate the Printer when the Top Cover is open.
- Never set the Printer where it is exposed to direct sunlight.
- Prevent the Printer from vibrating during operation.
- Graphics printing places a heavier load on the Print Head than do text characters. If you print too many block graphic characters or graphics without pausing, the Print Head could overheat, causing the fuse to blow.

When you must print graphics continuously, be sure to pause the printing for at least one minute after each 1/6th paper is printed (assuming a 9" × 11" page). This will prevent the unit from overheating. In terms of load on the Print Head, the underline falls into the graphics category, and should be treated as such.

Maintenance

- If the Print Head becomes clogged with ribbon material or paper lint, carefully remove such material with a finely pointed tool (preferably a toothpick). This should be regularly checked.
- A Print Head's life expectancy is approximately 2000 hours (in other words, if you use the Printer two hours a day on the average, the Print Head should be changed every 32 months). When poor print quality, sticking ribbon, or bent character printing occurs, you should have the Print Head replaced by a Radio Shack service technician.

- After cleaning with a soft cloth, lightly oil the *carriage guide* with a high-grade ester lubricating oil or with high-grade sewing machine oil. (This should be done at least every six months.) Lubricate the *platen removing shaft*, the *ribbon feed revolving shaft*, and the *gear revolving shaft*, using molybdenum disulfide compound or another high-grade lubricating grease.
- Because ink from the paper can get on the Paper Bail rollers, we suggest a periodic cleaning of the rollers. Use 90% isopropyl alcohol to remove ink build up on the rollers as often as necessary.

If You Have Problems. . .

If the Printer fails to operate properly, try to solve the trouble by using the following table.

SYMPTOM	INSPECTION AND ADJUSTMENT
Printer does not operate when Power switch is turned ON . Printer stops before paper runs out.	<ul style="list-style-type: none"> • Is power cord properly connected? • Is power source voltage too low? Printer should stop if below 90% of rated voltage. • If you cannot hear any sound or see any movement, remove the Printer Cover and check the fuses.
Printer stops.	<ul style="list-style-type: none"> • Is paper loaded properly? • Is carriage guide dirty? If so, clean it by using a soft cloth and lubricate it with a high-grade ester lubricating oil or high-grade sewing machine oil. • Has some object dropped inside the Printer? • If nothing is wrong, turn power OFF, then ON.
Ribbon fails to track properly.	<ul style="list-style-type: none"> • Is ribbon cassette properly set? • Has ribbon come loose from the print head ribbon guide? • Is ribbon so worn that it does not feed smoothly from the cassette? • Has the Print Head reached its life expectancy? A worn out head will stick to ribbon and interfere with smooth movement. Replace the Print Head with a new one.
Poor print quality or smudging on paper.	<ul style="list-style-type: none"> • Is ribbon old and/or worn? • Is the Print Head set at the proper position? • Is the tip of the Print Head dirty? If dirty, clean it off with a toothpick or needle. • Did you clean the ribbon guide posts when you replaced the ribbon cassette? If dirty, remove the ribbon cassette and clean the ribbon guide posts with a soft dry cloth.
Erratic operation or wrong character printing.	<ul style="list-style-type: none"> • Is the interface cable and/or connector damaged? • Are interface connectors inserted properly to the Computer or to the Printer?
The paper cannot be advanced smoothly.	<ul style="list-style-type: none"> • Is paper loaded properly into the entrance of the insertion opening? • Is any obstacle preventing smooth paper motion? • Does paper stick or tear because of the side guide pins?

Note: If the trouble cannot be corrected after making the above check-up and adjustment, check for secure contacts of all connectors. If you can't eliminate the problem, take the unit to your Radio Shack Store or Computer Center for repair.

Printing Limits (Duty Cycle)

The DMP-105 does have its limits when it comes to heavy, continuous printing. Depending upon the type of printing being performed, those limits vary.

DMP-105 Printing Limits			
Type of Printing		%	Number of Pages
Character	at	100%	for 8
Graphics		100%	1/2
Block Graphic		100%	1/3

Note: These figures are based on an 80-column printing width. 100% printing would mean every column is printed.

Appendix F/Schematic Diagram

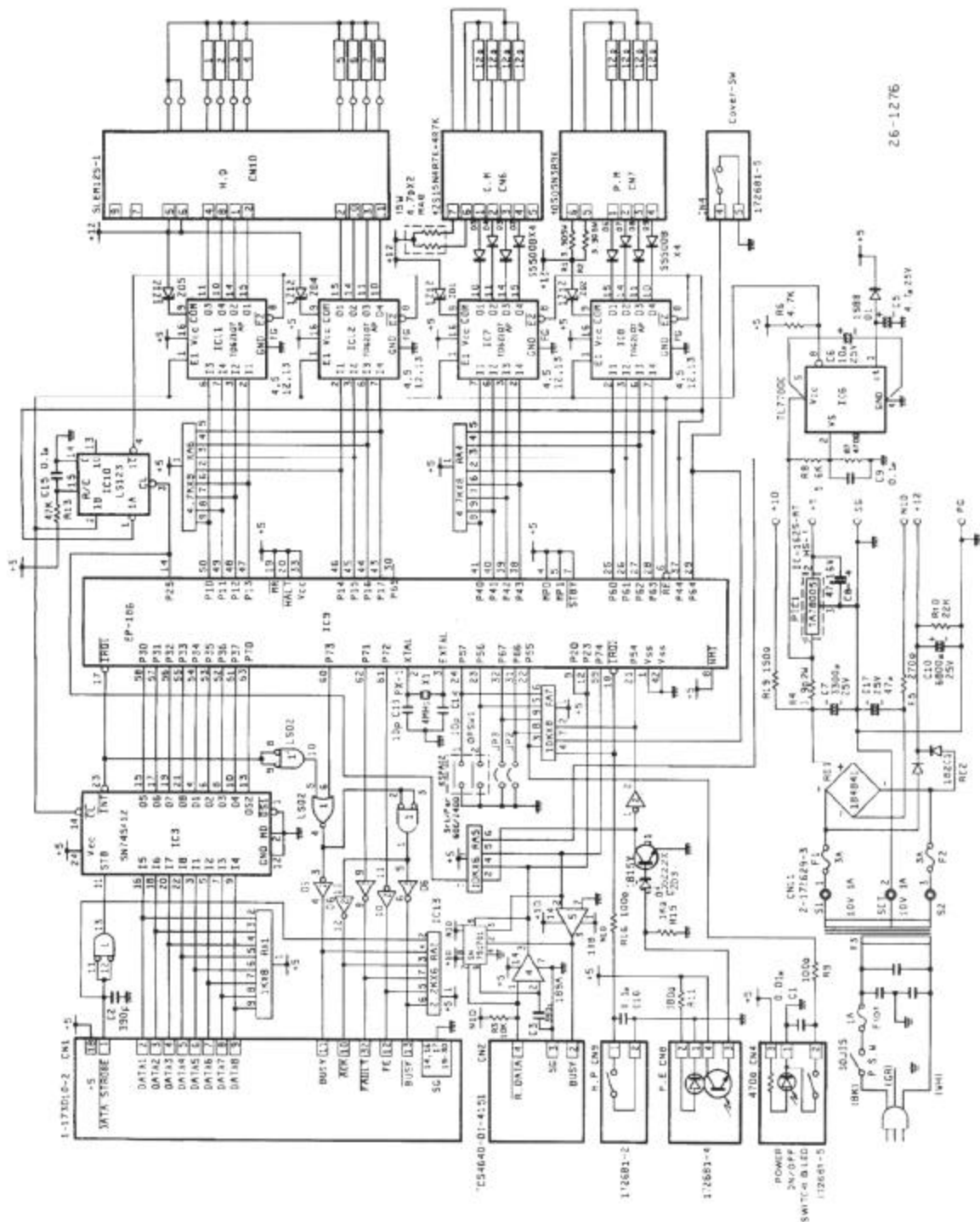

Appendix G/Specifications

Printing Speed (character per second)	
Standard 10 CPI	80
Elongated Standard 5 CPI	40
Compressed 12 CPI	65
Elongated Compressed 6 CPI	32.5
Condensed 16.7 CPI	46
Elongated Condensed 8.3 CPI	23
Characters Per Line	
Standard 10 CPI	80
Elongated Standard 5 CPI	40
Compressed 12 CPI	96
Elongated Compressed 6 CPI	48
Condensed 16.7 CPI	133
Elongated Condensed 8.3 CPI	66
Dots Per Character	
Standard 10 CPI	12
Elongated Standard 5 CPI	24
Compressed 12 CPI	12
Elongated Compressed 6 CPI	24
Condensed 16.7 CPI	12
Elongated Condensed 8.3 CPI	24
Vertical Spacing	12, 6, 8 lines per inch (Computer selectable), 7/72" and n/72" (n/12 line feed) available.
Dots Per Line	
Standard 10 CPI	960 dots
Elongated Standard 5 CPI	960 dots
Compressed 12 CPI	1152 dots
Elongated Compressed 6 CPI	1152 dots
Condensed 16.7 CPI	1600 dots
Elongated Condensed 8.3 CPI	1600 dots
Character set	
Standard, Compressed, Condensed	ASCII 94, European Symbols 32, Block Graphics 30
Interface	
Parallel	8-bit with strobe signal
Serial	8-bit, Baud rate selectable (600 BPS or 2400 BPS).
Print Head Life	
Preventive Maintenance	50 million characters typical Normally every 6 months
Temperature and Humidity Range	
Operating	32°F ~ 110°F (0°C ~ 43.3°C) 40 ~ 80% RH
Storage	-40°F ~ 160°F (-40°C ~ 71°C) 20% ~ 90% RH
Paper	
Fanfold Paper	4" ~ 9.5" wide with guide holes
Single Sheets	4" ~ 9.5" wide, good quality, 40 ~ 60 kg (14 ~ 22 lb)
Copy Paper	1 original, 1 copy 34 kg (11 lb) non-carbon paper
Ribbon Cassette	Catalog Number 26-1418
Power Requirements	120 VAC, 60 Hz (for USA/Canada), or 220 V/240 VAC, 50 Hz (for European and Australian models). 22 W maximum.

