

TRS-80[®]

DMP-120

Operation Manual Catalog Number 26-1255



Radio Shack

TRS-80

**COMPUTER
PRODUCTS**

CUSTOM MANUFACTURED IN USA BY RADIO SHACK, A DIVISION OF TANDY CORPORATION

SERVICE POLICY

Radio Shack's nationwide network of service facilities provides quick, convenient, and reliable repair services for all of its computer products, in most instances. Warranty service will be performed in accordance with Radio Shack's Limited Warranty. Non-warranty service will be provided at reasonable parts and labor costs.

Because of the sensitivity of computer equipment, and the problems which can result from improper servicing, the following limitations also apply to the services offered by Radio Shack:

1. If any of the warranty seals on any Radio Shack computer products are broken, Radio Shack reserves the right to refuse to service the equipment or to void any remaining warranty on the equipment.
2. If any Radio Shack computer equipment has been modified so that it is not within manufacturer's specifications, including, but not limited to, the installation of any non-Radio Shack parts, components, or replacement boards, then Radio Shack reserves the right to refuse to service the equipment, void any remaining warranty, remove and replace any non-Radio Shack part found in the equipment, and perform whatever modifications are necessary to return the equipment to original factory manufacturer's specifications.
3. The cost for the labor and parts required to return the Radio Shack computer equipment to original manufacturer's specifications will be charged to the customer in addition to the normal repair charge.

TERMS AND CONDITIONS OF SALE AND LICENSE OF RADIO SHACK COMPUTER EQUIPMENT AND SOFTWARE
PURCHASED FROM A RADIO SHACK COMPANY-OWNED COMPUTER CENTER, RETAIL STORE OR FROM A
RADIO SHACK FRANCHISEE OR DEALER AT ITS AUTHORIZED LOCATION

LIMITED WARRANTY

I. CUSTOMER OBLIGATIONS

- A. CUSTOMER assumes full responsibility that this Radio Shack computer hardware purchased (the Equipment) and any copies of Radio Shack software included with the Equipment or licensed separately (the Software) meets the specifications, capacity, capabilities, versatility, and other requirements of CUSTOMER.
- B. CUSTOMER assumes full responsibility for the condition and effectiveness of the operating environment in which the Equipment and Software are to function, and for its installation.

II. RADIO SHACK LIMITED WARRANTIES AND CONDITIONS OF SALE

- A. For a period of ninety (90) calendar days from the date of the Radio Shack sales document received upon purchase of the Equipment, RADIO SHACK warrants to the original CUSTOMER that the Equipment and the medium upon which the Software is stored is free from manufacturing defects. THIS WARRANTY IS ONLY APPLICABLE TO PURCHASES OF RADIO SHACK EQUIPMENT BY THE ORIGINAL CUSTOMER FROM RADIO SHACK COMPANY-OWNED COMPUTER CENTERS, RETAIL STORES AND FROM RADIO SHACK FRANCHISEES AND DEALERS AT ITS AUTHORIZED LOCATION. The warranty is void if the Equipment's case or cabinet has been opened, or if the Equipment or Software has been subjected to improper or abnormal use. If a manufacturing defect is discovered during the stated warranty period, the defective Equipment must be returned to a Radio Shack Computer Center, a Radio Shack retail store, participating Radio Shack franchisee or Radio Shack dealer for repair, along with a copy of the sales document or lease agreement. The original CUSTOMER'S sole and exclusive remedy in the event of a defect is limited to the correction of the defect by repair, replacement, or refund of the purchase price, at RADIO SHACK'S election and sole expense. RADIO SHACK has no obligation to replace or repair expendable items.
- B. RADIO SHACK makes no warranty as to the design, capability, capacity, or suitability for use of the Software, except as provided in this paragraph. Software is licensed on an "AS IS" basis, without warranty. The original CUSTOMER'S exclusive remedy, in the event of a Software manufacturing defect, is its repair or replacement within thirty (30) calendar days of the date of the Radio Shack sales document received upon license of the Software. The defective Software shall be returned to a Radio Shack Computer Center, a Radio Shack retail store, participating Radio Shack franchisee or Radio Shack dealer along with the sales document.
- C. Except as provided herein, no employee, agent, franchisee, dealer, or other person is authorized to give any warranties of any nature on behalf of RADIO SHACK.
- D. Except as provided herein, **RADIO SHACK MAKES NO WARRANTIES, INCLUDING WARRANTIES OF MERCHANTABILITY OR FITNESS FOR A PARTICULAR PURPOSE.**
- E. Some states do not allow limitations on how long an implied warranty lasts, so the above limitation(s) may not apply to CUSTOMER.

III. LIMITATION OF LIABILITY

- A. EXCEPT AS PROVIDED HEREIN, RADIO SHACK SHALL HAVE NO LIABILITY OR RESPONSIBILITY TO CUSTOMER OR ANY OTHER PERSON OR ENTITY WITH RESPECT TO ANY LIABILITY, LOSS OR DAMAGE CAUSED OR ALLEGED TO BE CAUSED DIRECTLY OR INDIRECTLY BY EQUIPMENT OR SOFTWARE SOLD, LEASED, LICENSED OR FURNISHED BY RADIO SHACK, INCLUDING, BUT NOT LIMITED TO, ANY INTERRUPTION OF SERVICE, LOSS OF BUSINESS OR ANTICIPATORY PROFITS OR CONSEQUENTIAL DAMAGES RESULTING FROM THE USE OR OPERATION OF THE EQUIPMENT OR SOFTWARE. IN NO EVENT SHALL RADIO SHACK BE LIABLE FOR LOSS OF PROFITS OR ANY INDIRECT, SPECIAL, OR CONSEQUENTIAL DAMAGES ARISING OUT OF ANY BREACH OF THIS WARRANTY OR IN ANY MANNER ARISING OUT OF OR CONNECTED WITH THE SALE, LEASE, LICENSE, USE OR ANTICIPATED USE OF THE EQUIPMENT OR SOFTWARE.

NOTWITHSTANDING THE ABOVE LIMITATIONS AND WARRANTIES, RADIO SHACK'S LIABILITY HEREUNDER FOR DAMAGES INCURRED BY CUSTOMER OR OTHERS SHALL NOT EXCEED THE AMOUNT PAID BY CUSTOMER FOR THE PARTICULAR EQUIPMENT OR SOFTWARE INVOLVED.
- B. RADIO SHACK shall not be liable for any damages caused by delay in delivering or furnishing Equipment and/or Software.
- C. No action arising out of any claimed breach of this Warranty or transactions under this Warranty may be brought more than two (2) years after the cause of action has accrued or more than four (4) years after the date of the Radio Shack sales document for the Equipment or Software, whichever first occurs.
- D. Some states do not allow the limitation or exclusion of incidental or consequential damages, so the above limitation(s) or exclusion(s) may not apply to CUSTOMER.

IV. RADIO SHACK SOFTWARE LICENSE

RADIO SHACK grants to CUSTOMER a non-exclusive, paid-up license to use the RADIO SHACK Software on **one** computer, subject to the following provisions:

- A. Except as otherwise provided in this Software License, applicable copyright laws shall apply to the Software.
- B. Title to the medium on which the Software is recorded (cassette and/or diskette) or stored (ROM) is transferred to CUSTOMER, but not title to the Software.
- C. CUSTOMER may use Software on one host computer and access that Software through one or more terminals if the Software permits this function.
- D. CUSTOMER shall not use, make, manufacture, or reproduce copies of Software except for use on **one** computer and as is specifically provided in this Software License. Customer is expressly prohibited from disassembling the Software.
- E. CUSTOMER is permitted to make additional copies of the Software **only** for backup or archival purposes or if additional copies are required in the operation of **one** computer with the Software, but only to the extent the Software allows a backup copy to be made. However, for TRSDOS Software, CUSTOMER is permitted to make a limited number of additional copies for CUSTOMER'S own use.
- F. CUSTOMER may resell or distribute unmodified copies of the Software provided CUSTOMER has purchased one copy of the Software for each one sold or distributed. The provisions of this Software License shall also be applicable to third parties receiving copies of the Software from CUSTOMER.
- G. All copyright notices shall be retained on all copies of the Software.

V. APPLICABILITY OF WARRANTY

- A. The terms and conditions of this Warranty are applicable as between RADIO SHACK and CUSTOMER to either a sale of the Equipment and/or Software License to CUSTOMER or to a transaction whereby RADIO SHACK sells or conveys such Equipment to a third party for lease to CUSTOMER.
- B. The limitations of liability and Warranty provisions herein shall inure to the benefit of RADIO SHACK, the author, owner and/or licensor of the Software and any manufacturer of the Equipment sold by RADIO SHACK.

VI. STATE LAW RIGHTS

The warranties granted herein give the **original** CUSTOMER specific legal rights, and the **original** CUSTOMER may have other rights which vary from state to state.

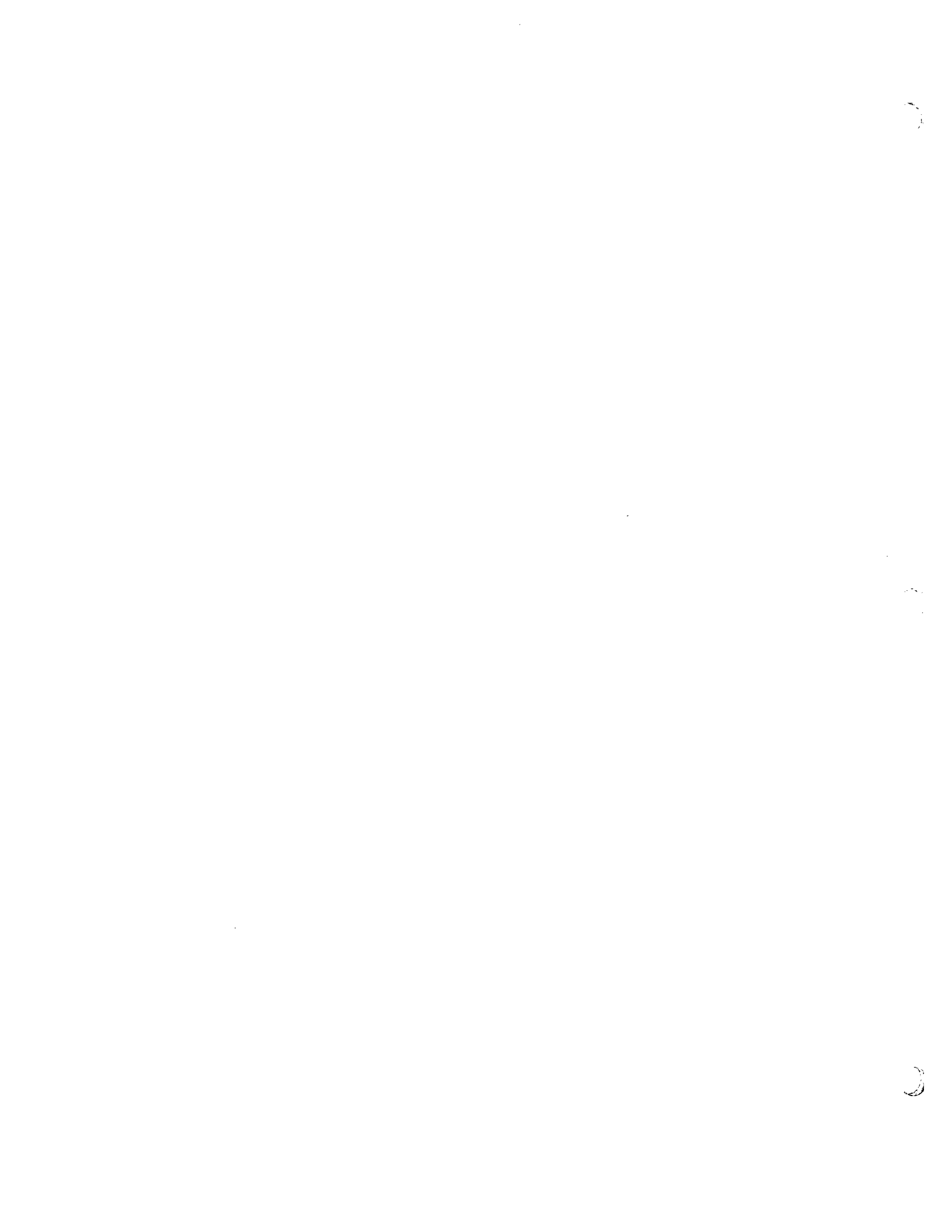

Contents

Introduction	1
1/ Description of the DMP-120	3
2/ Setting Up the DMP-120	7
Tractor Installation and Removal	7
How Does the DMP-120 Handle Paper?	9
Paper Loading	9
Single-Sheet Paper Loading	9
Roll Paper Loading	10
Fanfold Paper Loading	12
Ribbon Installation/Replacement.....	13
Setting Print Function Switches (DIP Switches)	14
Connecting the DMP-120 to a Power Source	16
Carriage Movement Test	16
Self-Test	16
Connecting the DMP-120 to the TRS-80	17
Power-Up Sequence	17
3/ Using the DMP-120 (General Printer Operation)	19
Control Codes	19
Sending Control Codes from BASIC.....	20
Character Printing Mode	20
Graphics Mode	21
Selecting a Print Mode	21
4/ Print Font Styles and Character Widths	23
Selecting Font Styles	23
Standard Character Font Style.....	24
Graphic Characters	25
Wrap-Around	25
Elongated Characters.....	26
5/ General Control Codes	27
Line Feed Codes (LF)	27
Special Line Feed Control Codes.....	27
Carriage Return (CR).....	28
Ignored or Undefined Codes.....	28
DMP-120 Buffer Operation	29
6/ Graphics Mode.....	31
Printing Graphic Patterns	31
Line Feed	32
Print Density	32
Leaving Graphics Mode.....	32
Mixing Modes on the Same Line	32
Freehand Drawings	32

Appendix A/ Control Code Summary	35
Appendix B/ Interfacing	37
Appendix C/ Character Sets	41
Appendix D/ Programming Information.....	45
Appendix E/ Care and Maintenance.....	47
Appendix F/ Schematic Diagram	49
Appendix G/ Specifications.....	51

1/ Description of the DMP-120

Carefully unpack the DMP-120, being sure to locate the Ribbon Cassette. Keep the empty box and packing material just in case you ever need to transport the Printer.

Be sure to remove the protective black plastic tube from the rear Carriage Guide. Also remove the white plastic clips that keep the Tractor Unit in place.

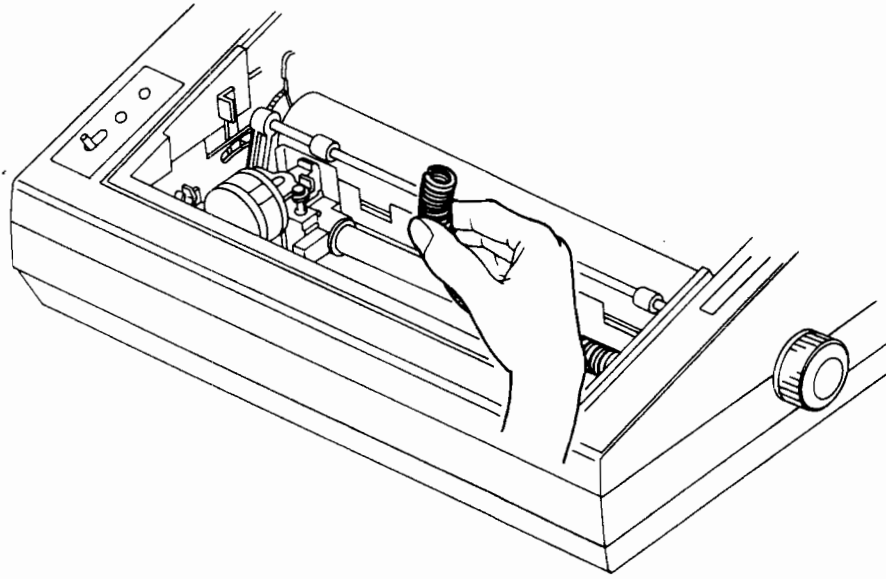

Figure 1. Removing the Black Tube

Locate the paper guide packed separately. Install it in the metal hole under paper guide cover.

It's important to become familiar with the DMP-120 before you set it up and begin using it.

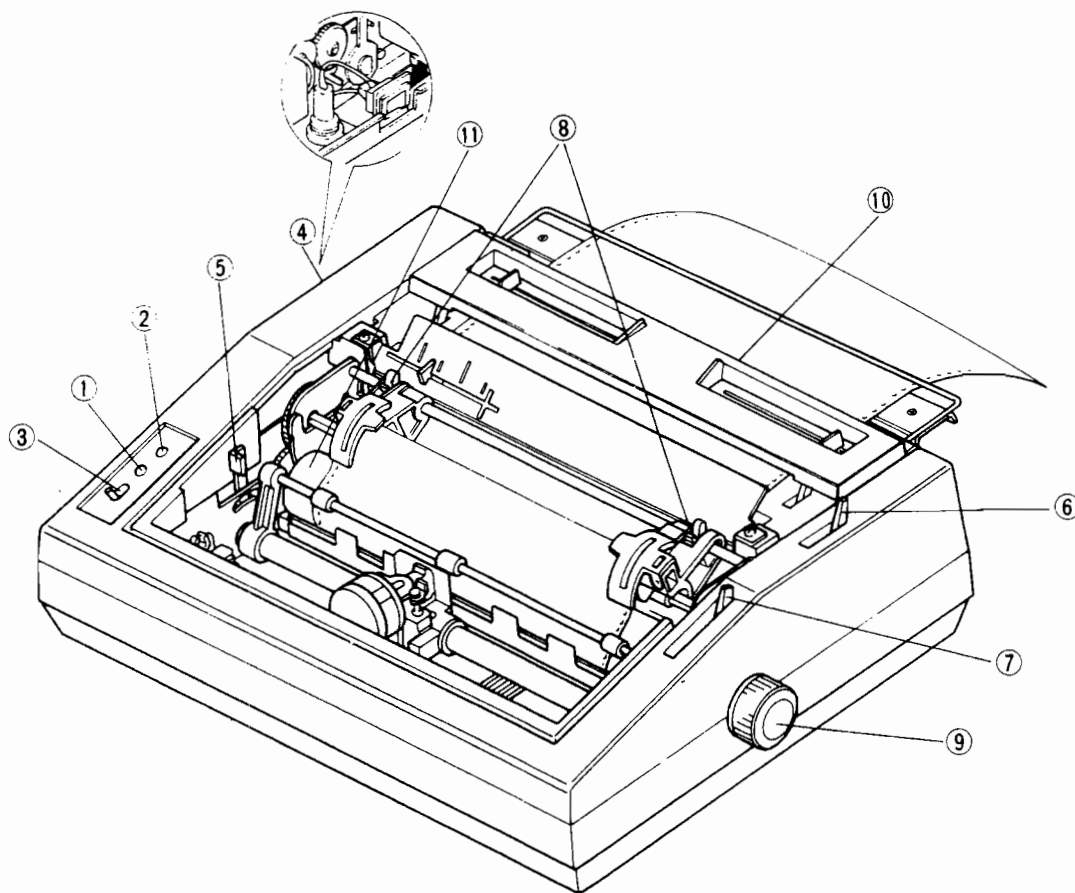

Figure 2. DMP-120 (Top View)

- ① **ALERT Indicator.** This lamp will come on when the Printer is out of paper, or when there is a carriage fault.
- ② **POWER ON Indicator.** The indicator will illuminate when the DMP-120 is properly connected and the Power ON/OFF Switch is set to ON.
- ③ **ON-LINE/OFF-LINE Switch.** This switch must be set to ON-LINE before the DMP-120 will print. To stop printing at anytime, set this switch to OFF-LINE.

When the Printer stops because it is out of paper, the ALERT lamp will illuminate and the Printer automatically goes OFF-LINE. To continue printing, insert more paper, set the ON-LINE/OFF-LINE switch to OFF-LINE, and then to ON-LINE. The DMP-120 will then return to ON-LINE (and continue printing without loss of data in the print buffer).

Model II users: If a BASIC program stops execution because of a Printer error, typing: `CONT` **(ENTER)** will cause printing to resume. However the entire contents of the print buffer will be printed starting with the current Print Head position.

- ④ **Power ON/OFF Switch.** Press the white dot to turn the power ON. Press the Switch the other way to turn power OFF. Note that turning the power OFF and ON during operation may cause loss of the current program.
- ⑤ **Print Head Adjustment Lever.** Move this Lever toward you (i.e., move the Print Head away from the paper) when changing ribbons. If printing is faint, move the Lever away from you (i.e., the Print Head toward the paper); if smudging occurs during printing, move the Print Head one or two notches away from the paper.
- ⑥ **Platen Pressure Lever.** If you are "friction feeding" paper, set this lever to the rear (and pressure will be ON). If you're "tractor feeding" paper, set this lever to the front (and pressure will be OFF).
- ⑦ **Paper Bail Lever.** With tractor feed or friction feed, move the Paper Bail onto the paper to obtain improved print quality.
- ⑧ **Tractor Feed.** This Tractor Feed is removable. See "Setting Up the DMP-120" for details on using the Tractor Feed. You can remove the Tractor when printing on single-sheet paper.
- ⑨ **Paper Feed Knob.** Turn this Knob to manually advance the paper.
- ⑩ **Paper Insertion Opening.** Be sure the paper enters the DMP-120 here.
- ⑪ **Platen.**

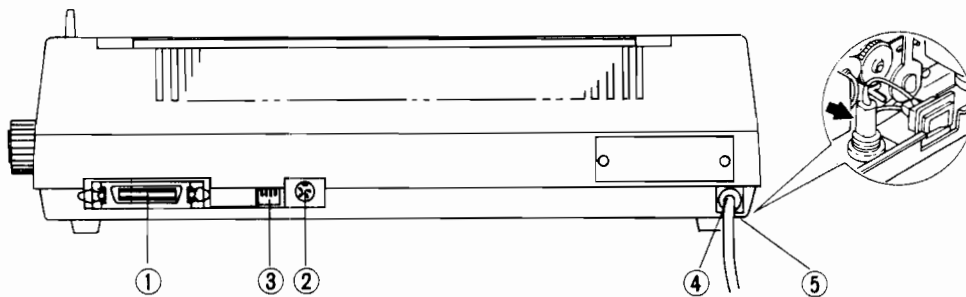
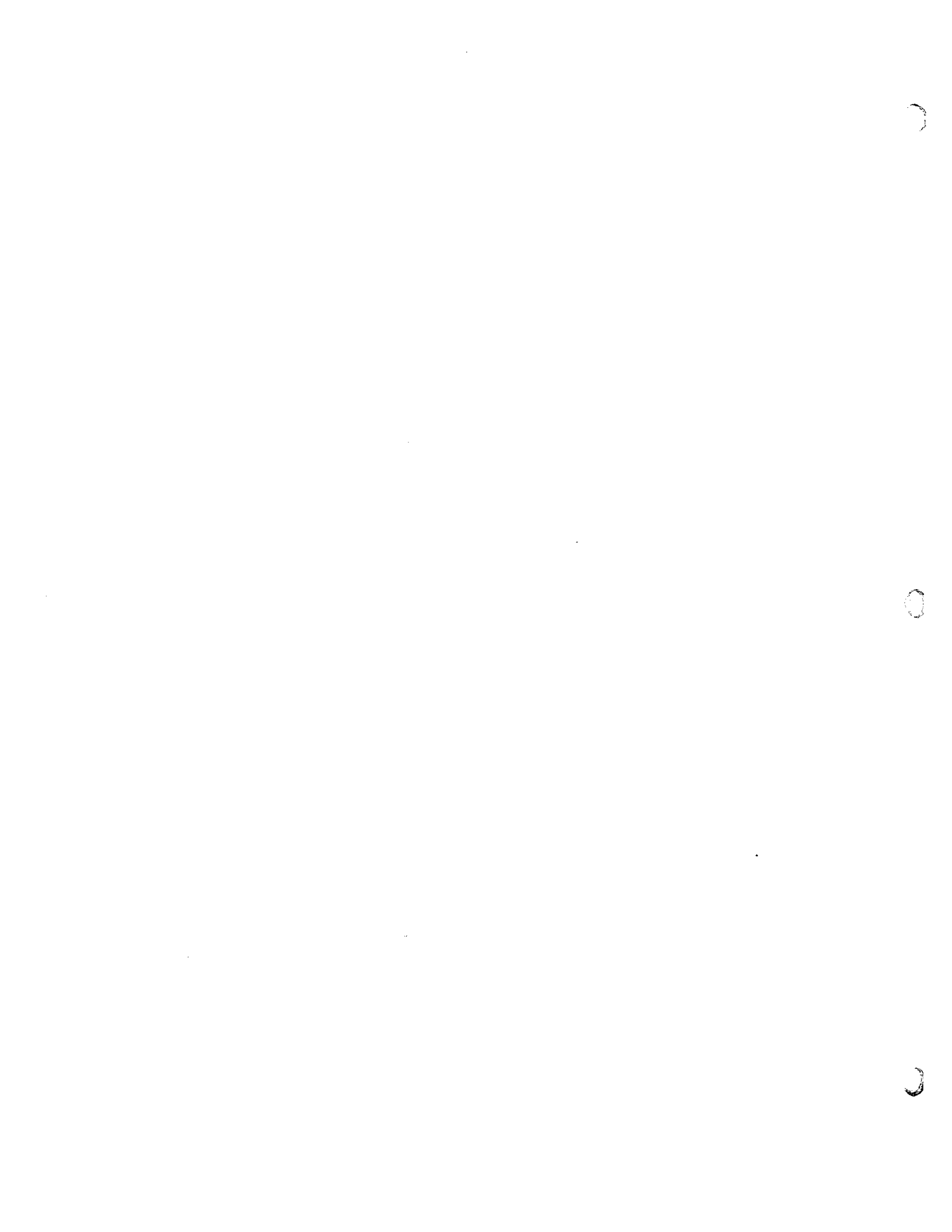

Figure 3. DMP-120 (Rear View)

- ① **Parallel Interface Connector.** If your TRS-80 has parallel interface capabilities, connect the cable here. See "Setting Up the DMP-120" for the right cable for your TRS-80.
- ② **Serial Interface Connector.** If your TRS-80 has serial interface capabilities, connect the cable here. See "Setting Up the DMP-120" for the right cable for your TRS-80.
- ③ **Print Function (DIP) Switch.** The settings of this Switch will determine exactly how your Printer prints in any situation. Such parameters as baud rate (600 or 1200 baud) or whether you're using the serial or parallel interface must be set via this Switch.
- ④ **Power Cord.** Plug the power cord into a wall-outlet or approved power strip.
- ⑤ **Fuse Holder** (on the bottom of the cabinet)



2/ Setting Up the DMP-120

This section will show you how to set up the DMP-120 so you can begin using it as quickly as possible. This includes:

- Installing the Tractor Feed.
- Loading paper.
- Replacing a ribbon.
- Connecting the DMP-120 to a TRS-80

and more!

The following **Start-Up Checklist** is a summary of how to set up your Printer. You should follow this procedure *every time* you start up the Printer — not just the first time.

- Find a good spot for your Printer. Be sure to consider:
 - The Printer should be placed on a sturdy work surface.
 - The length of the printer cable will determine how far from the TRS-80 you can place the Printer.
 - Paper takes up space. Be sure to leave enough room for smooth paper flow.
 - Don't place the Printer near noise generators such as refrigerators and industrial equipment.
- Be sure the POWER switch (at left side of Printer) is OFF.
- Remove the Top Cover and the packing materials, including the black plastic cover on the carriage guide.
- Install continuous form fanfold paper or single-sheet paper.
- Check the Ribbon Cassette. If it has not been installed, see **Ribbon Installation/Replacement**.
- Set Print Function (DIP) Switches (rear of Printer).
- Connect the AC power plug to a 3-wire, 120-volt, 60-Hz grounded AC outlet (220/240 V, 50 Hz where the unit is so marked).
- Connect the interface cable from the TRS-80 to the printer interface connector.
- Turn the Power ON and check that the Power On indicator (on the Front Panel) is illuminated.
- Check that the Printer is ready by running the Self-Test.
- Place ON-LINE/OFF-LINE Switch in ON-LINE position.

Tractor Installation and Removal

This Printer can be used with either the Tractor Feed system or the Friction Feed system. The difference is that the Tractor Feed system is used with paper which has guide holes on both edges while the paper used with the Friction Feed system does not have these holes.

The Friction Feed system may be used with the tractor installed; however, more efficient operation can be achieved if it is removed, especially with single sheets of paper.

Removing the Tractor

1. Set the Power Switch to OFF and remove the Top Cover.
2. Hold the Tractor on both ends and pull up on the rear of the Tractor to disengage it from the Printer.
3. Replace the Top Cover.

Installing the Tractor

1. Set the Power Switch to OFF and remove the Top Cover.
2. Insert the claw slots (on the lower front sides of the Tractor) onto the Printer studs (see Figure 4).
3. Rock the Tractor Unit back until it snaps into place.
4. Turn the Paper Feed Knob to verify that the sprockets rotate.
5. Replace the Top Cover.

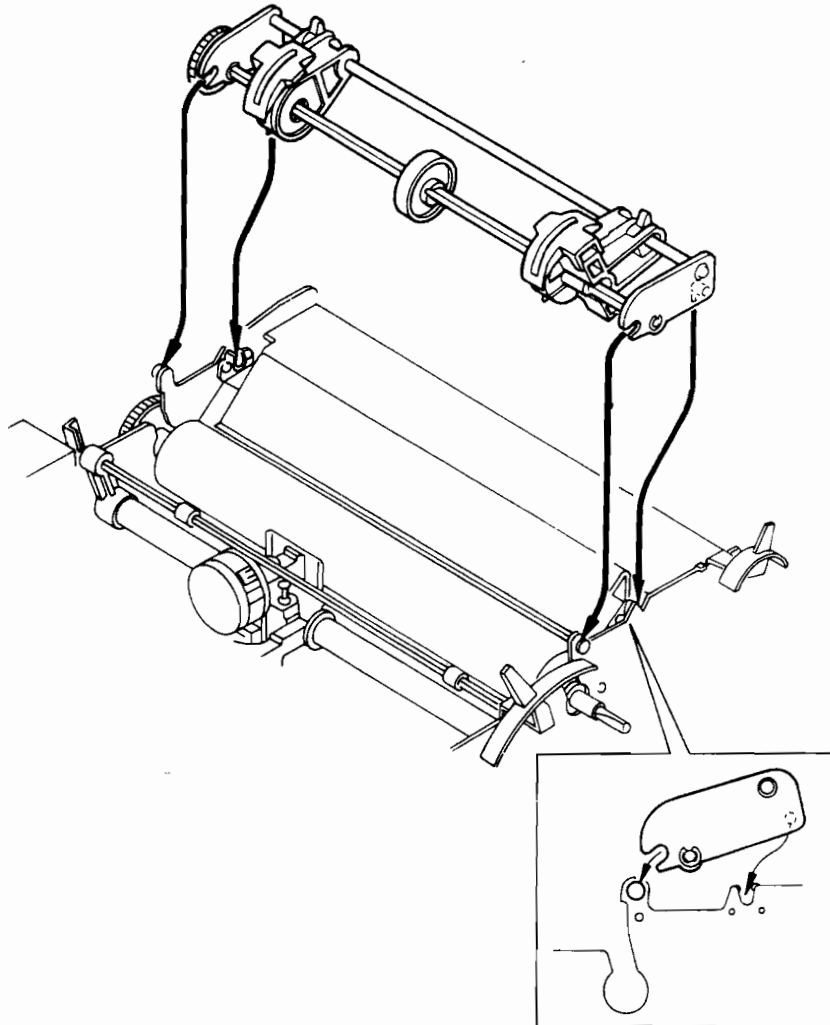

Figure 4 Installing the Tractor

How Does the DMP-120 Handle Paper?

The DMP-120 provides both Tractor Feed for continuous forms and Friction Feed for single-sheet and roll paper printing. The Friction Feed system may be used with the Tractor installed; however, better efficiency can be achieved if it is removed.

Paper Loading

Warning! When loading paper (single-sheets, fanfold, or roll paper), be sure the paper correctly enters the Paper Insertion Opening (See Figure 5).

If the paper is correctly loaded, it should *enter between the body of the Printer and the Paper Guide*. Once the paper is loaded and power is ON, check the ALERT Indicator. If the lamp is illuminated, turn the ON-LINE/OFF-LINE switch to ON-LINE. If the lamp remains on, the paper is probably loaded incorrectly.

If the lamp is not illuminated after the paper is loaded, you may begin printing (if the power is ON).

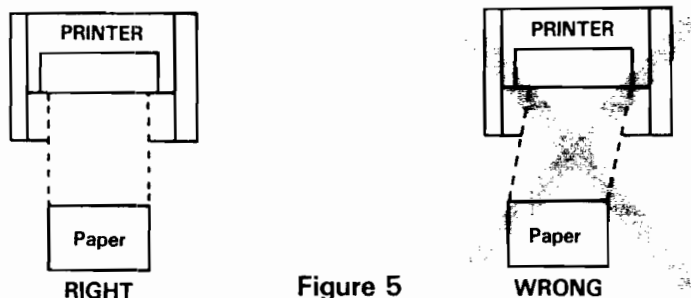

Single-Sheet Paper Loading

1. Be sure the Power Switch is OFF.
2. Remove the Top Cover.
3. Gently move the Print Head Adjustment Lever away from the paper.
4. Move the Platen Pressure Lever and the Paper Bail Lever forward (toward the front of the Printer).
5. Insert the paper into the Paper Insertion Opening and push the Release Lever back toward the rear of the Printer. Use the Paper Feed Knob to pull the paper around until it appears between the Platen and the Print Head (See Figure 6).
6. Move the Release Lever forward to align the paper. Push the Release Lever back again.
7. Set the Print Head Adjustment Lever to the appropriate position.
 - Single-Part Forms. Move the Lever toward the paper as far as it will go.
 - Multiple-part Forms. Move the Lever as far as it will go toward the Platen without smudging the paper. Check for smudging by moving the Carriage back and forth at each of the Lever settings.

Warning! *The Print Head Adjustment Lever must always be as close to the Platen as possible; otherwise damage to the Print Head may result.*

8. Move the Paper Bail Lever toward the paper.
9. Replace the Top Cover.

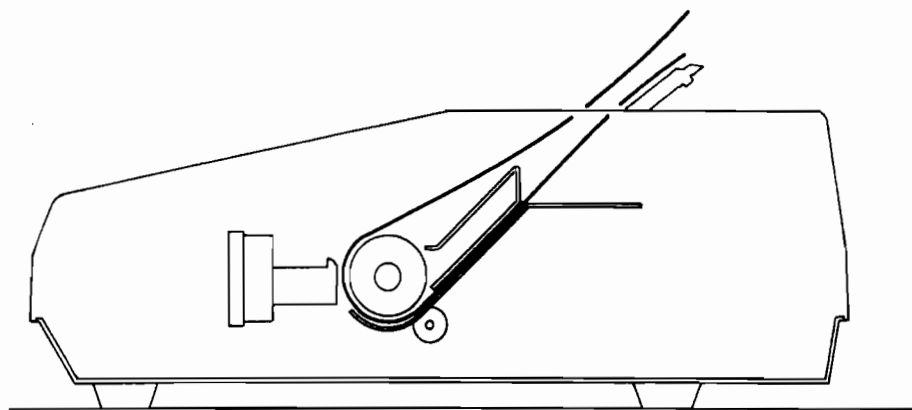

Figure 6 Single-Sheet Paper Feeding

Hints and Tips On Single-Sheet Paper Loading.....

- Remember to set the Platen Pressure Lever and the Paper Bail Lever to the rear of the Printer while using single-sheet paper.

Roll Paper Loading

1. Set the Power ON/OFF Switch to OFF.
2. Be sure there is enough space on a flat, wide surface behind the Printer for the Roll Paper Holder.
3. Remove the Paper Guides. Insert both support arms of the Paper Holder into the slot in the top rear of the Printer and place the other end of the Holder on the flat surface. Be sure the Paper Guides on the Printer are inside the support arms.
4. Insert the Roll Paper Shaft through the standard 1" roll paper core and put the core hub through the shaft. Place the paper/shaft onto the holder so that the paper feeds from the bottom of the roll (see Figure 7).
5. Remove the Paper Guide Cover.
6. Remove the Top Cover.
7. Gently pull the Print Head Control Lever away from the Platen.
8. Gently pull the Platen Release Lever and the Paper Bail Lever forward (toward the front of the Printer).
9. Insert the paper into the paper insertion opening and push the Release Lever back toward the rear of the Printer. Turn the Paper Feed Knob until the paper appears between the Platen and the Paper Bail.
10. Tilt the Paper Bail Lever toward the rear of the Printer.
11. Move the Print Head Control Lever completely toward the Platen to provide maximum Print Head penetration.

Warning! The Print Head Control Lever must always be as close to the Platen as possible; otherwise damage to the Print Head may occur.
12. Replace the Top Cover.
13. Adjust the Paper Guides on the top rear so that there is a very small space between the guides and the edge of the paper.
14. Replace the Paper Guide Cover.

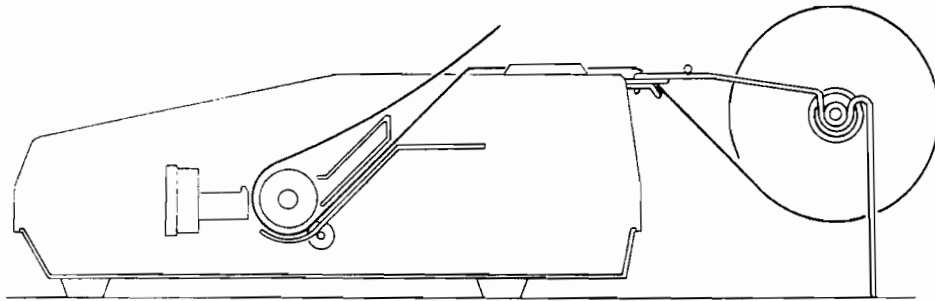

Figure 7 Roll Paper Feed

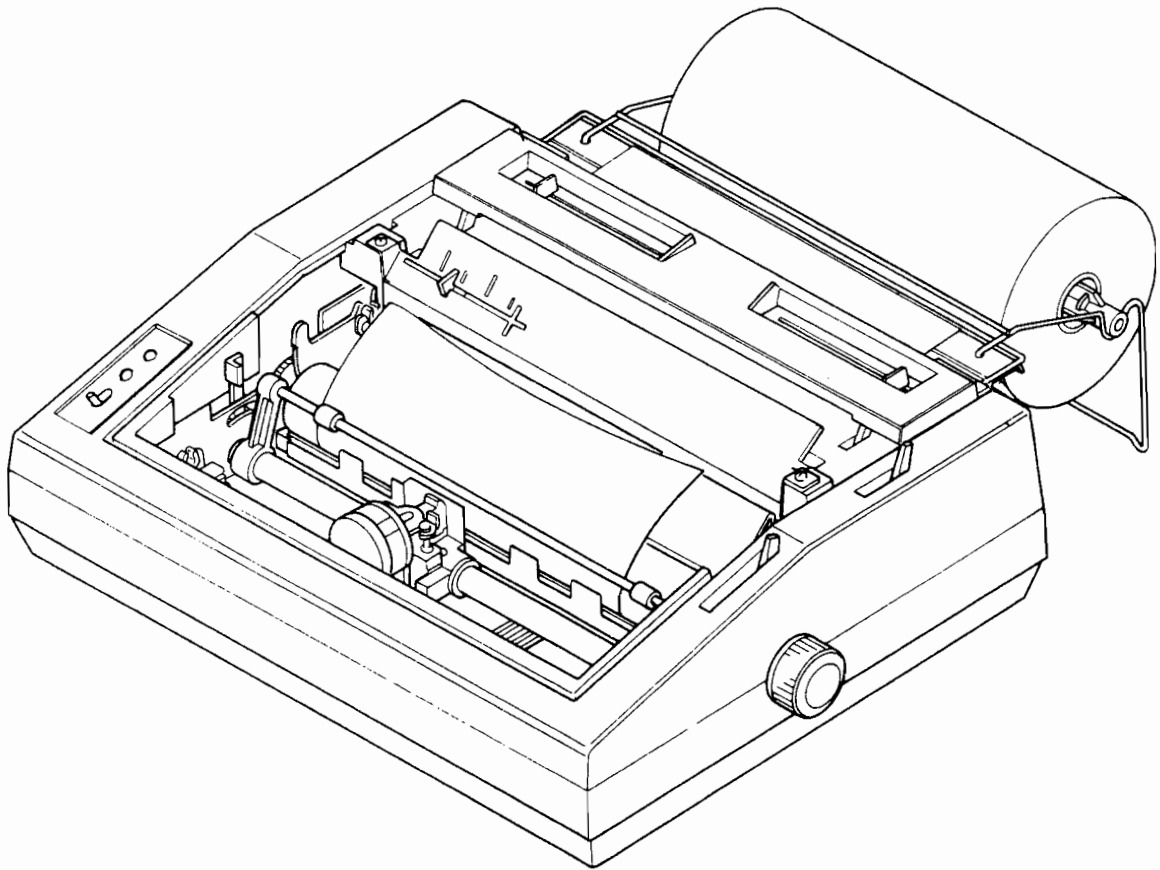

Figure 8 Roll Paper Installation

Fanfold Paper Loading

The DMP-120 will accept standard fanfold paper that is from 4" to 10" wide. The paper may contain one original and up to two copies.

Before using fanfold paper, however, the Tractor Feed should be installed.

To load fanfold paper into the DMP-120:

1. Set the Power ON/OFF Switch to OFF.
 2. Remove the Top Cover.
 3. Move the Print Head Control Lever away from the paper.
 4. Gently move the Platen Pressure Lever and the Paper Bail Lever toward the front of the Printer.
 5. Pass the paper through the Paper Insertion Opening. Return the Release Lever and turn the Paper Feed Knob to advance the paper.
 6. Move the Release Lever toward the front once again and pull out approximately 6" of paper.
 7. Raise the clamps on the Paper Feed Sprocket Units. Align the paper guide holes with the sprockets and snap the clamps back onto the sprockets.
 - If the paper guide holes do not fit over the sprockets, release the lever on the Sprocket Units, re-position the Unit, then snap the lever closed. If the paper is stretched too tightly or is loose and wrinkled, it may not feed through correctly.
 - Be sure that the paper is straight (i.e., even across the top of page) when it is clamped on the sprockets.
 8. Set the Penetration Control Lever as follows:
 - **Single-Part Forms.** Move the Lever toward the paper as far as it will go.
 - **Multiple-Part Forms.** Move the Lever as far as it will go toward the Platen without smudging the paper. Check for smudging by moving the Carriage back and forth at each of the Lever settings.
- Warning! The Print Head Control Lever must always be as close to the Platen as possible; otherwise, damage to the Print Head may result.*
9. Move the Paper Bail Lever toward the paper.
 10. Replace the Top Cover.

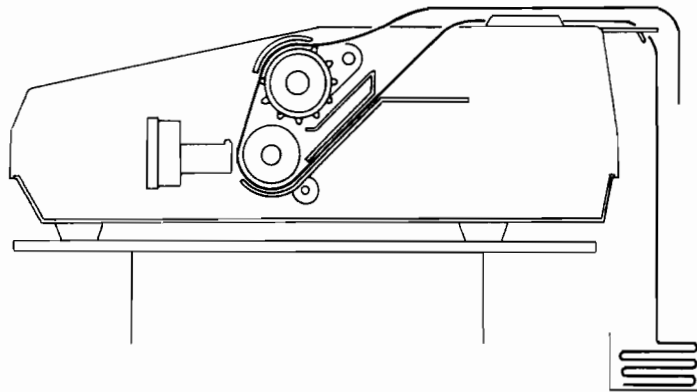

Figure 9 Fanfold Paper Feed (Rear Feed)

Hints and Tips On Fanfold Paper Loading.....

- Whenever the Tractor feed is used, the Platen Pressure Lever must be toward the front of the Printer. For friction feed paper, set the Lever to the rear of the Printer to apply pressure to the paper.
- Remember to set the Platen Pressure Lever and the Paper Bail Lever to the rear of the Printer while using fanfold paper.
- Be sure that the paper is positioned so that it can travel through the Printer without binding.
- *Do not let paper* pile up on top of unprinted paper or printed paper may be pulled back into the Paper Insertion Opening. This could jam the paper feed or damage the Printer.

Ribbon Installation/Replacement

If the Ribbon Cassette is already installed, simply check to see that it is properly threaded between the paper and Print Head.

If the Ribbon Cassette is not installed, or if it must be replaced due to excessive wear, faint printing, etc., follow this procedure:

1. Set the Power switch to OFF. (**Note:** When you turn the power OFF, any information stored in the Printer's buffer will automatically be lost.)
2. Remove the Top Cover and move the Print Head Control Lever toward the front of the Printer as far as it will go. *Gently* move the Print Head *toward the center* of the Platen.
3. Gently grasp the Ribbon Cassette by the edges nearest the Platen and lift it upward.
4. Unwrap the new Cassette and remove the packing foam.

Before inserting the new Cassette, tighten the Ribbon by turning the Knob in the direction indicated by the arrow.

5. Gently press the Cassette down until it is firmly secured by the "stopper claws."

Do not force the Cassette into place! If the Cassette is not properly fitted, the Cassette knob will not match up with the shaft from the Carriage. Do not force the Cassette down but fit it in gradually while turning the Cassette knob in the indicated direction.

6. Once the new Cassette is installed, *gently slide the ribbon in between the paper and the Print Head*. Tighten the ribbon by turning the Cassette knob in the indicated direction.
7. Move the Carriage back and forth manually to check that the ribbon advances properly. If the ribbon has not been properly fitted between the paper and Print Head (i.e., into the Print Head Ribbon Guide Bezel), the Ribbon feed will not operate smoothly (see Figure 10).
8. Move the Print Head Control Lever toward the rear of the Printer.
9. Replace the Top Cover.

Remember! *It is extremely important that the Print Head is as close to the paper as possible; otherwise, damage to the Print Head may occur. Simply move the Print Head Control Lever toward the paper and move the Carriage back and forth until smudging occurs. Then gradually move the Control Lever away from the paper until the smudging stops.*

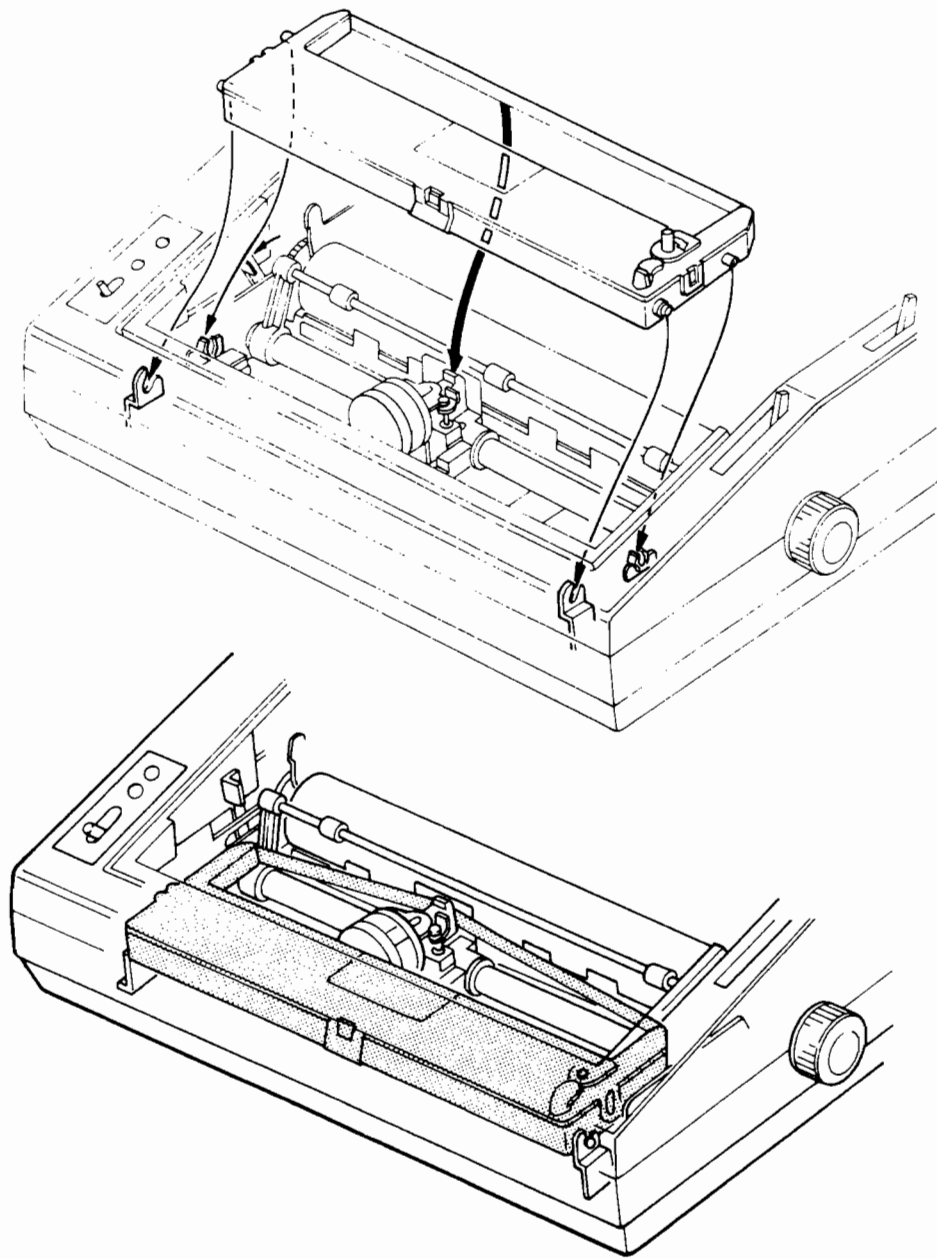

Figure 10 Ribbon Cassette Installation

Setting Print Function Switches (DIP Switches)

There are four switches located at the right rear of the Printer. These Switches allow you to customize some of the DMP-120 features for your own applications.

When you receive the DMP-120, all switches should be set to OFF (i.e., in the down position). By setting certain switches ON, *before turning the DMP-120's power ON*, you can select different baud rates, interface modes, etc. Figure 11 defines the different switch positions and settings.

Remember! The Printer power must be OFF before you change any of the Switches.

Pos.	Symbol	OFF	ON
1	NL/CR	CR code generates "CR+LF" operation.	CR code causes only Carriage Return operation.
2	NORMAL TEST	Normal Operation is activated.	Self Test pattern is generated automatically.
3	1200 BPS 600 BPS	When the Serial Interface is available, transmission rate is set to 1200 BPS.	When the Serial Interface is available, transmission rate is set to 600 BPS.
4	Parallel Serial	Parallel Interface is available.	Serial Interface is available.

Table 1

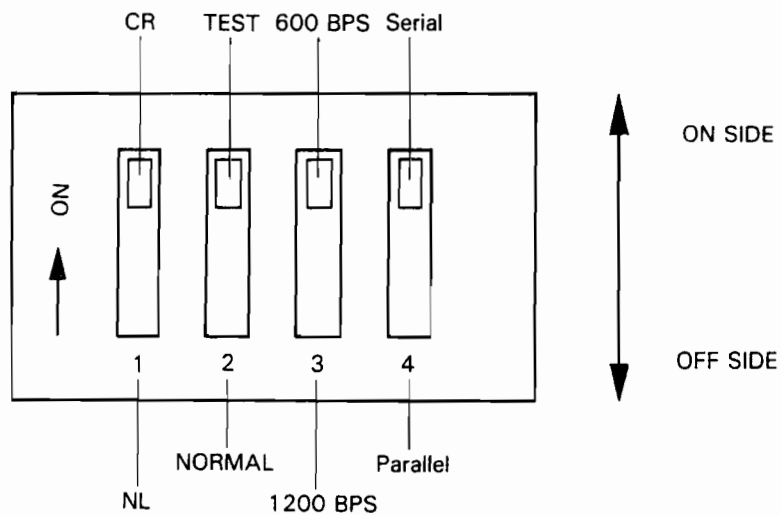

Figure 11 Print Function (DIP) Switches

Connecting the DMP-120 to a Power Source

Before plugging the power cord into an AC power outlet, check the following:

- Is Printer Power ON/OFF Switch set to OFF?
- Have you removed the black plastic protective tube from the Carriage Guide?
- Don't connect the Printer to the Computer yet.

Connect the AC power plug to a 3-wire, 120-volt, 60-Hz grounded AC outlet (220/240 V, 50 Hz where the unit is so marked) or an approved power strip such as the Radio Shack Plug-in Power Strip (61-2619) or the Automatic Power Controller, SW-301 (26-1429).

Carriage Movement Test

The Carriage Movement Test allows you to check that the Carriage moves freely from one end of the Platen to the other and that the Platen is turning properly.

Printing is not performed during the Carriage Movement Test.

1. Set the ON-LINE/OFF-LINE switch to ON-LINE and then set the Power Switch to ON. The Carriage will then move right and left performing a Line Feed at the end of each line.
2. Turn the power OFF to end the Carriage Movement Test.

Self-Test

The DMP-120 has a "built-in" self-test feature which lets you check printing quality and general printer operation before you connect the Printer to a TRS-80. This is a good time to check that the Print Head is adjusted properly (printing is neither too faint nor smudging) and paper is feeding properly.

The Self-Test will last for several minutes. It includes the various printer font styles, print widths and intensities, and even a dot graphics sample.

As test printing is 8" in width, always be sure to load the printer with paper to cover this before running the Self-Test. **Printing on the Platen can shorten the life of the Platen and Print Head.**

To run the Self-Test:

1. Set Print Function Switch 2 to ON (the up position)
2. Set the ON-LINE/OFF-LINE Switch to OFF-LINE.
3. Turn Power ON.

The Printer will begin printing all the characters that it's capable of printing.

4. Printing will continue until you turn the power OFF.

Connecting the DMP-120 to the TRS-80

Before making any connections between the Printer and TRS-80, be sure all units are off!

You must also be sure you have the correct cable for your TRS-80 if the DMP-120 is to operate properly. Table 2 describes the printer cables Radio Shack provides; Table 3 provides quick instructions for printer connection locations.

1. Attach the molded male end of the cable to the connector on the left rear side of the Printer.
Do not force the plug. If it doesn't fit one way, turn it over and try again.
2. Connect the other end of the cable to the Printer Jack of your Computer. See your TRS-80 owner's manual for specific instructions.

TRS-80 to DMP-120 Cables

TRS-80	Cable Number
Model I (Keyboard only)	26-1411
Model I (Exp. Interface)	26-1401
Model II/16/DT-1	26-4401
Model III	26-1401
Color Computer	26-3020

Table 2

TRS-80 Connection Points

TRS-80	Connector
Model I (Keyboard only)	Rear of Keyboard
Model I (Exp. Interface)	Left side of E.I.
Model II/16	Rear Panel of Computer
Model III/DT-1	Underneath panel
Color Computer	Rear Panel of Computer

Table 3

Power-Up Sequence

The specific power-up sequence will depend upon your Computer. We suggest you consult your TRS-80 owner's manual for details on powering up your TRS-80 with peripheral devices (such as printers).

In any event, the Power Lamp will remain lit while the Printer is ON.

It is essential that the Printer remain ON when connected to the Computer. If you turn the power ON or OFF, or a Printer is connected but not turned on, erratic operation of the entire system may occur.

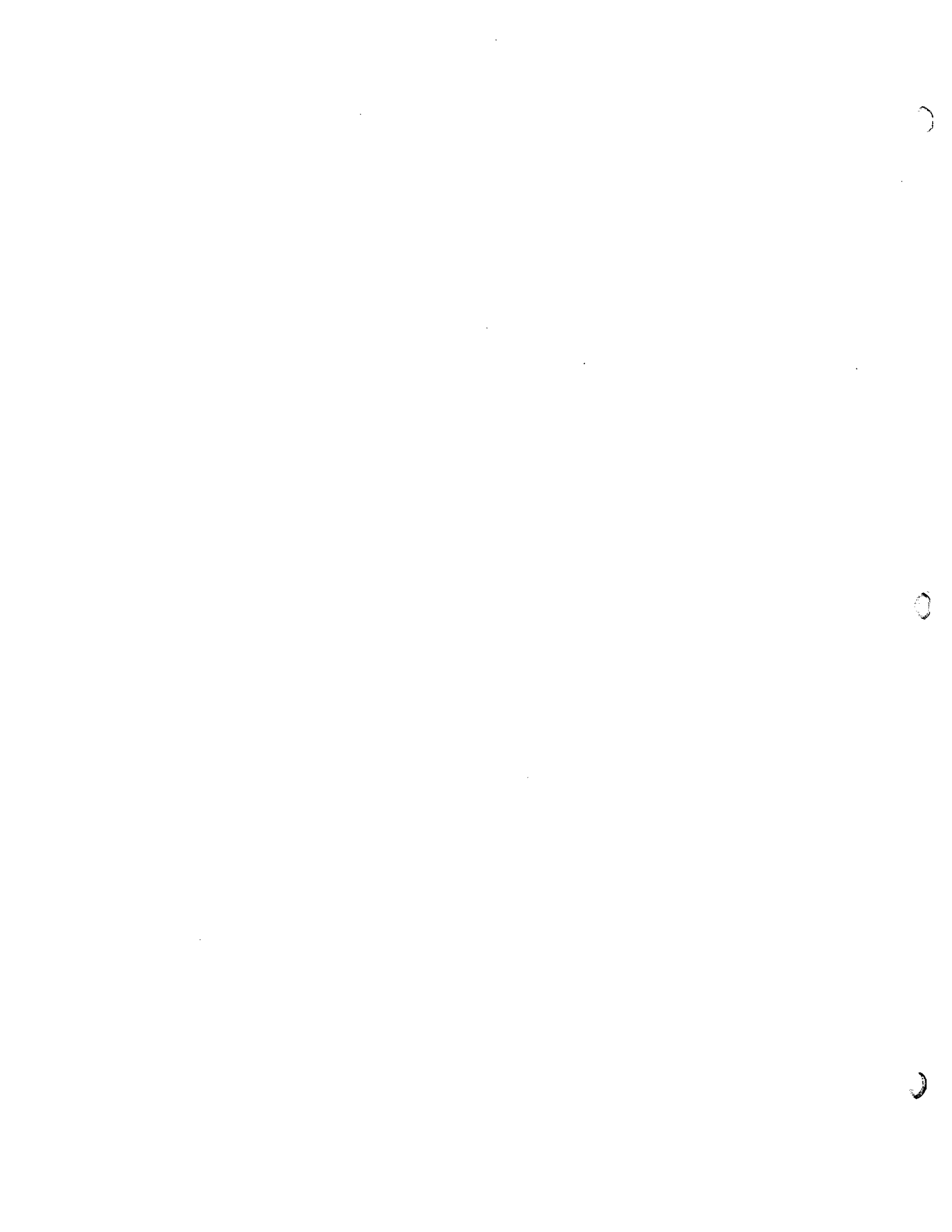

3/ Using the DMP-120 (General Printer Operation)

The DMP-120 is designed for two distinct applications:

- Character Printing
- Graphics Printing

The Printer responds to software in two different ways—one for each application. The two response patterns, or modes, have many similarities, but each has its own unique features.

The Character Printing Mode is used for printing characters. A Line Feed command in this mode causes printing followed by immediate advancement of the paper. If the printing buffer contains no print data, the paper is advanced without printing.

The Print Pitch (character spacing) is determined by the space between each printed character and by the Font Style.

Consequently, you must think of Pitch in terms of characters printed per inch—Standard 10 CPI and Condensed 16.7 CPI for normal printing, and 5 CPI and 8.33 CPI for Elongated Printing.

In Graphics Mode, you have complete control of the Print Head. This mode can be used to create a custom letterhead, designs, special type fonts, etc.

However, with Graphic operation, many control codes (which can be used in the Character Printing Mode) cannot be used. The DMP-120 doesn't return an error when you send such a code—it simply ignores the code. This includes codes that change line feed pitch. Graphics Mode uses only one line feed (7/72") to insure full coverage of the paper.

Control Codes

Before investigating the print modes, consider how the TRS-80 communicates with the Printer.

All information is sent to the Printer as numbers between 0 and 255 decimal (00—FF for you Hexadecimal fans). The Printer interprets these numbers according to the American Standard Code for Information Interchange, commonly referred to as the ASCII code. (See **Appendix A** for a list of ASCII codes.) Most numbers (or codes) are printed as letters, numbers, or symbols. However, the numbers 0—31, as well as some special sequences of code numbers, are used to "control" various functions of the Printer. These "Control Codes" allow you to change character sets and select print modes, etc.

The Control Codes have different meanings depending on the current print mode. If a Code is not recognized by the Printer, it is printed as X. The next few sections demonstrate how some of the Control Codes activate various Printer functions. Read these sections carefully.

Sending Control Codes from BASIC

Some Printer features are activated by a single code, but many functions require a sequence of two or more codes. Most multiple code sequences begin with decimal 27 (referred to as the "ESCAPE" code). The ESC code notifies the Printer that a special sequence is on its way. The next code (s) sent determines which Printer feature is selected. In BASIC, use CHR\$ () to send these codes to the Printer.

Note: This section will use the command LPRINT in examples that send codes to the Printer. If you're using a TRS-80 Color Computer, substitute PRINT #-2, for LPRINT.

For instance, set up the DMP-120 as described earlier and enter BASIC in the normal way. Then type the following program:

```
10 LPRINT " CHARACTER" ;  
20 LPRINT CHR$(27) ; CHR$(28)  
30 LPRINT " MODE"
```

and RUN it.

Roll the paper forward and look at the results. The word MODE printed over part of the word CHARACTER. Why? The codes CHR\$(27) and CHR\$(28) are the guilty parties. Take a quick look at **Appendix A**. This chart shows the various code sequences understood by the DMP-120. The Control Code Sequence CHR\$(27); CHR\$(28) means change the forward line feed to half its normal distance.

Character Printing Mode

How can you tell which mode the DMP-120 uses when it's first turned on? A little reflection on the above program tells you all you need to know.

Line Feed commands are not executed immediately in the Character Printing (CP) Mode. The (27, 28) sequence didn't cause a Half Forward Line Feed until after the first line was printed. Thus, the Printer must be in the CP mode. And, in case you missed it, this new Line Feed stays in effect until going into Graphics mode.

Type: LLIST LLIST **(ENTER)**

Sure enough. You still have that short Line Feed.

Graphics Mode

Graphics Mode is very different from the Character Printing Mode. For one thing, Graphics Mode accepts only one Line Feed code—CHR\$(10). This Line Feed is fixed at 7/72". Furthermore, only a few of the Character Printing Mode features are available in the Graphics Mode. Standard letters and symbols, for example, are ignored by the Printer when it is in Graphics Mode. Instead, numeric data from 128 to 255 is translated into dot patterns for the Print Head. This lets you produce high-resolution graphic print-outs of charts, logos, etc.

For a quick look at this Mode in action, change our test program to:

```
10 LPRINT CHR$(18)
20 FOR I=128 TO 255
30 LPRINT CHR$(I);
40 NEXT I: LPRINT CHR$(30)
```

and RUN the program.

CHR\$(18) puts the DMP-120 into Graphics Mode. The numbers 128 through 255 are interpreted as dot patterns.

Type: LPRINT CHR\$(30) (ENTER) to return the Printer to CP Mode. Try LLISTing the program to be sure you're not stuck in Graphics land.

Selecting a Print Mode

Table 4 summarizes the Control Codes required to move from one mode to another.

If you're in:	and want to change to:	Send a CHR\$()::
CP	Graphics	18
Graphics	CP	30

Table 4

Hints and Tips About Print Modes...

Character Printing Mode

- All commands which decide Line Feed pitch are stored in the Printer's memory. They are not executed until a LF code (10 Dec. or 138 Dec.) is received. Then, the paper advances according to the pitch codes stored in the Printer's memory.
- Line Feed commands stay in effect until replaced by a new command.
- All printable characters (except user-defined Graphics) can be printed in this mode.

Graphics Mode

- Only one Line Feed code (10 Dec.) is acceptable. The LF code causes the paper to move 7/72" forward. No other pitch is allowed.
- Decimal numbers 128—255 sent via CHR\$ in BASIC are interpreted as pin firing patterns for the Print Head.
- Only a few code sequences are recognized in the Graphics Mode.

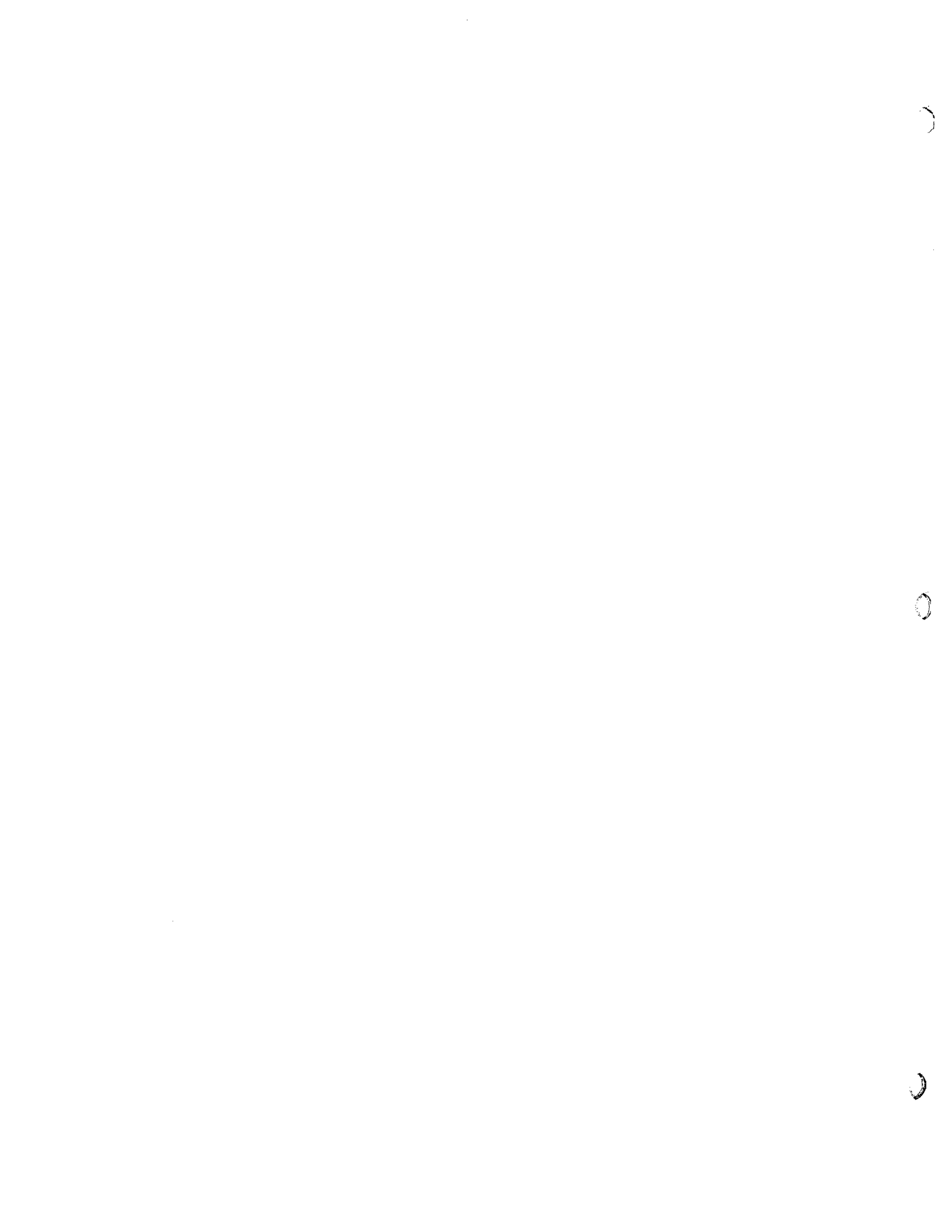

4/ Print Font Styles and Character Widths

The DMP-120 has two distinct print (character) font styles:

- Standard
- Graphic Characters

Each font style is created with a unique dot pattern laid out in a grid or matrix.

The character styles differ in the size of the matrix and the way individual characters are created within the matrix.

The horizontal dot positions overlap; vertical ones don't.

Character Widths and Densities		
Font Style	Matrix Size	Pitch
Standard	9 × 8	Normal 10 CPI/Elongated 5 CPI Condensed 16.7 CPI/Elongated 8.35
Graphics	6 × 6	Normal 10 CPI Condensed 16.7 CPI

Table 5

Table 5 shows that there are two basic pitches.

- Normal
- Condensed

When character pitch is changed (from Normal to Condensed or vice versa), the current line is terminated and printing begins from the beginning of the next line.

Selecting Font Styles

Character styles are selected by Control Codes from the TRS-80 (i.e., via software) during operation.

Character styles stay in effect until another style is selected. Even entering Graphics Mode does not change the font. The DMP-120 returns to the last active font on leaving the Graphics Mode.

Table 6 is a summary of the Character Style change commands.

Send a CHR\$ ():	If you Want:
27 19	Normal
27 20	Condensed
27 14	Start Elongation
27 15	End Elongation

Table 6

Standard Character Font Style

The Standard character set is printed in a 9×8 dot matrix (9 dots wide by 8 dots high).

Each of the Standard characters can be printed in two main character widths:

- Normal 10 Characters Per Inch (CPI)
- Condensed 16.7 CPI

Each of these widths can be elongated (double-width), which gives half as many characters per inch and a total of four different print widths.

You can get a better feel for the different available print widths by printing a few sample lines. Type in this program:

```

NEW ENTER
110 F$="STANDARD"
120 N=19: W$="NORMAL": GOSUB 240
130 N=20: W$="CONDENSED": GOSUB 240
230 LPRINT CHR$(27) CHR$(19) : STOP
240 LPRINT CHR$(27)CHR$(N) F$ "CHARACTER"; W$ "DENSITY"
250 RETURN

```

and RUN it.

The subroutine in line 240 sends the required Control Codes to the DMP-120. Line 230 returns to Normal character width and stops program execution.

Graphic Characters

The third character set is a 6×6 matrix character set used for Block Graphic printing. The characters can be Normal 10 CPI width, or Condensed 16.7 CPI. This set is not fully compatible with the screen graphics of any of the TRS-80 computers; rather it is a unique character set.

A 6×6 dot matrix character set is available in Normal 10 or 5 CPI, and Condensed 16.7 or 8.3 CPI character conditions.

To see how the character widths affect the Graphics characters, add:

```
190 N=19: W$="NORMAL": F$="GRAPHIC": GOSUB 260
200 GOSUB 240: GOSUB 260
220 N=20: W$="CONDENSED": GOSUB 240: GOSUB 260
230 LPRINT CHR$(27);CHR$(19);CHR$(27);CHR$(15): STOP
240 LPRINT CHR$(27)CHR$(N) F$ "CHARACTERS"; W$; "DENSITY"
250 RETURN
260 FOR I=224 TO 254: LPRINT CHR$(I);: NEXT I
270 LPRINT: RETURN
```

and RUN the program.

Since the normal line-to-line spacing is 1/6" or 12 dots high and the Graphic characters are 6 dots high, we can create continuous vertical graphics by using the Half Forward Line Feed (CHR\$(27); CHR\$(28)). Add these lines to the program:

```
10 LPRINT CHR$(27);CHR$(28);
20 FOR R=1 TO 3
30 FOR C=1 TO 7
40 READ N:LPRINT CHR$(N);
50 NEXT C: LPRINT
60 NEXT R: LPRINT CHR$(27);CHR$(54)
70 DATA 241,243,241,224,241,243,241
80 DATA 224,244,241,241,241,249,224
90 DATA 241,248,241,224,241,248,241
```

and RUN.

When you've printed out the results, delete lines 10 through 90.

Wrap-Around

The DMP-120 is a dot-addressable printer. Therefore line length is not determined by the number of characters, but by the number of dots per line. The number of addressable dots-per-line in the Character Printing Mode is:

- Normal = 960
- Condensed = 1600

If the length of text the Printer receives exceeds the limit of dots-per-line, a Line Feed is inserted and the last character is printed from the start of the next line. This is called "wrap-around."

Elongated Characters

Either of the character font styles can be elongated to twice its normal width.

Elongated Printing	
Send CHR\$():	To
27 14	Start Elongation
27 15	End Elongation

Table 7

The start (27 14) and end (27 15) elongated characters may be entered any number of times within a line and can be used in every mode.

You can easily elongate the characters in the current program. Make these changes:

```
100 LPRINT CHR$(27);CHR$(14)
230 LPRINT CHR$(27);CHR$(19);CHR$(27);CHR$(15):STOP
```

and RUN the program.

5/ General Control Codes

Line Feed Codes (LF)

When an LF code (ASCII 10) is received by the DMP-120, all data in the Printer buffer is printed followed by a Line Feed. Unless you tell it otherwise, the DMP-120 uses 1/6" Forward Line Feed when advancing paper.

Pitch settings are sent to the DMP-120 in a two-code sequence. First, a Control Code 27 is sent (CHR\$ (27)). This tells the DMP-120 that a special code sequence will follow. The next number determines the specific pitch. These Control Codes are listed in Table 8.

Line Feed Control Codes	
Send CHR\$ ():	To
27 28	1/2 Forward LF (1/2")
27 54	Full Forward LF (1/6")
27 56	3/4 Forward LF (1/8")

Table 8

Hints and Tips on Line Feed.....

- In the Character Printing Mode, codes are stored in the Printing Buffer. They are not activated until a LF code is sent.
- Line Feed pitch codes have no effect in the Graphics Mode. The Line Feed is set at 7/72" forward.

Special Line Feed Control Codes

A special forward line feed code operates the same regardless of the current print mode. This special code is shown below:

Special Line Feed Control Code	
Send CHR\$ ():	To
27 50	1/12 Forward LF (1/72")

Table 9

This code causes an immediate dump of the Printer buffer, followed by a line feed regardless of the print mode.

This special Line Feed Code is useful for adjusting a print line or printing a dot-matrix picture.

Carriage Return (CR)

A CR Code (13 or 141) tells the Printer to print the current buffer contents, then perform a Carriage Return. If DIP Switch #1 is OFF, one line feed (the current active line feed) will be performed at that time. If Switch #1 is ON, a line feed is not activated and printing continues on the current line.

Ignored or Undefined Codes

Codes that are unusable or undefined in a given mode are either ignored or printed with the symbol **X** which represents an invalid code.

There are several reasons why a code may be unusable in a certain mode. Redundant codes that don't change the current Printer status are usually ignored. For example, if the Printer is in Graphics Mode, sending a CHRS (18) (used to enter Graphics Mode) is useless. And there are many ASCII control codes in the range 0 to 31 that the DMP-120 simply doesn't recognize. ASCII 0, for example, is not used in either print mode.

DMP-120 Ignored Control Codes

All Modes:

- Redundant codes that don't change the current Printer status. For example, if you send a 27 + 14 sequence when Elongation has already been set.

CP: 0, 1, 127, 255, 30

Graphic: All codes in the range 0-127 except LF, CR, 27 + 14, 27 + 15, 27 + 50, and 30.

Codes printed as **X**

CP:

- All codes from 0-31 and 128-159, except the active function codes or the above ignored codes.
-

Table 10

DMP-120 Buffer Operation

The DMP-120's ability to temporarily store data is one of its main advantages over a typewriter. Codes sent to a typewriter (i.e., keys pressed) are transferred immediately to the paper. Codes sent to a Printer are not printed immediately but are stored in a separate section of memory in the Printer called the buffer. When the buffer fills, or certain codes are received (i.e., LF or CR), the buffer is emptied and all data is then printed on the paper. What happens after the buffer data is printed depends on the circumstances. In some cases, printing continues on the same line; in others, the Print Head is moved to a different position relative to the paper.

In the CP Mode, commands for changing print fonts, Line Feed, etc., can be stored in the buffer to take effect when the data is dumped to paper.

Understanding how the buffer works is important for those who wish to gain full control of the DMP-120.

Hints and Tips on the DMP-120 Buffer.....

For CP and Graphics Modes

- The buffer allocates a fixed number of dots, depending on the character width selected. The buffer is emptied when the amount of data stored equals that number.
If different character widths have been used on the same line, the last character added may exceed the dot count. The buffer is printed without this last character.
- The Next Line (NL) feature is selected while switch 1 is OFF (down). When the buffer is emptied, printing will resume at the start of the next print line.
- The Carriage Return code (CR = 13 decimal) automatically activates printing (assuming at least one character code is already in the buffer).
If switch 1 is ON (up), Carriage Return (CR) will occur and the next full buffer will over-print on the current line.
- The Line Feed code (LF = 10) automatically activates printing, and the Print Head is positioned at the start of the next print line.
- If the computer delays more than a second before sending the next print code, the buffer is printed. Printing continues from the current position.

CP Mode only:

- If a character set of a different dot density is selected, the data in the buffer is printed immediately.
Codes for changing character sets are: (27 19), (27 20).
Printing continues in the next line with the new character style.
- Dot graphics printing continues from the current character position.

Graphics Mode only:

- When the "End Graphics Mode" command is received, the buffer is printed.
The Printer returns to the CP Mode and printing continues in the same line from the current print position.

Note: In the description, "next line" means the new line performed by Line Feed operation.

5

0

0

6/ Graphics Mode

In the Graphics Mode, you no longer have pre-defined characters at your disposal. You are responsible for the positioning and the action of the Print Head.

Printing Graphic Patterns

Remember that we said there were 7 vertical dots in a dot-column. You can print any or all of these dots in any combination you want.

Try printing just the top dot.

```
10 LPRINT CHR$(27);CHR$(20);CHR$(18);CHR$(27);CHR$(16);  
CHR$(3);CHR$(31);CHR$(129);
```

How does the CHR\$(129) print just the top dot?

Even though the 7 dots in a dot-column are in a vertical row, they are not numbered sequentially down from 1 to 7.

For instance, you've already seen how to print the top dot in the column, but to print the bottom dot, change the program line to:

```
10 LPRINT CHR$(27);CHR$(20);CHR$(18);CHR$(27);CHR$(16);  
CHR$(3);CHR$(31);CHR$(192);
```

This is fine if you want to print an individual dot, but how do you print a combination of dots?

It's actually quite simple.

1. Specify the Dot #'s (1-64) that represent the individual dots you want to print.
2. Add those individual Dot #'s together.
3. Add the sum of the combined Dot #'s to 128.

For example, if you want to print the first dot (Dot #1), the fourth dot (Dot #8), and the last dot (Dot #64), add them together: $1 + 8 + 64 = 73$. Then add the sum (73) to 128: $73 + 128 = 201$. Use 201 as the addressable dot pattern in the form CHR\$(201):

```
10 LPRINT CHR$(27);CHR$(20);CHR$(18);CHR$(27);CHR$(16);  
CHR$(3);CHR$(31);CHR$(201);
```

Now to flex our muscles.

Type in this NEW program:

```
10 LPRINT CHR$(18)  
30 FOR I=1 TO 20: S=-S  
40 FOR J=0 TO 6  
80 IF S<0 THEN N=N+2*(6-J) ELSE N=N-2*J  
90 LPRINT CHR$(N);  
100 NEXT J: NEXT I  
120 LPRINT CHR$(30)
```

and RUN it. Be prepared for a pause; it takes time to fill the print buffer.

This program alternately adds and subtracts powers of two to the current code pattern stored in the variable N. The net effect is to add or remove a single dot from the preceding dot pattern.

Line Feed

In Graphics Mode, it is assumed that you want to print rows of graphics one right after another, each 7 dots high. Therefore, the Graphics Mode provides only one size line feed. A single line feed advances the paper 7 dots or approximately 0.1 inch. This small paper advance allows for continuous printing without unwanted space between lines.

Modify the current program to demonstrate this fixed line feed. Add or change:

```
20 FOR K=1 TO 2: S=1: N=128
50 IF K=1 THEN 80
60 IF S=0 THEN N=N+20:J ELSE N=N-20(6-J)
70 GOTO 90
110 LPRINT: NEXT K
```

and RUN.

These lines infiltrate the current loop and produce a mirror image of the first pass of the Print Head. The LPRINT in line 110 causes the Line Feed between passes.

Print Density

Horizontal dot density in Graphics Mode is the same as that of the character width prior to entering Graphics Mode. Add to the current sample program:

```
5 LPRINT CHR$(27);CHR$(20);"CONDENSED CHARACTER WIDTH";
```

and RUN

Line 5 activates the Condensed character set. Graphics are then printed in condensed Character density.

Leaving Graphics Mode

CHRS (30) is used to exit Graphics Mode. It returns the DMP-120 to the CP Mode. In addition, all the previous conditions, such as character style, are restored. Change the sample program to:

```
90 LPRINT CHR$(N);
130 LPRINT "STILL IN CONDENSED MODE"
140 LPRINT CHR$(27);CHR$(19)
```

and RUN it.

Sure enough, the condensed mode is still alive and well.

Mixing Modes on the Same Line

The fact that character density is unaffected as the DMP-120 moves in and out of Graphics Mode is a blessing when mixing Text and Graphics on the same line. It simplifies the calculation of the number of dots per line.

Freehand Drawings

Having high-resolution graphics at your disposal is great, but you must realize that it requires plenty of data. The Computer can do most of the work in drawing figures that can be described by a mathematical function. Freehand drawings, on the other hand, require translating the figure into a matrix of dots, then calculating the dot printing combinations for each Print Head position. Since there are 7 dots available for graphics, separate the matrix into rows 7 dots high.

The numbers can be stored in DATA statements. To conserve memory and typing time, store the data as numbers from 0 to 127, then add 128 as you send them to the Printer. Enter these sample DATA lines:

NEW **ENTER**

```
120 DATA 17,33,33,34,-4,66,-4,4,-5,8,-5,16,-5,32,-5,64,999
160 DATA 19,12,112,999
190 DATA 40,39,16,16,8,15,999
210 DATA 16,16,8,8,4,4,2,2,1,1,999
```

The 999's will be used to signify the end of a line. The other numbers are between 0 and 127. Now for the program to read the numbers, add 128, then send them to the Printer:

```
10 LPRINT CHR$(18)
20 FOR R=1 TO 4
30 READ N: IF N=999 THEN 80
40 IF N>=0 THEN LPRINT CHR$(128+N);: GOTO 30
80 LPRINT:NEXT R
90 LPRINT CHR$(30)
100 LPRINT "DMP120"
```

and RUN the program.

Not much to brag about yet. Maybe what it needs is to be jazzed up to repeat a number several times. A good approach is to use negative numbers to indicate the number of repetitions followed by the number to be repeated. Add:

```
120 DATA 17,33,33,34,-4,66,-4,4,-5,8,-5,16,-5,32,-5,64,999
130 DATA 64,96,80,72,68,66,97,112,120,124,-5,126
180 DATA 95,79,71,67,65,32,16,8,4,2,1,0,1,2,4,11,87,75
```

Don't RUN it yet!

In line 120, the sequence -4, 66 is used to mean four 66's: 66,66,66,66. You must modify the program to recognize the negative numbers. Change:

```
40 IF N>=0 THEN LPRINT CHR$(128+N);: GOTO 30
50 READ M
60 FOR L=1 TO -N: LPRINT CHR$(128+M);: NEXT L
70 GOTO 30
```

and RUN it.

The figure still doesn't look like much. Add the remaining DATA lines and see what you've been working on:

```
140 DATA -5,124,-2,120,-3,121,-2,113,-3,114,98,98,-2,100
150 DATA -2,116,92,88,72,64,32,32,16,80,104,72,5,101,51
170 DATA 127,-4,114,-5,59,-5,7,-5,15,-5,31,-5,63,-6,127
200 DATA -5,0,-5,1,-5,2,-5,4,-5,8,-5,32,-4,64,127,32,32
```

Now RUN the program.

Now that's worth the effort!

5

6

7

Appendix A/ Control Code Summary

Code		Character Printing Mode	Graphics Mode	Remarks
Dec.	Hex.			
00 01	00 01	Ignored	Ignored	
10 or 138	0A 8A	Full Line Feed (Executive)	7/72" Line Feed (Executive)... 8A hex, 138 dec.	
13 or 141	0D 8D	Carriage Return (When LF pitch is 1/6" per line)	Carriage Return only 0D hex. (When NL, LF pitch is 7/72")	NL/CR Selectable
014	0E	End Underline	Ignored	
015	0F	Start Underline	Ignored	
18	12	Selects Graphics Mode	Ignored	
27 14	1B 0E	Start Elongation	Start Elongation	
27 15	1B 0F	End Elongation	End Elongation	
27 19	1B 13	Select Standard Characters	Ignored	
27 20	1B 14	Select Condensed Characters	Ignored	
27 28	1B 1C	Half Forward Line Feed (Latched only)	Ignored	
27 50	1B 32	1/12 Forward Line Feed	1/12 Forward Line Feed	
27 54	1B 36	Full Forward Line Feed (Latched only)	Ignored	
27 56	1B 38	3/4 Forward Line Feed (Latched only)	Ignored	
30	1E	Ignored	End Graphics Mode	

Code		Character Printing Mode	Graphics Mode	Remarks
Dec.	Hex.			
127	7F	Ignored	Ignored	
255	FF	Ignored	(Printing Data)	
Other Codes in Function Area (02 to 31 decimal) (02 to 1F Hex.)		Prints "X" marks	Ignored	
Other Codes in Function Area (128 to 159 decimal) (80 to 9F Hex.)		Prints "X" marks	(Printing Data)	

Appendix B/ Interfacing

The DMP-120 has two kinds of interface. The primary is 8-bit parallel interface with strobe signal. The secondary is 8-bit or 7-bit 3-wire serial interface. Each interface will be selected by setting of Function Selection switch 4.

Parallel Interface

A 36-pin plastic female connector located at the right rear of the printer provides the means for connecting the printer to a computer.

The pin arrangement of the connector, signal summary, and the interface timing are shown below.

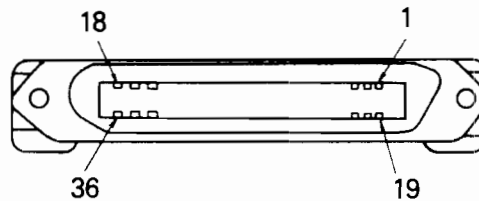

Parallel Interface Connector Pin Arrangement

SIGNAL PIN	RETURN PIN	NAME OF SIGNALS
1	19	STROBE
2	20	DATA 1
3	21	DATA 2
4	22	DATA 3
5	23	DATA 4
6	24	DATA 5
7	25	DATA 6
8	26	DATA 7
9	27	DATA 8
10	28	ACK
11	29	BUSY
12	—	PE (Paper out)
13	—	BUSY
14	—	OV
15	—	NC
16	—	OV
17	—	CHASSIS GROUND
18	—	5V (80mA Maximum)
30	—	OV
31	—	NC
32	—	FAULT (Printer Error Condition)
33	—	NC
34	—	NC
35	—	NC
36	—	NC

- Signal level

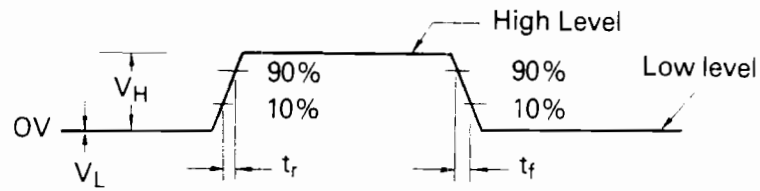

Figure 3. Parallel Interface Signal Waveform

$t_r \leq 30 \text{ n s.}$
 $t_f \leq 30 \text{ n s.}$

$2.4\text{V} \leq V_H \leq 5.0\text{V}$
 $0\text{V} \leq V_L \leq 0.4\text{V}$

Parallel Interface Signal Waveform

- Allowable Cable Length

Twisted pair cable Up to 5m
 Flat cable Up to 2m

- Parallel Interface Timing

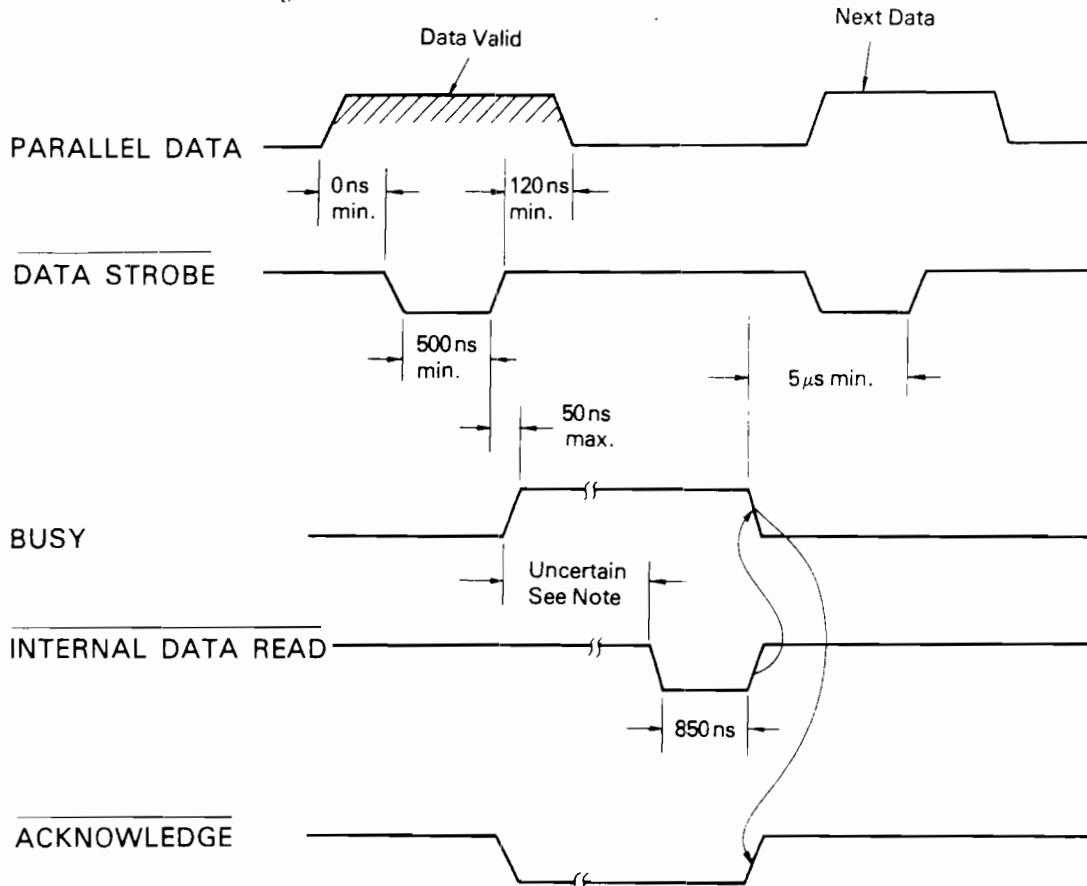

Parallel Interface Data Transmission Timing

Note: 250 μs minimum

In case of discontinuous transmission, the BUSY condition occupies much time.

Serial Interface

A four-pin plastic female connector located at center rear of the printer provides the means for connecting the printer to a computer. The serial interface will be selected by setting of Function Selection switch 4 (to the CLOSE side) from two rates (600 BPS and 1200 BPS) by Function Selection switch 3 which OPEN side designates 1200 BPS and CLOSE side designates 600 BPS.

- Pin-Configuration of serial RS-232C DIN Jack

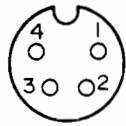

DIN Jack

Pin No.	Signal
1	NOT USED
2	$\overline{\text{BUSY}}$
3	GND
4	$\overline{\text{DATA}}$

• Timing Chart of Serial Interface

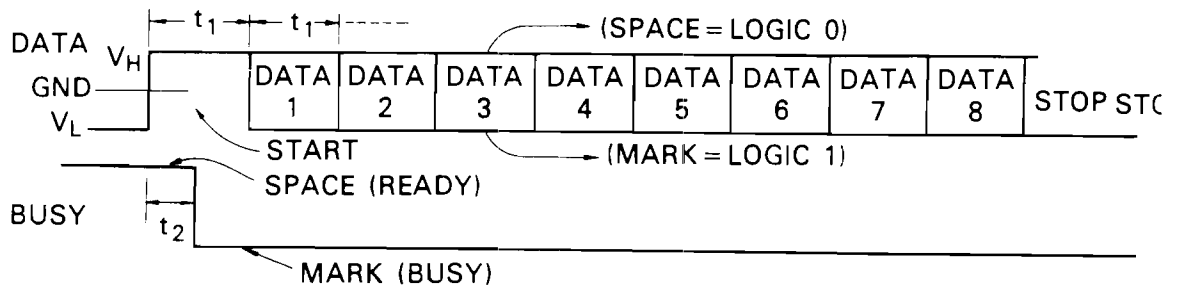

	Baud Rate	t_1	t_2
$+3V \leq V_H \leq +25V$	600 BPS	1.57m Sec.	0.83m Sec.
$-3V \leq V_L \leq -25V$	1200 BPS	0.83m Sec.	0.42m Sec.

Note: DATA 1 is LSB and DATA 8 is MSB.

Serial Interface Timing Chart

Remarks in Serial Interfacing Condition

When a stop bit ERROR is detected, the Printer changes received code to a special code. In Bit Image mode this special code is unprintable code and is ignored. In Character-Printing mode this indicates an "X" mark code.

The Printer checks only the stop bit and gives no heed to the 2nd stop bit when a two stop bit condition exists.

When Serial Interface is selected and the Printer connected to host device with a cable if the host is powered OFF or if the Printer is not connected to the host, it may receive uncertain character code and printing may be performed without any control. In these case the ON-LINE/OFF-LINE Switch of the Printer should be turned to OFF-LINE side.

Appendix C/ Character Sets

The DMP-120 has 154 dot matrix patterns in the ROM (Read Only Memory). The following is a table of the character codes.

								00	01	02	03	04	05	06	07	08	09	10	11	12	13	14	15					
0	0	0	0	0	0	0	0	0	0	0	0	0	0	0	0	0	0	0	1	1	1	1	1	1	1	1	1	
0	0	0	0	0	1	1	1	0	1	1	1	1	1	1	1	1	1	1	0	0	0	0	0	1	1	1	1	
0	0	1	1	0	0	0	1	0	1	0	0	1	1	0	0	1	1	0	0	1	1	0	0	1	1	1	1	
0	1	0	1	0	1	0	1	0	1	0	1	0	1	0	1	0	1	0	1	0	1	0	1	0	1	0	1	
0	0	0	0	0	0	0	0	NUL	POS	(Space)	0	@	p	▼	p					Y							(Blank)	r
0	0	0	1	1				SOH	DC1	1	1	A	Q	a	q					á	A							—
0	0	1	0	2				STX	DC2	2	2	B	R	b	r					c	Ö							7
0	0	1	1	3				ETX	DC3	3	3	C	S	c	s					E	U							T
0	1	0	0	4				EDY	DC4	4	4	D	T	d	t					É								†
0	1	0	1	5				ENC	NAK	%	5	E	U	e	u					µ								‡
0	1	1	0	6				ACK	SYN	&	6	F	V	f	v					°	a							L
0	1	1	1	7				BEL	ETA	7	7	G	W	g	w					▼	o							J
1	0	0	0	8				BB	CAN	l	8	H	X	h	x					†	ü							†
1	0	0	1	9				HT	EM)	9	I	Y	i	y					§	J							†
1	0	1	0	10				LF	SUB	*		J	Z	j	z	LF												—
1	0	1	1	11				VT	ESC	+		K	l	k	l					:	é							†
1	1	0	0	12				FF	FS	.	<	L	\	l	l					1/4	ü							†
1	1	0	1	13				CR	GS	-	=	M	l	m	l	CR					e							†
1	1	1	0	14				EO	RS	.	>	N	^	n	-					1/2								†
1	1	1	1	15				ST	US	.	>	O	_	o	(DEL)					€	f							(DEL)

The printable characters may be classified as follows:

- Condensed or Condensed Elongated
 - Standard or Standard Elongated
- | | | |
|---|-----------------------|----|
| } | ASCII..... | 94 |
| } | European Symbols..... | 25 |
| } | Block Graphics..... | 30 |

94 ASCII Code

Standard or Condensed

Code			Char.	Code			Char.	Code			Char.
Dec.	Hex.	Oct.		Dec.	Hex.	Oct.		Dec.	Hex.	Oct.	
32	20	40	(Space)	64	40	100	@	96	60	140	↘
33	21	41	!	65	41	101	A	97	61	141	a
34	22	42	"	66	42	102	B	98	62	142	b
35	23	43	#	67	43	103	C	99	63	143	c
36	24	44	\$	68	44	104	D	100	64	144	d
37	25	45	%	69	45	105	E	101	65	145	e
38	26	46	&	70	46	106	F	102	66	146	f
39	27	47	'	71	47	107	G	103	67	147	g
40	28	50	(72	48	110	H	104	68	150	h
41	29	51)	73	49	111	I	105	69	151	i
42	2A	52	*	74	4A	112	J	106	6A	152	j
43	2B	53	+	75	4B	113	K	107	6B	153	k
44	2C	54	,	76	4C	114	L	108	6C	154	l
45	2D	55	-	77	4D	115	M	109	6D	155	m
46	2E	56	.	78	4E	116	N	110	6E	156	n
47	2F	57	/	79	4F	117	O	111	6F	157	o
48	30	60	0	80	50	120	P	112	70	160	p
49	31	61	1	81	51	121	Q	113	71	161	q
50	32	62	2	82	52	122	R	114	72	162	r
51	33	63	3	83	53	123	S	115	73	163	s
52	34	64	4	84	54	124	T	116	74	164	t
53	35	65	5	85	55	125	U	117	75	165	u
54	36	66	6	86	56	126	V	118	76	166	v
55	37	67	7	87	57	127	W	119	77	167	w
56	38	70	8	88	58	130	X	120	78	170	x
57	39	71	9	89	59	131	Y	121	79	171	y
58	3A	72	:	90	5A	132	Z	122	7A	172	z
59	3B	73	;	91	5B	133	!	123	7B	173	!
60	3C	74	<	92	5C	134	\	124	7C	174	\
61	3D	75	=	93	5D	135		125	7D	175	
62	3E	76	>	94	5E	136	^	126	7E	176	^
63	3F	77	?	95	5F	137	-				-

Note: The following characters are descended by one dot: small letters; g, p, q, y, j.

25 European Symbol Code

Standard or Condensed Character Set

Dec.	Code		Char.
	Hex.	Oct.	
160	A0	240	(Blank)
161	A1	241	á
162	A2	242	ç
163	A3	243	£
164	A4	244	(Blank)
165	A5	245	μ
166	A6	246	°
167	A7	247	▼
168	A8	250	+
169	A9	251	§
170	AA	252	(Blank)
171	AB	253	€
172	AC	254	¼
173	AD	255	(Blank)
174	AE	256	½
175	AF	257	¶
176	B0	260	¥
177	B1	261	Ä
178	B2	262	Ö
179	B3	263	Ü
180	B4	264	©
181	B5	265	(Blank)
182	B6	266	ä
183	B7	267	ö
184	B8	270	ü
185	B9	271	ß
186	BA	272	(Blank)
187	BB	273	é
188	BC	274	ù
189	BD	275	è
190	BE	276	(Blank)
191	BF	277	f

Note: 1. The "optimizer function" allows the following: If a spacing code is received, the carriage moves only the shortest distance, and the action will take place without unnecessary movement. This saves printing time. When the character data are sent to the Printer within a 1-sec. interval, the Printer automatically stores them until: (1) Function codes are sent, or (2) when the interval is greater than 1-sec. The printing is then executed. (See page 26.) If a blank code is received in the Standard or Condensed character set condition, the carriage will move in the same manner as when receiving a printable character. When printing, the use of blank code can be very convenient, and produce attractive/useful printouts.

Note: 2. The following characters are descended by one dot: ç, μ, §, ß.

30 Block Graphic Character Set

Standard or Condensed Character Set

Code			Char.	Code			Char.
Dec.	Hex	Oct.		Dec.	Hex	Oct.	
224	E0	340	(Blank)	240	F0	360	┐
225	E1	341	▪	241	F1	361	—
226	E2	342	▪	242	F2	362	┌
227	E3	343	▪	243	F3	363	┘
228	E4	344	▪	244	F4	364	└
229	E5	345	┌	245	F5	365	┌
230	E6	346	┐	246	F6	366	└
231	E7	347	—	247	F7	367	┘
232	E8	250	—	248	F8	370	┐
233	E9	351	┌	249	F9	371	┘
234	EA	352	┐	250	FA	372	+
235	EB	353	┐	251	FB	373	┐
236	EC	354	┐	252	FC	374	┐
237	ED	355	┐	253	FD	375	┐
238	EE	356	┐	254	FE	376	┐
239	EF	357	■				

- Note: 1.** These characters are composed of six vertical dots. When using these codes to prepare diagrams, etc., Half Forward Line Feed should be used instead of LF code. If another pitch is used, accurate diagrams are not composed.
- Note: 2.** When continuous graphics or specific dots printing must be performed, be sure to pause for at least one minute after every 10 minutes of graphics printing.

Appendix D/ Programming Information

The following items should be considered when you program the Computer.

1. Printer Power on:
 - Selects optional function set by Function Selection Switch.
Full Forward Line Feed is set if CP mode is selected.
 - Sets normal character. (not Elongated or Bold)
 - Completely clears buffer memory.
2. Each character font can be intermixed with the other style of characters in the same line. However, the Printer will insert dot spaces to insure that the new dot position is valid for the current character size. This may cause unexpected auto-wraparound. To prevent this, intermix characters only on short lines, or don't mix character sizes on the same line.
3. Elongated (Double-width) characters are not terminated at the end of the line and printing continues until a terminating command is received.
4. You should avoid wrap-around. Wrap-around will disturb the dot count of the text in a line.
5. Under block graphic printing, Half Line Feed Forward should be used for printing of diagrams.
6. Line Feed in Graphics Mode is different from Line Feed pitches in the CP Mode. It will generate an odd vertical spacing in Graphics Mode. Consider the following relationship between Line Feed pitches.
 - 11 times at Full Line Feed = 18 times at Graphic Line Feed
 - 11 times at Half Line Feed = 9 times at Graphic Line Feed
7. Graphic printing can be intermixed with character printing in the same line. Dot density in Graphics Mode is the same as the density of the former character style.

Programming Examples

Note to Model II Programmers:

If the Printer goes off-line during a print operation, and remains off-line for a certain period of time, Model II TRSDOS will present an error message. Application programs should be written to trap such errors, inform the operator of the error condition, and give the operator a chance to correct the condition and continue printing. If it is a BASIC applications program, an I/O error will occur, and the operator may type `CONT (ENTER)`.

The BASIC statements `LPRINT` and `LLIST` output to the line Printer. See your Computer's Reference Manual for syntax details. If you have a Color Computer, read all `LPRINT` as `PRINT # -2`.

Example:

LLIST

Lists the resident program to the Printer.

LPRINT "THIS IS A TEST"

Prints the message in quotes and tells the Printer that the next printable character brings a new line.

LPRINT "THIS IS PART OF A LINE"; LPRINT "THIS IS THE REST"

Prints both messages on the same line (because of the semicolon).

The next printable character received starts a new line.

LPRINT "SMALL"; CHR\$ (27); CHR\$ (14); "LARGE"; CHR\$ (27); CHR\$ (15); "SMALL AGAIN"

Prints both normal and elongated characters on the same line.

LPRINT CHR\$ (27); CHR\$ (20); "CONDENSED"; CHR\$ (27); CHR\$ (19) "STANDARD"

Prints condensed and standard characters on different lines.

LPRINT CHR\$ (19); "START"; CHR\$ (27); CHR\$ (56); CHR\$ (138); "ONE LINE"; CHR\$ (138); "TWO LINE"

Prints these letters at 3/4 line pitch.

LPRINT CHR\$ (18); CHR\$ (255); CHR\$ (247); CHR\$ (227); CHR\$ (193); CHR\$ (227); CHR\$ (247); CHR\$ (255); CHR\$ (30)

Prints a special symbol in Graphics Mode.

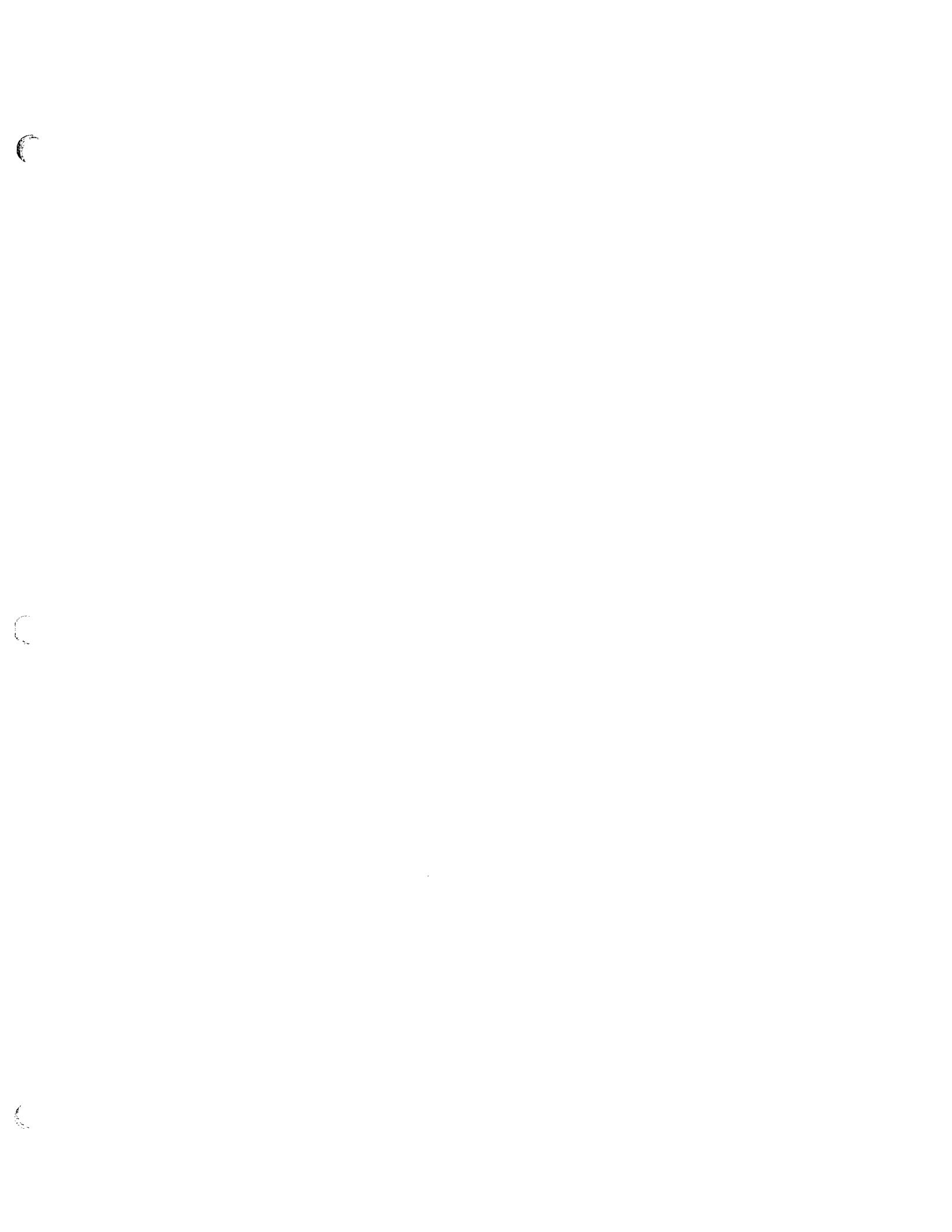

Appendix F/ Schematic Diagram

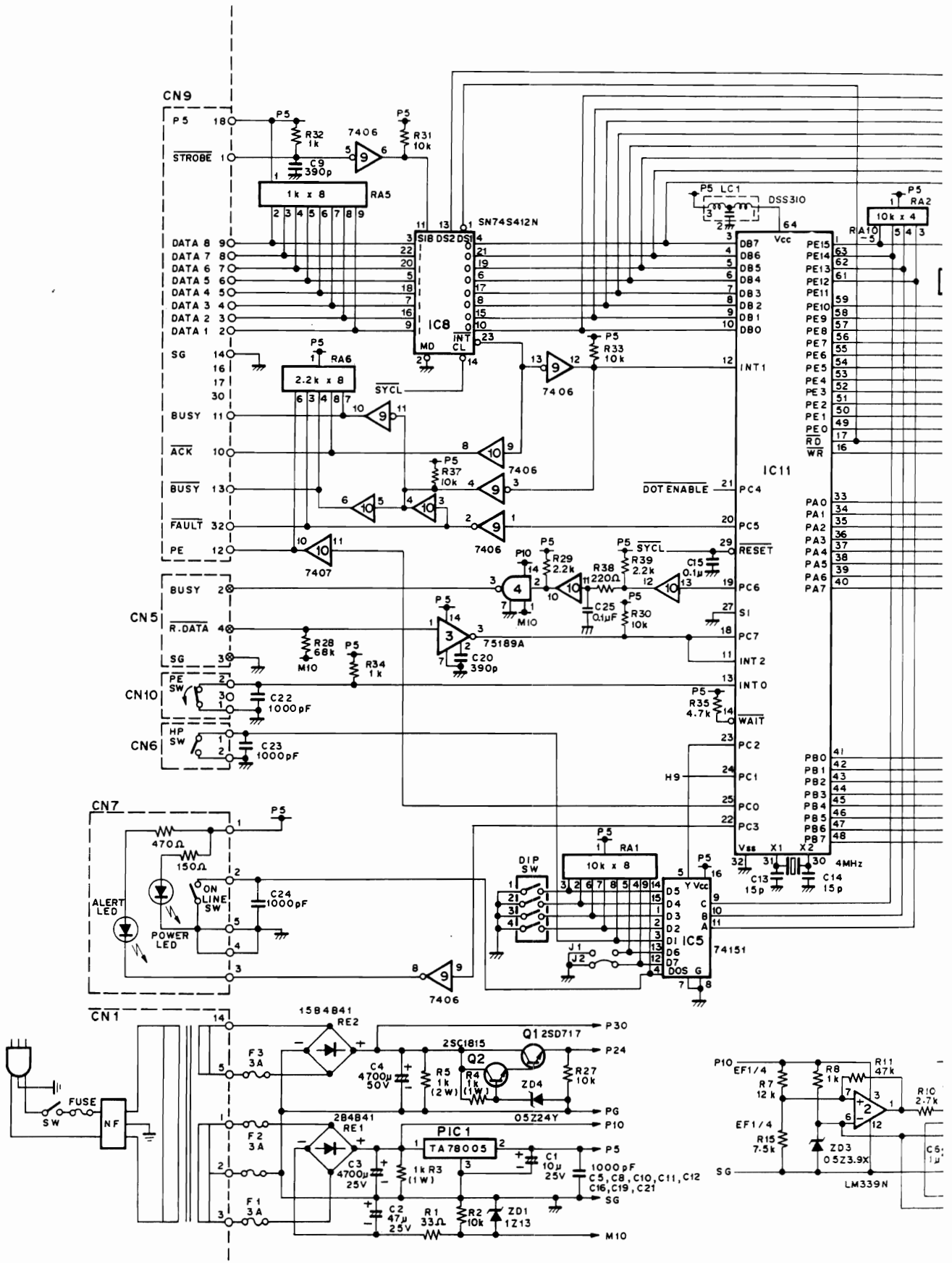

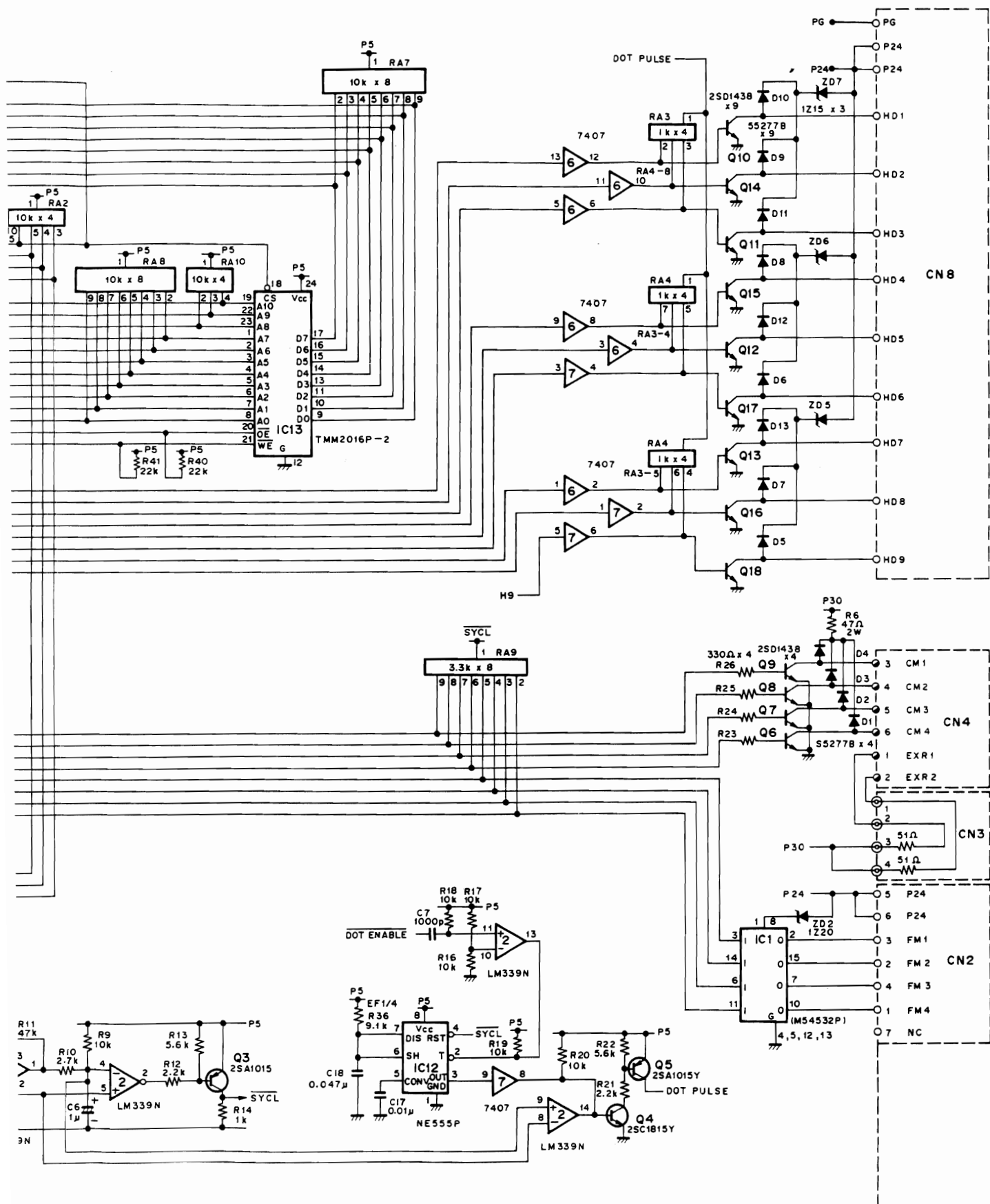

Appendix G/ Specifications

Printing speed	
Standard 10 CPI	120 characters per second
Elongated Standard 5 CPI	60 characters per second
Condensed 16.7 CPI	125 characters per second
Elongated Condensed 8.3 CPI	62.5 characters per second
Characters Per Line	
Standard 10 CPI	80 characters per line
Elongated Standard 5 CPI	40 characters per line
Condensed 16.7 CPI	133 characters per line
Elongated Condensed 8.3 CPI	66 characters per line
Dots Per Character	
Standard 10 CPI	12 dots per character
Elongated Standard 5 CPI	24 dots per character
Condensed 16.7 CPI	12 dots per character
Elongated Condensed 8.3 CPI	24 dots per character
Vertical Spacing	12, 6, 8 lines per inch (Computer selectable), 7/72" and 1/72" (1/12 line feed) available. (Bidirectional when 12 or 6 lines per inch are selected.)
Dots Per Line	
Standard 10 CPI	960 dots
Elongated Standard 5 CPI	960 dots
Condensed 16.7 CPI	1600 dots
Elongated Condensed 8.3 CPI	1600 dots
Character set	
Condensed, Standard	ASCII.94, European Symbols 25, Block Graphics 30
Interface	
Parallel	8-bit with strobe signal
Serial	8-bit, Baud rate selectable (600 BPS or 1200 BPS).
Print Head Life	2000 Hours typical
Preventive Maintenance	Normally every 6 months
Temperature and Humidity Range	
Operating	41°F—104°F (5°C—40°C) 40—80% RH
Storage	-40°F—160°F (-40°C—71°C) 20%—90% RH
Paper	
Fanfold Paper	4"-10" wide with guide holes
Single Sheets	4"-11" wide, good quality, 40-60 kg (14-22 lb)
Roll Paper	8.5" wide, 1" core, 5" dia. Max.
Copy Paper	1 original, 2 copies 34 kg (11 lb) non-carbon paper

Ribbon Cassette	Radio Shack Catalog Number 26-1483 26-1489 (Refill pack)
Power Requirements	120 VAC, 60 Hz, (for USA/Canada), or 220 V/240 VAC, 50 Hz (for European and Australian models). 32 W maximum.

IMPORTANT INFORMATION

This equipment generates and uses radio frequency energy. If it is not installed and used properly, that is, in strict accordance with the manufacturer's instructions, it may cause interference to radio and television reception. It has been type tested and found to comply with the limits for a Class B computing device in accordance with the specifications in Subpart J of Part 15 of FCC Rules, which are designed to provide reasonable protection against such interference in a residential installation. However, there is no guarantee that interference will not occur in a particular installation. If this equipment does cause interference to radio or television reception, which can be determined by turning the equipment off and on, the user is encouraged to try to correct the interference by one or more of the following measures:

- reorient the receiving antenna
- relocate the computer with respect to the receiver
- move the computer away from the receiver
- plug the computer into a different outlet so that computer and receiver are on different branch circuits.

If necessary, the user should consult the dealer or an experienced radio/television technical for additional suggestions. The user may find the following booklet prepared by the Federal Communications Commission helpful: **How to Identify and Resolve Radio-TV Interference Problems**. This booklet is available from the United States Government Printing Office, Washington, DC 20402, Stock No. 004-000-00345-4.

Warning: This equipment has been certified to comply with the limits for a Class B computing device, pursuant to Subpart J of Part 15 of FCC Rules. Only peripherals (computer input/output devices, terminals, printers, etc.) that are certified to comply with the Class B limits may be attached to this computer. Operation with non-certified peripherals is likely to result in interference to radio and TV reception.

RADIO SHACK, A DIVISION OF TANDY CORPORATION

**U.S.A.: FORT WORTH, TEXAS 76102
CANADA: BARRIE, ONTARIO L4M 4W5**

TANDY CORPORATION

AUSTRALIA	BELGIUM	U. K.
91 KURRAJONG ROAD MOUNT DRUITT, N.S.W. 2770	PARC INDUSTRIEL DE NANINNE 5140 NANINNE	BILSTON ROAD WEDNESBURY WEST MIDLANDS WS10 7JN