

HARDWARE-SOFTWARE TAPE CONDITIONER FOR TRS-80 COMPUTERS

BY CASS R. LEWART

WHEN difficulties occur in loading data from a cassette tape into a microcomputer, it is usually because the commercial tapes being used are poorly duplicated. This is further compounded by the quality of the tape itself and even the inadequacies of home tape machines. In the case of the popular TRS-80, a narrow tape level setting range and fussy timing requirements exacerbate the problem. Though the "Peak-Reading Meter" in the February 1980 issue of POPULAR ELECTRONICS enables one to set the proper level quickly, it does not correct for poorly shaped pulses or timing jitter, both of which are major obstacles to successful loads. The Tape Regenerator project described here has been designed for this purpose.

The Regenerator is an advanced breed of tape-conditioning device. It is for use with TRS-80 Level II BASIC and machine language (SYSTEM) pro-

Reshaping and retiming data pulses ends cassette-tape loading problems for BASIC and SYSTEM data

grams. Unlike other commercially available conditioners, it uses both hardware and software. As a result, the computer itself is used for curing timing problems.

This permits properly timed backup copies to be made on a second recorder, which, without internal retiming, would produce backup copies that retain or worsen timing jitter.

How It Works. The ideal signal waveform and typical "good" and "poor" waveforms found on commercial copies of Level II programs are shown in Fig. 1. As shown in Fig. 1C, superimposed noise, power-line hum, amplitude distortion, and ringing and displacement of the data pulse relative to the clock pulse (timing jitter) can make it likely that the computer will lose bits. And a single lost bit, of course, makes the entire program useless.

Once a BASIC program has been properly loaded, a back-up copy of it can be made using the CSAVE command. Similarly, a backup copy of a machine language (SYSTEM) program can be

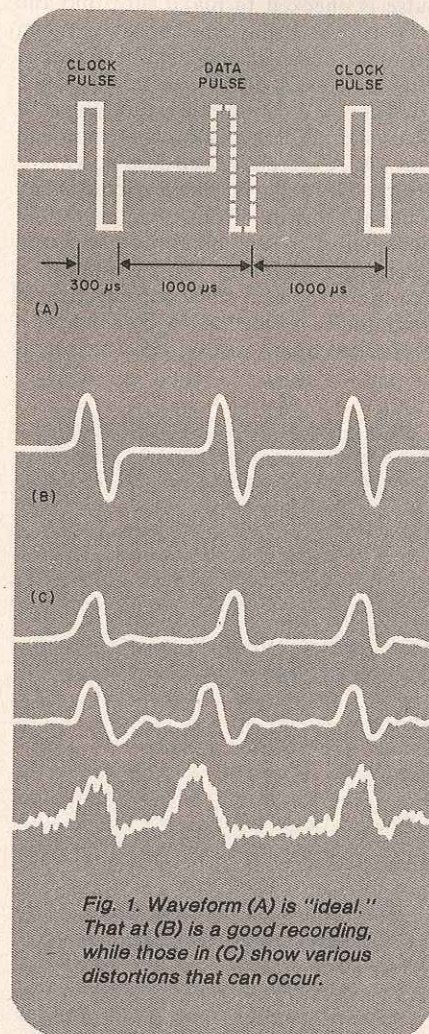

Fig. 1. Waveform (A) is "ideal." That at (B) is a good recording, while those in (C) show various distortions that can occur.

made with a monitor program, e.g. Radio Shack T-BUG. However, the original program must be readable and short enough to fit into memory without overwriting a monitor program.

The Tape Regenerator and the associated program, DUB3 (see Table), overcome these limitations by reshaping and retiming the pulses to produce new tape that the TRS-80 can easily read.

Multiple-segment programs (some programs feature a separate loader) or several programs on a single tape pose no problems for the Regenerator either. Operating on one pair of clock/data pulses at a time without storing the whole program in RAM as monitor programs do, the Regenerator allows even a TRS-80 computer with only 4K of RAM to make back-up copies of arbitrarily large programs and handle tapes containing multiple programs in a single cassette pass.

To test soundness of the Tape Regenerator design, the author created five generations of the same program and found that the fifth-generation tape would load as easily as the original.

Circuit Description. The circuit shown in Fig. 2 reshapes the clock and data pulses received from the tape recorder and feeds them to the computer. Audio transformer T1 provides dc isolation between the tape recorder and the Regenerator circuit. Switch S1 and diodes D1 and D2 allow selection of the "better" half of the pulse (see Control Adjustments later on), while zener diode D3 and transistor Q1 further shape the incoming signal. One OR gate in IC1 decodes the IN command from the computer (via the P1 connector) indicating that the computer is ready to accept data. When the command occurs, IC1 (pin 8) then activates IC2 (via pin 15) to allow the amplified tape recorder signals

to pass via the connector P1 and the expansion port to the computer data bus. Indicator LED2 and optional meter M1 indicate that the tape recorder is sending data at the proper level, and LED3 glows when regenerating program DUB3 is up and running. If no back-up copies are required, J2 provides a "quick and dirty" direct output to the TRS-80 via the tape-recorder plug. The signal at this point is not retimed and is only partially reshaped. This limited processing may make a tape readable.

Power for the circuit (Fig. 3), is provided by transformer T2 in conjunction with voltage regulator IC3, bridge circuit RECT1, and capacitors C1 and C2. Power on is indicated by LED1.

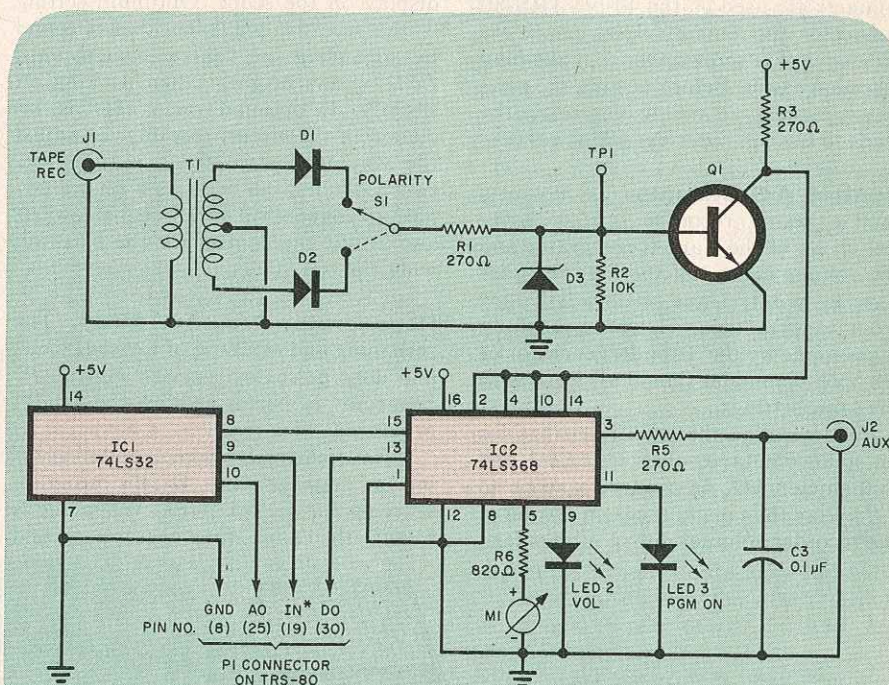

Fig. 2. The Tape Regenerator is controlled by signals from the TRS-80 that are determined by the DUB3 program. A second recorder is connected to the auxiliary output at jack J2.

PARTS LIST

- | | |
|---|---|
| C1—200- μ F, 35-V electrolytic | R2—10-k Ω , 1/2-W resistor |
| C2,C3—0.1- μ F disc capacitor | R4,R6—820- Ω , 1/2-W resistor (optional) |
| D1,D2—1N914 silicon diode | RECT1—50-V, 1-A bridge rectifier |
| D3—3.9-V zener diode | S1,S2—Spdt switch |
| IC1—74LS32 quad OR gate | T1—Audio transformer (Radio Shack 273-1380 or similar) |
| IC2—74LS368 hex tri-state buffer | T2—12-volt transformer (Radio Shack 273-1385 or similar) |
| IC3—7805 +5-volt regulator | Misc.—Suitable enclosure, 2 DIP sockets (14 pin and 16 pin) line cord, solder, etc. |
| J1,J2—Miniature phone jack | Note—The following is available from Southwest Technical Products, 219 W. Rhapsody, San Antonio, TX 78216, Dept. TR-1: complete kit of parts including a pc board and listing of DUB3 program in BASIC to allow POKEing into memory, but excluding M1, at \$29.95 postpaid. Texas residents, add 4% sales tax. |
| LED1,LED2,LED3—Red light-emitting diode | |
| M1—1-mA meter (Radio Shack 270-1752 or similar) | |
| P1—2 \times 20 edge connector on 0.1" centers to fit expansion port on TRS-80 keyboard or expansion interface | |
| Q1—Npn Darlington Transistor (HEPS9100 or similar) | |
| R1,R3,R5—270- Ω , 1/2-W resistor | |

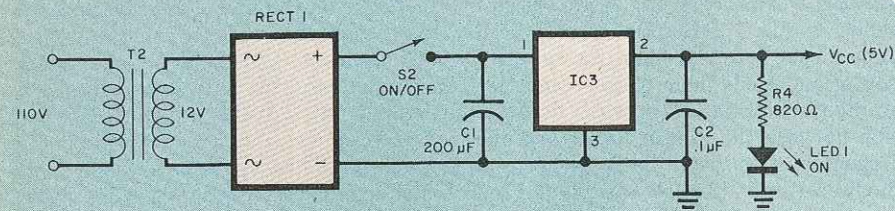

Fig. 3. The power supply is a simple rectifier-regulator circuit as shown here.

Construction. The circuit can be assembled on a small pc board, or Wire-Wrap techniques can be used. Keep all leads as short as possible. As only four contacts are used on the 40-pin TRS-80 connector, the remaining pins can be expanded with a screwdriver to make plug insertion easier. Before turning the power on, recheck all wiring, especially the leads to the computer expansion port.

Control Adjustments. To properly read a poorly recorded tape, polarity switch *S1* of the Tape Regenerator and the volume control of the tape recorder have to be set. These settings will vary from tape to tape. However, back-up tapes made by the Tape Regenerator or CSAVE command should all work with the same settings.

To determine the proper settings for an unknown tape, observe *LED2* and milliammeter *M1*, or connect a scope to *TP1*. Play the tape at medium setting of the recorder volume control. Flip polari-

ty switch *S1* and leave it in the position corresponding to a stronger signal as evidenced by a brighter LED, higher reading on the meter, or a cleaner pulse display on the scope. Optimum setting of the recorder playback level is found by advancing the volume control until *LED2* glows brightly, then backing off slightly. If optional meter *M1* is included in the circuit (see Fig. 2) adjust the volume control for a reading between 0.5 and 0.6 mA. As a final alternative, connect an oscilloscope to *TP1* and adjust the control for the cleanest, widest pulses you can.

Regenerator Program DUB3. The reshaping and retiming of Level-II clock and data pulses as received via the *P1* connector is performed by the DUB3 program.

After clearing the screen and displaying a message, the DUB3 program searches for a clock pulse. When one is found, the time interval to a second

pulse is checked to make sure that the first was not a spurious transient. When the clock pulse is confirmed, it is output after a 200-µs delay using subroutine OUTPUT. This subroutine produces a clean signal lasting 300 µs as shown in Fig. 1A. A search for the data pulse now begins. The delay of 500 µs excludes any residual ringing from the preceding clock pulse. If no data pulse is found during the following 700-µs window, a search for the next clock pulse begins. If a data pulse is detected in the window, it is checked again to exclude a transient

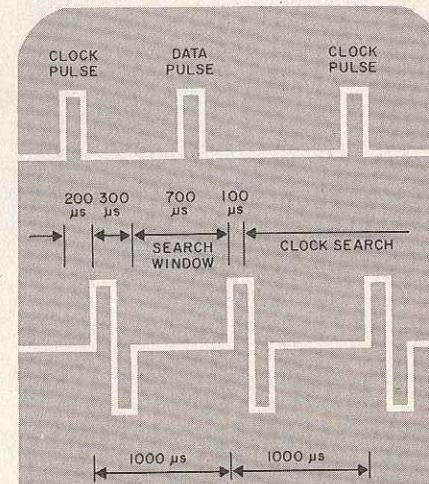

Fig. 4. Timing diagram of DUB3 program. Input at *TP1* is at top. Below is output from computer.

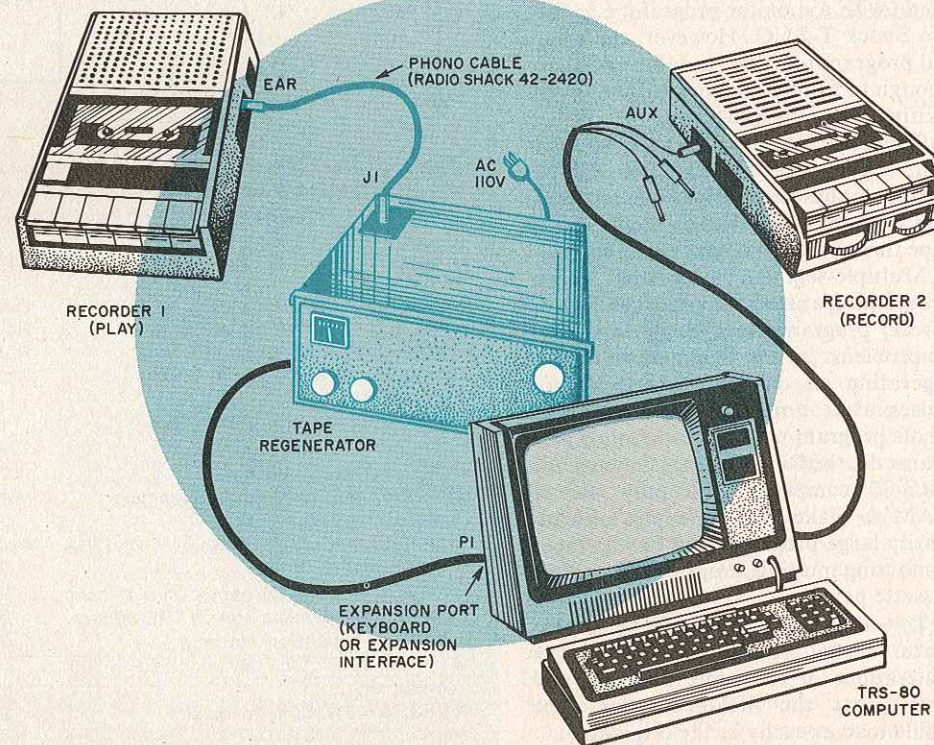

Fig. 5. Electrical interconnection of the Tape Regenerator to the TRS-80 computer and two tape recorders.

TABLE—LISTING OF DUB3 PROGRAM

00100	PORT	EQU	00H	
00110	CENTER	EQU	04H	
00120	HIGH	EQU	05H	
00130	LOW	EQU	06H	
00140	DL100	EQU	0CH	
00150	DL150	EQU	12H	
00160	LEN1	EQU	14H	
00170	DL200	EQU	1AH	
00180	DL700	EQU	22H	
00190	LEN2	EQU	22H	
00200	CASS	EQU	0FFH	
00210	CLS	EQU	01C9H	
00220	LINE1	EQU	3DD6H	
00230	LINE2	EQU	3E0FH	
00240		ORG	4A00H	
00250	DUB3	CALL	CLS	;CLEAR SCREEN
00260		LD	HL,TAB1	;DISPLAY LINE1
00270		LD	DE,LINE1	
00280		LD	BC,LEN1	
00290		LDIR		
00300		LD	HL,TAB2	;DISPLAY LINE2
00310		LD	DE,LINE2	
00320		LD	BC,LEN2	
00330		LDIR		
00340	START	LD	B,DL100	;100 MICS DELAY
00350	DELO	DJNZ	DELO	
00360	SRCHC	IN	A,(PORT)	;START CLOCK PULSE SEARCH
00370		RRA		
00380		JR	NC,SRCHC	;CLOCK PULSE FOUND?
00390		IN	A,(PORT)	;YES, TRANSIENT ONLY?
00400		RRA		
00410		JR	NC,SRCHC	;YES, KEEP SEARCHING
00420		LD	B,DL200	;NO, SET 200 MICS DELAY
00430	DEL1	DJNZ	DEL1	
00440		CALL	OUTPUT	;PUT OUT CLOCK PULSE
00450		LD	B,DL700	;START 700 MICS READ WINDOW
00460	SRCHD	IN	A,(PORT)	;SEARCH FOR DATA PULSE
00470		RRA		
00480		JR	C,FOUND1	;FOUND?
00490		DJNZ	SRCHD	;NO, WINDOW TIMED OUT?
00500		JR	START	;YES, SEARCH FOR CLOCK PULSE
00510	FOUND1	IN	A,(PORT)	;TRANSIENT ONLY?
00520		RRA		
00530		JR	C,FOUND2	;NO
00540		DJNZ	SRCHD	;YES, WINDOW TIMED OUT?
00550		JR	START	;YES SEARCH FOR CLOCK PULSE
00560				;DATA PULSE FOUND,
00570	FOUND2	INC	IX	;WASTE 10 CYCLES
00580		BIT	3,(HL)	;WASTE 12 CYCLES
00590		DJNZ	FOUND2	;WINDOW TIMED OUT?
00600		CALL	OUTPUT	;YES, PUT OUT DATA PULSE
00610		JR	START	;SEARCH FOR CLOCK PULSE
00620	OUTPUT	LD	A,HIGH	;PULSE OUTPUT
00630		OUT	(CASS),A	;PULSE HIGH
00640		LD	B,DL150	;150 MICS DELAY
00650	DEL2	DJNZ	DEL2	
00660		LD	A,LOW	
00670		OUT	(CASS),A	;PULSE LOW
00680		LD	B,DL150	;150 MICS DELAY
00690	DEL3	DJNZ	DEL3	
00700		LD	A,CENTER	
00710		OUT	(CASS),A	;RESTORE TO CENTER
00720		RET		
00730	TAB1	DEFM	'TAPE BACK-UP PROGRAM'	
00740	TAB2	DEFM	'COPYRIGHT (C) 1980 CASS R. LEWART'	
00750		END	DUB3	

and, if confirmed, is output at the end of the 1-ms interval that started at the beginning of the preceding clock pulse (Fig. 4).

A data pulse appearing any time between 500 µs and 1.2 ms after a clock pulse is thus correctly retimed to occur exactly 1 ms after the clock pulse. After a 100-µs delay, the program continues with the search for the next clock pulse. The DUB3 program can be loaded using the Radio Shack Editor/Assembler or by keying in the Z80 instructions. For a BASIC version of the DUB3 program which will POKE the instructions into memory see the Parts List.

Operating Instructions. The electrical interconnection between the Tape Regenerator, both tape recorders and the computer is shown in Fig. 5. Turn the computer and Tape Regenerator power off when plugging or unplugging the 40-pin connector at the rear of the TRS-80 keyboard.

If you have the Expansion Interface connected to your computer, use the Expansion Port on the left side of the Expansion Interface instead of the Expansion Port at the rear of the keyboard. When power is applied to computer and Tape Regenerator, *LED1* should glow and the MEMORY SIZE? prompt should appear on the video monitor. If the prompt does not appear, check connections, in particular the 40-pin connector, between the Tape Regenerator and TRS-80. Load the DUB3 program and run it. Light *LED3* (PGM ON) should glow as long as DUB3 is running. The program is in an infinite loop and will run until you depress the RESET pushbutton on the rear of the TRS-80, or turn the computer off.

For initial adjustment, start reading tape from tape recorder #1 and set polarity switch *S1* and the Tape Recorder volume control as explained under "Control Adjustments."

Rewind tape recorder #1 and start it in the play mode while starting tape recorder #2 in the record mode with a clean tape. When the program on tape recorder #1 is finished, *LED2* (VOL) will extinguish and meter *M1* will indicate close to zero. This is the signal for you to turn both tape recorders off. You can continue with as many tapes as desired. When finished, open *S2* to turn the Tape Regenerator power off, press the RESET button to return to BASIC, or turn the computer off. The 40-pin connector *P1* can be left plugged permanently into the Expansion Port as it does not interfere with the normal computer operation. If the pulse amplitude on the original tape is very unsteady or the pulses are imbedded in noise, regenerating the tape may not be possible. ◇