

ZX81 Assembly Instructions

U.S. Version for UHF Channel 33

Dear Kit Builder,

Congratulations on your purchase of a ZX81 computer kit. We are sure you will get a great deal of satisfaction in using a computer that you yourself built.

These instructions are largely a rehash of the ZX81 instructions supplied by Sinclair Research Ltd. Although Sinclair's instructions are complete, we feel the information is not given in the best format and the best sequence in which it is required when actually assembling your kit. So, mostly what we have done is present the same information in a linear fashion pointing out what you need to know in the order you need to know it.

If you have never soldered before, or built an electronics kit before, it would be best to seek the aid of someone with experience to help guide you. If you have even a moderate amount of experience, you should be able to assemble your kit in about three hours of easy work by just carefully following these instructions.

Happy kit building!

IMPORTANT:

Read through the instructions before you start assembly.

If anything seems unclear or difficult, contact us for advice before going ahead.

1. PREPARATION

You will need a clean, dry and well lit workspace in which to assemble your kit. If possible, try to find somewhere where the parts can stay undisturbed in case you do not finish the kit all at once. It is a good idea in any case to split the work up - say assemble the circuit board one evening, then test it and put the case together the next evening. You will need these tools:

(a) A light electric soldering iron, say 15 to 25 watts with a fine tip.

(b) Fine gauge solder with resin flux core; NOT acid flux.

(c) A pair of sharp sidecutters.

(d) A Philips head screwdriver with a No. 1 point.

(e) A medium size ordinary screwdriver.

The following items are optional, but useful;

(a) A magnifying glass for examining solder joints and looking for short circuits.

(b) Some desoldering braid or other solder removing tool. Better still, take care that you put the components in right the first time - removing them can be very difficult.

(c) A piece of foam is useful to stop components falling out when you turn the board over to solder them.

2. PRECAUTIONS

There are not many integrated circuits (IC's) in the kit, but they are all fairly expensive items and most of them are susceptible to damage from static electricity. There is no cause for worry if a few precautions are taken:-

(a) Use the sockets supplied with the kit - never solder the IC's direct to the board - and keep the IC's in their protective packing until you are ready to plug them in.

(b) Never insert or remove the IC's or do any soldering with power applied to the computer.

(c) Use a soldering iron with a properly grounded tip.

(d) Carpets and clothing of man-made fibres, and synthetic soles on shoes, are prone to building up a static charge. Ground yourself by touching a large object, preferably metallic, prior to touching the IC's. If you do get a shock, try changing your clothes.

(e) In general static electricity only becomes a problem when the air is dry, such as in the winter with hot air heating systems. A room humidifier will almost certainly cut down on static under these situations.

ZX81 KIT COMPONENTS LIST

Check	No.	Value	Markings	Comments
<u>RESISTORS</u>				
[]	R1	10K	Brown Black Orange	
[]	R2	680 ohm	Blue Grey Brown	
[]	R3	---	-----	Not Used
[]	R4	18K	Brown Grey Orange	
[]	R5	330	Orange Orange Brown	
[]	R6	2K2	Red Red Red	
[]	R7	470	Yellow Purple Brown	
[]	R8	470	" "	
[]	R9	470	" "	
[]	R10	470	" "	
[]	R11	470	" "	
[]	R12	470	" "	
[]	R13	470	" "	
[]	R14	470	" "	
[]	R15	220K	Red Red Yellow	
[]	R16	1K	Brown Black Red	
[]	R17	1K	" "	
[]	R18	1K	" "	
[]	R19	1K	" "	
[]	R20	1K	" "	
[]	R21	1K	" "	
[]	R22	1K	" "	
[]	R23	1K	" "	
[]	R24	1K	" "	
[]	R25	1K	" "	
[]	R26	1K	" "	
[]	R27	1K	" "	
[]	R28	680	Blue Grey Brown	
[]	R29	1M	Brown Black Green	The band may be yellow.
[]	R30	-----	-----	Not used
[]	R31	-----	-----	Not used
[]	R32	-----	-----	Not used
[]	R33	4K7	Yellow Purple Red	
[]	R34	220	Red Red Brown	
<u>RESISTOR PACKS</u>				
[]	No.	Value	Markings	Comments
[]	RP1	8 * 10K	10K	9 leads
[]	RP2	-----	-----	Not used
[]	RP3	5 * 10K	10K	6 leads
<u>CAPACITORS</u>				
[]	No.	Value	Markings	Comments
[]	C1	47pF	47	Ceramic disc
[]	C2	47nF	473 Z	" "
[]	C3	22uF	22u	Electrolytic 16V
[]	C4	47nF	473 Z	Ceramic disc
[]	C5	1uF	1u	Electrolytic 5V
[]	C6	100pF	100, 101, n10	Ceramic disc
[]	C7	47pF	47	" "

ZX81 KIT COMPONENTS LIST (continued)

[]	C8	47nF	473 Z	"	"
[]	C9	47nF	473 Z	"	"
[]	C10	10nF	10n, 103	"	"
[]	C11	47nF	473 Z	"	"
[]	C12	47pF	47	"	"

SEMICONDUCTORS

[]	IC1	Sinclair Logic IC	40 pins
[]	IC2	2364	24 pins
[]	IC3	Z80A or D780C1	40 pins
[]	IC4a-IC4b	PD2114LC	18 pins

* Some kits may have the following single IC instead of IC4a & IC4b.

[]	IC4	MK4118	24 pins
-----	-----	--------	---------

[]	REG	7805	5 Volt Regulator
[]	TR1	ZTX 313	
[]	TR2	ZTX 313	
[]	D1-D8	1N4448	Colors: Yellow, yellow, yellow, grey or Yellow, brown, yellow, grey or 1S44 2 Yellow bands

Some diodes may have their number printed on them instead.
* NOTE: D9 is not used.

[]	X1	CDA 6.5MC	3 lead ceramic filter.
-----	----	-----------	------------------------

OTHER COMPONENTS

- [] Modulator type UM1233
- [] Modulator trim (black card)
- [] 3 3.5mm jack sockets for power, ear and mic.
- [] 2 40-pin IC sockets
- [] either 2 24-pin IC sockets
- or 1 24-pin socket, and 2 18-pin sockets.
- [] KB1 5 pin keyboard connector
- [] KB2 8 pin keyboard connector
- [] Ready made flat keyboard
- [] Aluminium heatsink
- [] 4BA nut, bolt and washer for fixing regulator and heatsink
- [] Printed circuit board
- [] 2 Case halves
- [] 4 Rubber feet
- [] 3 Black (long) Philips head screws
- [] 4 Yellow (short) Philips head screws
- [] Sinclair or Timex power supply. 9Volts, 600 ma. min.

3. COMPONENT IDENTIFICATION

Before you start assembly, check the components against the component list and make sure you know what each part is. We have tried to cover all different markings of the components, but variations are possible.

Note in particular that the computer's memory may be supplied either as two 18 pin IC's (IC4a & IC4b) or as one 24 pin device (IC4), and that assembly is necessarily different for each version.

4. CIRCUIT BOARD ASSEMBLY

RESISTORS - There are 17 resistors that install vertically. These include:

 TABLE 1. Vertically Mounted Resistors

R7-R14	470 ohms (8 resistors)
R18-R26	1K ohms (9 resistors)

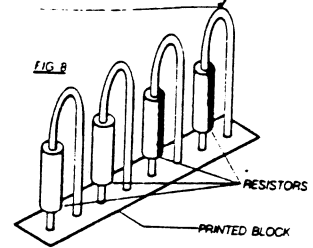

All the other resistors install horizontally and have their leads bent so that they fit into holes 0.5" apart.

NOTE: Resistors are not polarized components; it makes no difference which direction they are inserted into the printed circuit board.

We have found from experience, that the easiest way to build these kits is to first install some of the parts that lie flat, including the horizontally mounted resistors and diodes. This is because after inserting the components, the board can be turned over and still lie flat as you are soldering. Keeping this in mind, assemble your kit in the following sequence. Notice that we will save the vertically inserted resistors listed above in TABLE 1, until we have finished inserting the horizontal ones.

CHECK	No.	Values	Markings	Comments
[]	R1	10K	Brown Black Orange	
[]	R2	680 ohm	Blue Grey Brown	
[]	R3	-----	Not Used	
[]	R4	18K	Brown Grey Orange	
[]	R5	330 ohm	Orange Orange Brown	
[]	R6	2.2K	Red Red Red	

Resistors R7-R14 mount vertically and will be put in later.

[]	R15	220K	Red Red Yellow	
-----	-----	------	----------------	--

[] R16 1K Brown Black Red

[] R17 1K Brown Black Red

Resistors R18-R26 mount vertically and will be put in later.

[] R27 1K Brown Black Red

[] R28 680 ohm Blue Grey Brown

[] R29 1M Brown Black Green

Resistors R30, R31, and R32 are not used.

[] R33 4.7K Yellow Purple Red

[] R34 220 ohm Red Red Brown

DIODES.

There are 8 diodes, D1 thru D8. The diodes get inserted on 0.3" centers. The cathode ends have a band on them, or in some cases where the diodes have more than one band, the cathode is the side with the widest band. Insert the diodes into the board with the cathode ends corresponding to the flat bar symbols inked on the PC Board.

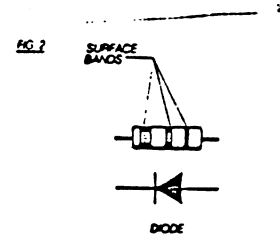

Figure 2.

[] D1 1N4148 Yellow Yellow Yellow Grey
or 1S44 2 Yellow Bands
Other marking possible.

[] D2 " "

[] D3 " "

[] D4 " "

[] D5 " "

[] D6 " "

[] D7 " "

[] D8 " "

[] D9 ----- Not used.

RESISTORS (Vertical Mounted)

Now that we have inserted all the low profile flush mounted components let us go back and finish up the resistors.

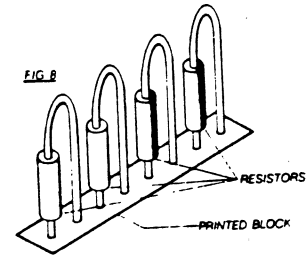

Figure 8.

There are four oblong boxes, (or rectangles), labelled R7-R10, R11-R14, R18-R22 and R23-R26. These all contain a row of resistors standing "on end" as in fig. 8. Take care when mounting these: use only the holes corresponding to the smaller box.

Four 470 ohm resistors R7-R10, get inserted vertically into an area marked on the PC board with a rectangle. See Fig. 8.

CHECK	No.	Values	Markings	Comments
[]	R7	470 ohm	Yellow Purple Brown	
[]	R8	"	"	
[]	R9	"	"	
[]	R10	"	"	

Four 470 ohm resistors R11-R14, get inserted vertically into an area marked on the PC board with a rectangle. See Fig.8.

[]	R11	470 ohm	Yellow Purple Brown	
[]	R12	"	"	
[]	R13	"	"	
[]	R14	"	"	

Five 1K resistors R18-R22 get inserted vertically into an area marked on the PC board with a rectangle. See Fig.8.

[]	R18	1K	Brown Black Red	
[]	R19	"	"	
[]	R20	"	"	
[]	R21	"	"	
[]	R22	"	"	

Four 1K resistors ^{R23-R26}~~R7-R10~~, get inserted vertically into an area marked on the PC board with a rectangle. See Fig.8.

[]	R23	1K	Brown Black Red	
[]	R24	"	"	

[]	R25	"	"
[]	R26	"	"

RESISTOR PACKS

The resistor packs (prefix RP) have a "common" end marked with a white dot. This should go at the end marked with a "C" on the board.

CHECK	No.	Values	Markings	Comments
[]	RP1	8 X 10K	10K	9 Leads
[]	RP2	-----		NOT USED
[]	RP3	5 X 10K	10K	6 Leads

CAPACITORS

The electrolytic capacitors (C3 & C5) will have a + or - symbol printed on them, and the + wire is usually longer. (See fig.3 and fig.7.).

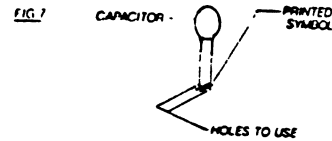
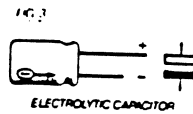

CHECK	No.	Values	Markings	Comments
[]	C1	47pF	47	Ceramic disk
[]	C2	47nF	473Z	"
[]	C3	22uF	22u	Electrolytic 16V
	* This part is polarized and must be properly oriented.			
[]	C4	47nF	473Z	Ceramic disk
[]	C5	1uF	1u	Electrolytic 5V
	* This part is polarized and must be properly oriented.			
[]	C6	100pF	100, 101, n10	Ceramic disk
[]	C7	47pF	47	"
[]	C8	47nF	473Z	"
[]	C9	47nF	473Z	"

[]	C10	10nF	10n, 103	"
[]	C11	47nF	473Z	"
[]	C12	47pF	47	"

TRANSISTORS

The transistors (prefix TR) go in the board as shown by the picture printed at their positions - i.e. with their rounded corners facing the edge connector.

[]	TR1	ZTX 313		Orient properly.
[]	TR2	ZTX 313		Orient properly.

CERAMIC FILTER

The ceramic filter is not polarized and may be inserted either way around.

[]	X1	Ceramic Filter		Not polarized.
-----	----	----------------	--	----------------

IC SOCKETS

The IC's have one end identified by a notch, and/or dimple next to pin 1. (See fig.1). Note that all the IC's face the same way on the board, i.e. with their notches toward the edge connector. Although the I.C. sockets do not need to go any particular way round, you may like to put the bevelled corner at the notch end of the I.C. position as a reminder, since the semicircle printed on the board will be covered by the socket in some cases.

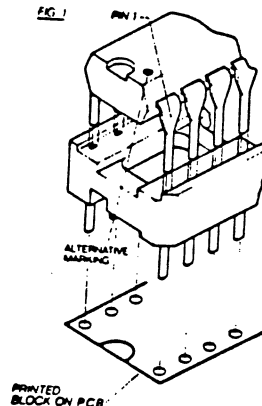

Figure 1.

There are 5 IC sockets that have been packaged along with the IC's in a special conductive foam. The foam protects the socket and IC leads from getting bent, and the conductive property of the foam keeps static electricity from destroying the IC's.

When you are ready to insert a socket into the printed circuit board, remove the socket from the foam carefully so as not to bend its leads.

CAUTION - Visually check that none of the leads are bent. If you find a bent lead, gently straighten it with a pair of needle nose pliers. Remember, the leads are brittle and can not be bent very much, before they will break. Do not insert a socket into the PC board unless all its pins are first seen to be straight. Then

carefully and gently align the socket with its marking on the PC board and insert it.

Visually check before you do any soldering, that all the leads come through the holes of PC board properly. If you start soldering and then notice you missed putting all the leads of the socket through the board it will be a lot of trouble to remove the socket.

It can be a bit tricky trying to keep an IC socket flush to the PC board when you turn it over for soldering. One method that works well is to use a small piece of masking tape to temporarily tape the socket to the board until its soldered. Whatever method you use it is recommended that you first solder just one or two pins on the socket and then visually check that the socket is flush to the board before proceeding with the other pins. If its not flush, reheat the one or two pins and make it flush before soldering the other pins.

[] IC1 Socket 40 pins

REMEMBER TO CHECK...

* Pin 1 orientation.

* All pins coming through PC board holes.

* Socket flush with PC Board.

[] IC2 Socket 24 pins

[] IC3 Socket 40 pins

[] IC4a Socket 18 pins

[] IC4b Socket 18 pins

REGULATOR

The regulator (REG) and heatsink need to go in a particular way round - just follow fig. 4.

*NOTE: If you are an experience kit builder and happen to have some heatsink thermal joint compound, it wouldn't hurt to put some between the regulator and the aluminum heat sink. This only becomes important if you add a number of peripherals to you computer, and this regulator is called upon to provide power for them.

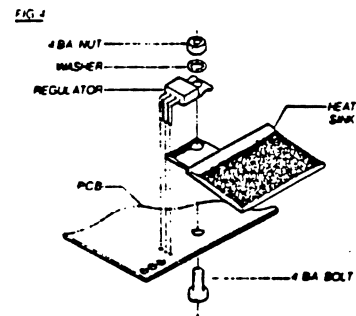

Figure 4.

CHECK	No.	Values	Markings	Comments
[]	REG	7805		5 Volt Regulator
[]		Aluminum Heat Sink		
[]*		*Optional heat sink thermal joint compound,(not supplied).		
[]	NUT	4BA		
[]	SCREW	4BA		
[]	WASHER	4BA		

JACKS

The jack sockets need to have their business ends (i.e. where the plug goes in) facing outwards, away from the components. This should be obvious by inspection of the board and case.

[]	J1	3.5mm	Power
[]	J2	3.5mm	Ear
[]	J3	3.5mm	Mic

UHF CHANNEL 33 TV MODULATOR

The modulator also needs to have its business end facing outwards, away from the components. This should be obvious by inspection of the board and case.

Put the modulator's wires through the holes marked "Fr/UK1" and "UK2". Put each lead through the hole it is nearest to: do not cross them over. Do not try to bend the thick pins on the modulator: hold it in place by hand while soldering. The black card trim is a push fit over the aerial socket.

[]	Modulator
[]	Modulator Trim (Black Cardboard)

VERY VERY IMPORTANT!
READ THIS BEFORE INSTALLING KEYBOARD CONNECTORS KB1 & KB2.

Two different brands of connectors have been used by Sinclair and there is an important difference between them.

BRAND 1 CONNECTORS - These are the original Sinclair connectors. If you align the connector within the printed rectangle on the PC board things will work out properly. See figure 12b.

BRAND 2 CONNECTORS - If you align these connectors according to the printed rectangles on the PC board you will be putting them in BACKWARDS! Figure 12c shows how to properly install the connectors if you have them in your kit.

CORRECT INSTALLATION of KB1 & KB2

With either brand of connector, proper installation of the connectors can be accomplished if you make sure the following holds:

- [] KB1 - Connector KB1 must have its contact springs away from the nearest PC Board edge.
- [] KB2 - Connector KB2 must have its contact springs nearest to the nearest PC Board edge.

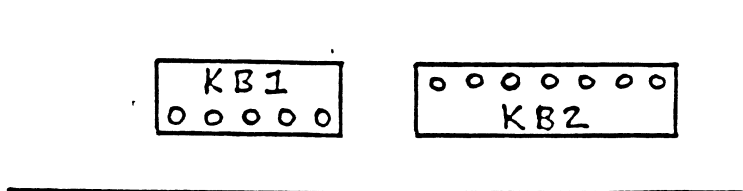

Figure 12a. Component side, bare ISSUE 1 ZX81 P.C. Board.

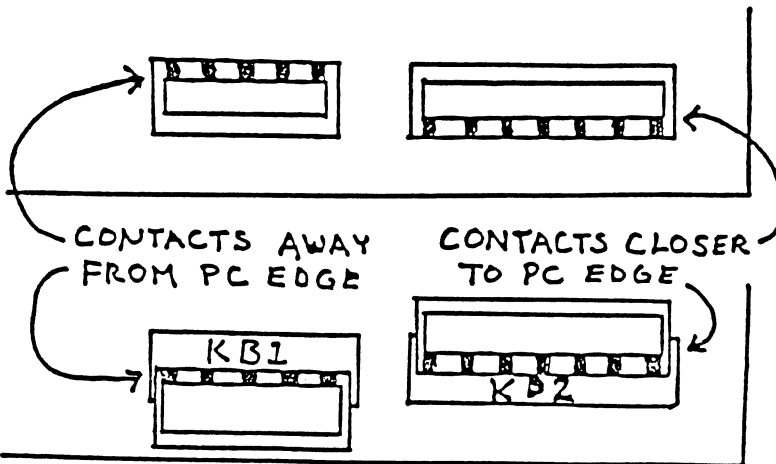

Figure 12b. Properly installed Brand 1 connectors.

Figure 12c. Properly installed Brand 2 connectors.

INTEGRATED CIRCUITS

The IC's have one end identified by a notch, and/or dimple next to pin 1. (See fig.1). Note that all the IC's face the same way on the board, i.e. with their notches toward the edge connector.

- [] IC1 Sinclair Logic IC, 40 PINS
- [] IC2 2364 ROM 24 PINS

*NOTE: IC2 has only 24 pins but it is being inserted into a 28 pin IC socket. Notice the printed marking on the printed circuit board. The IC should be inserted accordingly. Refer to fig.11.

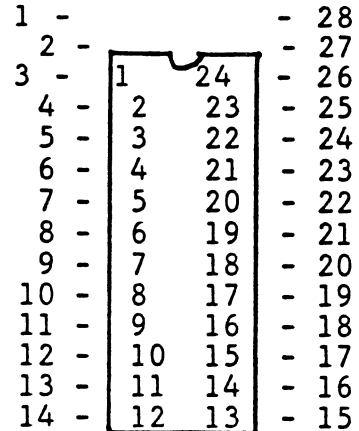
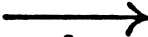

Figure 11. 
Shows the location of 24 PIN IC2 in 28 PIN socket.

- [] IC3 Z80A or D780C-1 microprocessor 40 pins
- [] IC4a,IC4b uPD2114LC RAM 18 pins

KEYBOARD & CASE

Refer to Sinclair Assembly Instructions Page 4, Sections 7i and 7ii.

- [] Membrane Keyboard
- [] Case Halves

NOTE: The following self-tapping screws require a Philips-head screw driver.

- [] 2 Yellow short screws For Mounting PCB
- [] 2 Yellow short screws For Case Halves
- [] 3 Black long screws For Case Halves
- [] 4 ADHESIVE RUBBER FEET

FIG 6

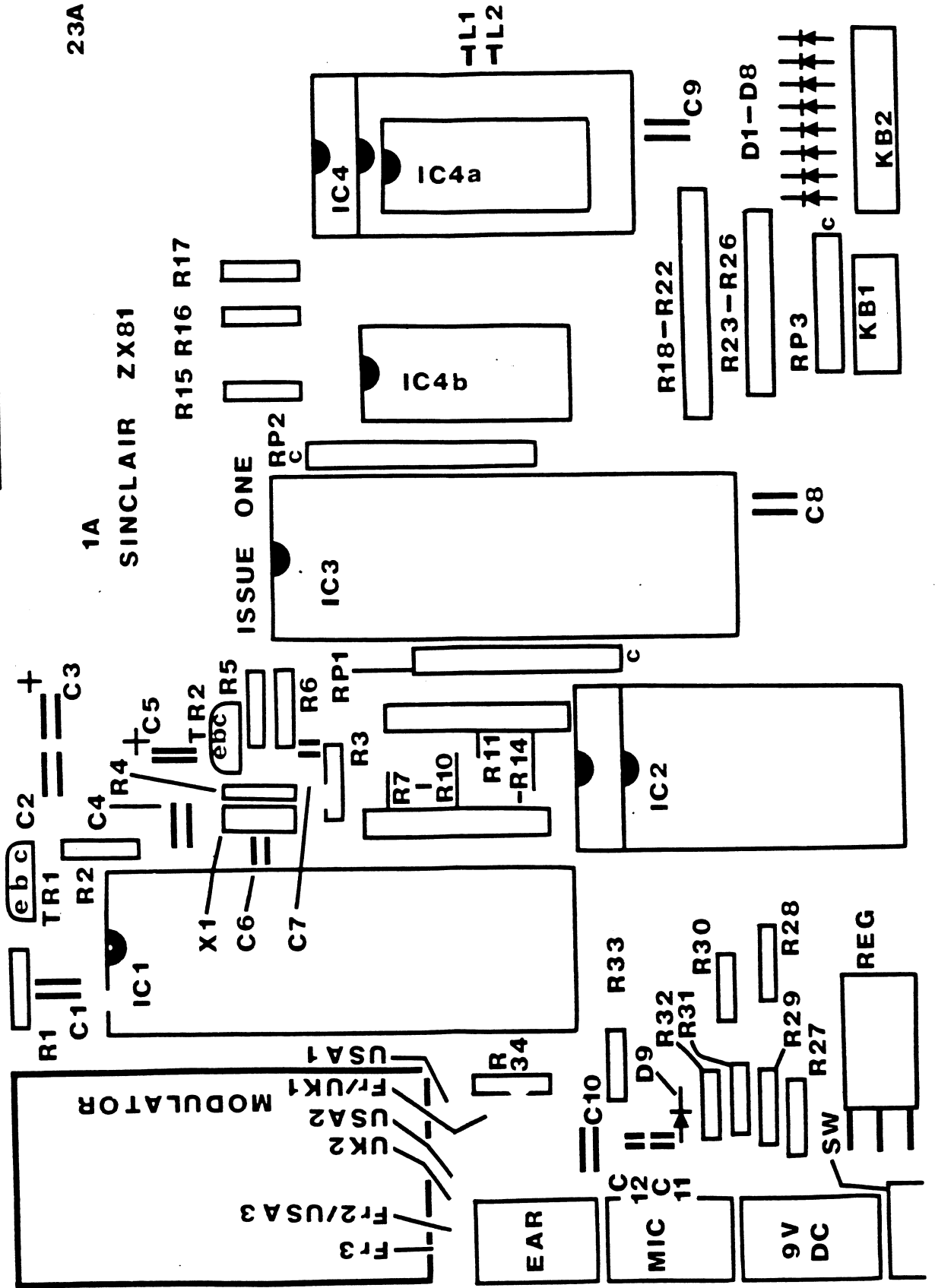

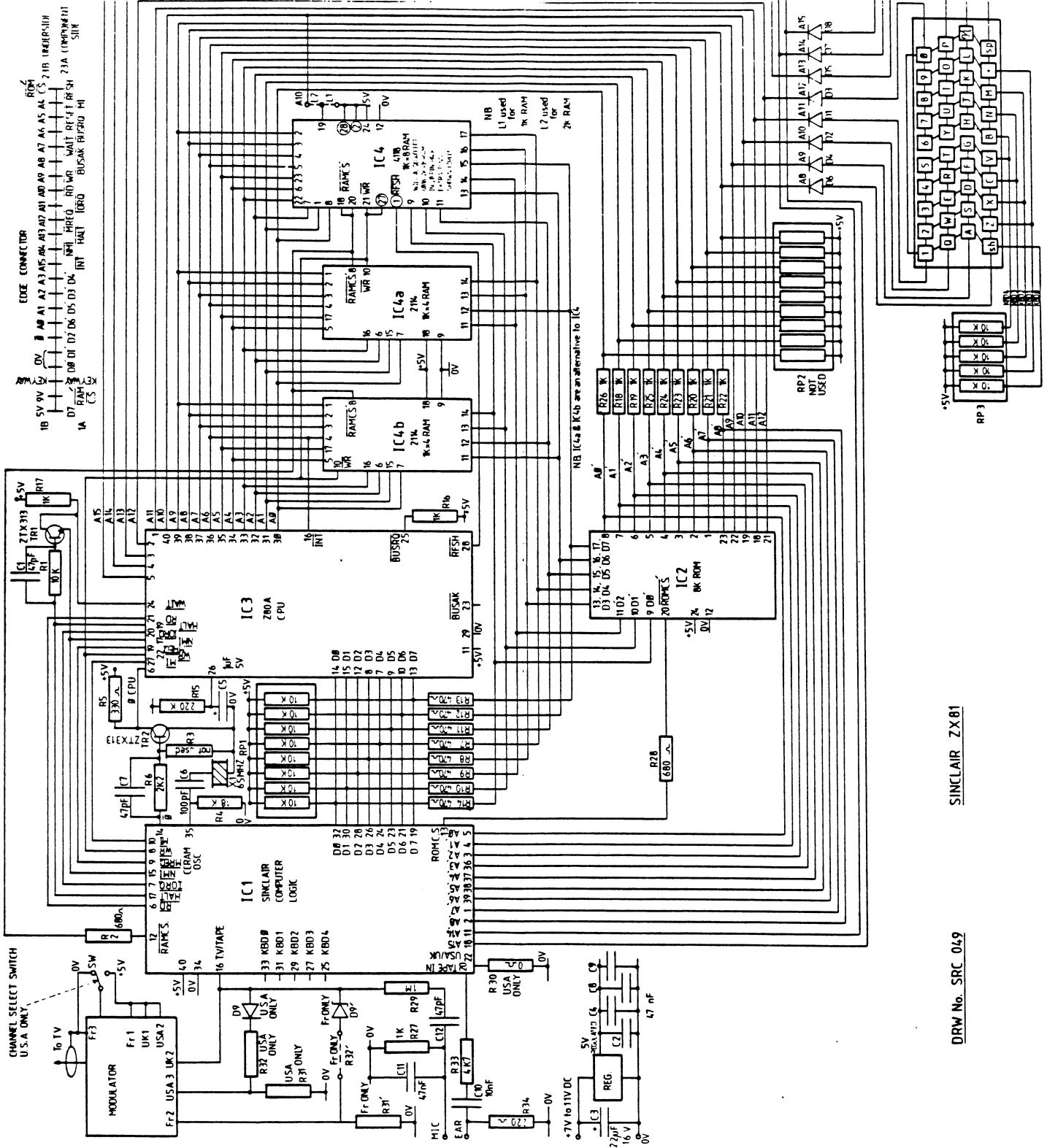

SINCLAIR ZX81

DRW No. SRC 049

**Sinclair UHF KITS Card Enclosure
for 60hz U.S.A. video**

This package contains an extra component necessary for the assembly of this kit. It is R30, a 0.5 in. jumper wire. Insert this component at the position marked R30 on the PCB. Be very careful in the placement of this jumper. There are three holes to the left of the box marked R30. Insert the jumper into the middle one of these. This jumper selects 60hz video as opposed to the normal U.K. 50hz.

Insert the UHF modulator following the instructions given in the Assembly Instructions leaflet. Be sure to insert the two wire leads into the holes marked "Fr/UK1" and "Fr/UK2". These are in effect the UHF locations for the modulator. (Disregard the USA openings on the PCB.)

**TO OBTAIN VIDEO DISPLAY
TUNE TV BETWEEN CHANNELS 30-40**