

OPERATION MANUAL

SCT-100

Single Card Video Terminal

XITEX

P.O. Box #20887
Dallas, Texas 75220

XITEX
SCT-100 SERIES
ASSEMBLY / OPERATIONS
MANUAL

Rev. 1, 7-15-77

WARRANTY REGISTRATION

In order to validate your Xitex Warranty this registration form must be filled out within ten (10) days from the date of purchase and returned to the following address:

XITEX CORP.
Service Department
P.O. Box 20887
Dallas, Texas 75220

Purchase Date _____ Company _____

Name _____ Street Address _____

City _____ State _____ Zip _____

Phone Number () _____ Extension _____

Type of Purchase

_____ Direct Mail _____ Computer Store : _____

Equipment Covered under this Warranty _____ SCT-100P
_____ SCT-100K
_____ SCT-100A

Intended Application:

_____ Personal Computing

_____ Commercial

_____ Amateur Radio

Intended Installation Configuration:

_____ S-100 Computer: Type _____

_____ Stand Alone

What new products would you be interested in? _____

ELECTRICAL SPECIFICATIONS

Power

7 - 11 VDC @ 0.75 A Max unregulated
or
8 - 12 VAC rms @ 0.75 A Max
or
5 VDC 5% @ 0.75 A Max regulated

Serial I/O

20 ma full duplex (180 V max)

60 ma Simplex (180 V max)

EIA RS232 Modified (Xmit TTL levels)

Keyboard

6 or 7 bit ASCII TTL compatible.
positive true logic for Data and
Strobe. 5V @ 250 ma max
supplied by SCT-100.

ASSEMBLY AND OPERATIONS MANUAL - SCT-100

1. INTRODUCTION

The SCT-100 represents the state-of-the-art in video terminal designs. It provides more on-board features with fewer components than has ever been possible in the past. It is offered from XITEX in three basic configurations, all of which are described in detail in this manual. To ensure that no difficulties are encountered with the operation of this equipment, the owner should carefully read and adhere to all the instructions contained in each of the following sections. By doing so, the owner will be assured years of trouble free operation.

2. ASSEMBLY INSTRUCTIONS (SCT-100 PARTIAL KIT)

2.1 Additional Components Required

For those SCT-100 owners who have purchased the partial kit (SCT-100P), only those components indicated with "Note #6" in the parts list (Table 3.1) have been included. The remaining items in the parts list should be readily available from a local electronic components distributor. Before purchasing these additional components, however, the owner should carefully read all the notes at the end of Table 3.1 and be aware that any substitution of unspecified devices for those specified in the parts list will void the warranty on the board. This particularly applies to the substitution of 'standard' parts for the specified 'low power' parts (e.g. substituting a 7400 for a 74LS00, or a 2102 for a 21L02). This restriction is necessary to insure that the power limitations of the on-board regulator are not exceeded.

2.2 Step by Step Assembly

Once the additional parts required to assemble the SCT-100 have been purchased (in accordance with the preceding section) the step-by-step assembly may begin. Since the assembly instructions for the SCT-100P (Partial Kit) are identical to those for the SCT-100K (Full Kit) the reader is referred to the assembly instructions in Section #3.

3. ASSEMBLY INSTRUCTIONS (SCT-100 COMPLETE KIT)

3.1 Unpacking Instructions

The SCT-100 contains all the components necessary to assemble a complete SCT-100 single card terminal. These components are listed in Table 3.1, and the owner of the SCT-100K should check to see that all parts have been received before proceeding. In the unlikely event that any deficiencies are discovered, the Service Department should be notified as specified in Section 4.9.

3.2 Assembly Precautions

The SCT-100 circuit board has been designed and laid out in such a way that anyone who is reasonably adept at soldering components on a printed circuit board should have little difficulty assembling it. Persons attempting to assemble this kit without any previous experience, however, should seek assistance.

CAUTION

The MOS integrated circuits supplied in this kit are subject to damage from static electric discharge due to improper handling. They have been protected during shipment by conductive foam pads or tubes from which they should not be removed until they are ready to be installed on the circuit board. Additional precautions should include 'grounding' the soldering iron and operator during installation, particularly if the environment is likely to permit accumulations of static electricity due to low humidity, carpets, etc..

CAUTION Use Rosin Core solder when soldering components into the SCT-100
Use of Acid Core solder or Acid solder flux will void the warranty.

3.3 Step-by-Step Assembly

Important

All sockets and integrated circuits must be oriented such that pin #1 is positioned as shown in the assembly drawing. Failure to do this can cause component damage. It is also a difficult error to correct since circuit board damage frequently occurs when it is necessary to unsolder integrated circuits. Electrolytic capacitors, diodes, and transistors are also subject to being improperly oriented, and extra care should always be taken when inserting these components. In short, take your time and be careful - it will undoubtedly save considerable time in the long run.

In the steps below, install the components in the sequence indicated, checking off each component in the parts list (Table 3.1) as it is installed. Use the SCT-100 assembly drawing to determine the location and orientation for installing each component.

Steps:

1. Install 16 pin dip sockets at XJ2 and XJ3.
2. Install 24 pin and 40 pin dip sockets at XU9 and XU10 respectively.
3. Install resistors R1 through R24 at the positions indicated. Be sure to check off each resistor in the parts list as it is installed, and check to be sure that the proper value is selected. All leads should be clipped off close to the solder side on these and other components after they have been soldered in.
4. Install the fourteen .01 mfd ceramic capacitors at locations C5 through C17 inclusively, and at location C2. Any orientation is acceptable.
5. Install the 33pf capacitor at location C3. Any orientation acceptable.
6. Install the 300 mfd electrolytic capacitor at C1, being careful to observe the specified orientation of the '+' and '-' terminals as shown in the assembly drawing.
7. Install the 1000 mfd, 25V electrolytic capacitor at C4 per the specified orientation on the assembly drawing. NOTE: The P.C. Board is layed out to accept capacitors with either axial or radial leads as shown in the diagram. Polarity must be observed in either case, however.
8. Install the 10 mfd, 10V electrolytic capacitor at C18 per the specified orientation on the assembly drawing.
9. Install the two 47 mfd electrolytic capacitors at locations C19 and C20, observing the specified orientation.
10. Bend the leads of the LM340T-5 so that when inserted in location U22 the large hole in the tab is aligned with the large mounting hole in the PCB. Using the thermal compound provided, apply a liberal coating to both sides of the LM340 tab and the bottom side of the larger section of the heat sink. This larger section lays on the circuit board, the LM340T fits on top of the larger section, and the smaller heatsink section fits on top of the of the regulator tab. The 4-40 screw then fits through the tab, both sections of the heat sink, and the PCB after making the assembly as described above. The entire assembly must be screwed down before the regulator leads are soldered in place.
11. Install the Diodes CR1 through CR11 observing polarity indicated. The arrow points towards the banded end. CR3,4,5 & 6 may be replaced by a single full wave bridge module such as the Radio Shack RS-1151.
12. Install transistors Q1 through Q5 observing both type and polarity.
13. Install 31 integrated circuits (U1 through U21, and U23 through U32) observing both type and orientation. All IC's have the same orientation. Viewed as seen in the assembly drawing pin #1 is in the lower right corner indicated by a dot printed on the PCB. Install U9, U10, and U23 through U29 last.

TABLE 3.1

Item	Description	Manufacturer	Part Number	Notes
C1	CAP,300 uf, 3V Electrolytic	Sprague	500D-307G003DC7	
C2	CAP,0.1 uf, 50V Ceramic	Erie	8101-0506510102M	
C3	CAP, 33pf, 500V Mica	Arco	ADM-15-330J	
C4	CAP,1000uf, 25V Electrolytic	CEW	1000/25	1,5
C5-C17	CAP,0.1uf, 50V Ceramic	Erie		
C18	CAP,10mfd, 10V, Electrolytic	Sprague	500D-106G010BA7	
C19,C20	CAP,47uf,25V Electrolytic	Sprague	503D-476G025CB	
CR9-11	Diode,Silicon,1N914	TI	1N914	
CR1	Diode,Silicon,1N4004	TI	1N4004	
CR2	Diode,Silicon,1N4004	TI	1N4004	
CR3-CR6	Diode Bridge,4-1N4004	TI	1N4004	4,5
CR7	Diode, Silicon, 1N914	TI	1N914	
CR8	Diode, Silicon, 1N914	TI	1N914	
R1	Res., 5600 ohm, 1/4 watt	(GRN-BLU-RED)		
R2	Res., 5600 ohm, 1/4 watt	(GRN-BLU-RED)		
R3	Res., 2200 ohm, 1/4 watt	(RED-RED-RED)		
R4	Res., 51 ohm, 1/4 watt	(GRN-BRN-BLK)		
R5	Res., 1000 ohm, 1/4 watt	(BRN-BLK-RED)		
R6	Res., 680 ohm, 1/4 watt	(BLU-GRY-BRD)		
R7	Res., 680 ohm, 1/4 watt	(BLU-GRY-BRN)		
R8	Res., 1000 ohm, 1/4 watt	(BRN-BLK-RED)		
R9	Res., 10,000 ohm, 1/4 watt	(BRN-BLK-ORG)		
R10	Res., 1 Meg ohm, 1/4 watt	(BRN-BLK-GRN)		
R11	Res., 15000 ohm, 1/4 watt	(BRN-GRN-ORG)		
R12-R16	Res., 3300 ohm, 1/4 watt	(ORG-ORG-RED)		
R17	Res., 270 ohm, 1/4 watt	(RED-VIO-BRN)		
R18	Res., 3300 ohm, 1/4 watt	(ORG-ORG-RED)		
R19	Res., 3300 ohm, 1/4 watt	(ORG-ORG-RED)		
R20	Res., 1000 ohm, 1/4 watt	(BRN-BLK-RED)		
R21	Res., 470,000 ohm, 1/4 watt	(YEL-VIO-YEL)		
R22	Res., 220 ohm, 1/4 watt	(RED-RED-BRN)		
R23	Res., 4700 ohm, 1/4 watt	(YEL-VIO-RED)		
R24	Res., 4700 ohm, 1/4 watt	(YEL-VIO-RED)		
Q1	Tran., Silicon NPN, 2N3904	TI	2N3904	
Q2	Tran., Silicon NPN, 2N3904	TI	2N3904	
Q3	Tran., Silicon PNP, MPSA92	Motorola	MPSA92	
Q4	Tran., Silicon NPN, 2N3904	TI	2N3904	
Q5	Tran., Silicon NPN, TIS-100	TI	TIS-100	
U1	IC, 5-Bit Shift Register	TI	74LS96	
U2	IC, Synchronous 4-Bit Counter	TI	74LS163	
U3	IC, Hex Inverter	TI	74LS04	
U4	IC, Synchronous 4-Bit Counter	TI	74LS163	
U5	IC, Divide by 12 Counter	TI	74LS92	
U6	IC, Triple 3-input Nand	TI	74LS10	
U7	IC, Non-inverting Hex Buffer	TI	8097	2
U8	IC, Opto-isolator	Optron	OPI-2150	
U9	IC, Character Generator ROM	Xitex	U-3401	6
U10	IC, Custom 3870 Microprocessor	Xitex	U-7001	6
U11	IC, 4-Bit Binary Full Adder	TI	74LS83	

TABLE 3.1 (Continued)

U12	IC, Synchronous 4-Bit Counter	TI	74LS163	
U13	IC, Quad Exclusive Nor, O.C.	TI	74LS266	
U14	IC, Quad 2-input And	TI	74LS08	
U15	IC, Non-inverting Hex Buffer	TI	8097	2
U16	IC, Opto-isolator		OPI-2150	
U17	IC, Hex D Flip-flop	TI	74LS174	
U18	IC, Hex D Flip-flop	TI	74LS174	
U19	IC, Synchronous 4-Bit Counter	TI	74LS163	
U20	IC, Quad Exclusive Nor, O.C.	TI	74LS266	
U21	IC, Quad 2-Input Nor	TI	74LS02	
U22	IC, Regulator, 5VDC @ 1Amp	National	LM340T-5	
U23-U29	IC, 1K x 1 Static RAM	Intel	21L02	
U30	IC, Triple 3-input Nand	TI	74LS10	
U31	IC, Quad Exclusive Nor, O.C.	TI	74LS266	
U32	Quad 2-input Nand	TI	74LS00	
Y1	Crystal	Xitex	Y-100	6
XJ1	Connector, Card Edge, 30 Pin .156			
XJ2	Socket, 16 Pin DIP, solder Tail			
XJ3	Socket, 16 Pin DIP, Solder Tail			
XU9	Socket, 24 Pin DIP, Solder Tail			6
XU10	Socket, 40 Pin DIP, Solder Tail			6
HU22	Heat Sink, Tab Mount	Thermalloy	THM-6071,2B	3,6
	Heat Sink Hardware			
-	#4 Star Washer			
-	#4-40 Hex Nut			
-	#4-40 X 3/8" machine Screw			
-	Thermal Heatsink Lubricant			6
PCB-1	Circuit Board, SCT-100	Xitex	B-100	6

NOTES:

- 1) For proper mounting C4 must have a physical length of not more than 1.5 inches. If desired, an equivalent value capacitor with radial leads may be substituted using the alternate pads and tie-down holes provided on the PC Board.
- 2) For interfacing with ASCII encoded Keyboards having negative true strobe and data lines, the 8097 Hex Buffers (Non-inverting) at U7 and U15 must be replaced with 8098 Hex Buffers (Inverting). All SCT-100 kits and Assembled units are shipped with 8097 buffers only.
- 3) The heatsink is an assembly of two components which must be used together. (THM6071B and THM-6072B)
- 4) The PC Board is layed out to accept either four individual diodes or a full wave bridge module such as the Radio Shack #RS-1151 or equivalent.
- 5) These components are required in stand-alone applications only and may be omitted in S-100 type applications.
- 6) Components supplied in partial kit.

4. SCT-100 INSTALLATION AND CHECKOUT PROCEDURES

This section deals with each option and each element of the hook-up separately, that is: power supply; monitor; keyboard; and serial interface options are discussed in detail separately. Then the hook-up and checkout of the system as a whole functional unit is discussed.

4.1 Equipment needed (not supplied)

1. A Video Monitor such as the Sanyo model VM4092 or equivalent or a television set modified to accept standard EIA composite video signals.

2. A +5V only positive true logic ASCII encoded keyboard, such as the Cherry model B70-4753.

Note: This keyboard will work for either the ASCII or the Baudot operation modes of the SCT-100.

3. A Mini/Micro Computer having a serial I/O port configured for either TTL, EIA voltage level switching or full Duplex or Simplex current loop interface. (this is not required for TV Typewriter operation).

4. A power supply hookup consisting of one of the following:

A. An S-100 type bus system providing +7V to +10V unregulated DC.

B. An 8V AC transformer.

C. A 12.6V AC transformer and a 4 ohm 10 watt resistor.

D. +5V 5% @ 1.0 Amp regulated DC power supply.

5. A 30 pin 156 mil on center card edge connector such as the Amphenol model 225-21521-101, or two 16 pin DIP flat cable connectors, or two 16 pin DIP component carriers.

6. Wire and/or flat cable to complete hookup.

4.2 Power Connection, Options

4.2.1 The S-100 Bus System

To power the SCT-100 from your S-100 bus system the SCT-100 need only be inserted into one of the card cage sockets in the S-100 system and a jumper placed from E3 to E4. The SCT-100 will use the +7V to +10V DC unregulated S-100 power supply. NOTE: Positive voltage should be on pins 1 and 51 and Ground on pins 50 and 100.

4.2.2 Operation with an External Transformer

The SCT-100 will operate from the secondary of an 8V transformer or from a 12.6V transformer plus a dropping resistor. The transformer and the dropping resistor must be connected as shown in figure 4.1. The 3-4 ohm, 10w dropping resistor must be in series with the transformer secondary.

4.2.3 Operation with a Regulated DC Power Supply

To operate the SCT-100 from a regulated +5V 5% @ 1.0A DC Power Supply, the jumper between E3 and E4 must be removed. The positive side of the power supply must be connected to pins 1 and 51 on the card edge connector and a jumper connected between E4 and E5. The ground side of the power supply must be connected to pins 50 and 100. In stand alone operation the jumper may be omitted and the positive voltage brought directly to the PC Board pad marked E4.

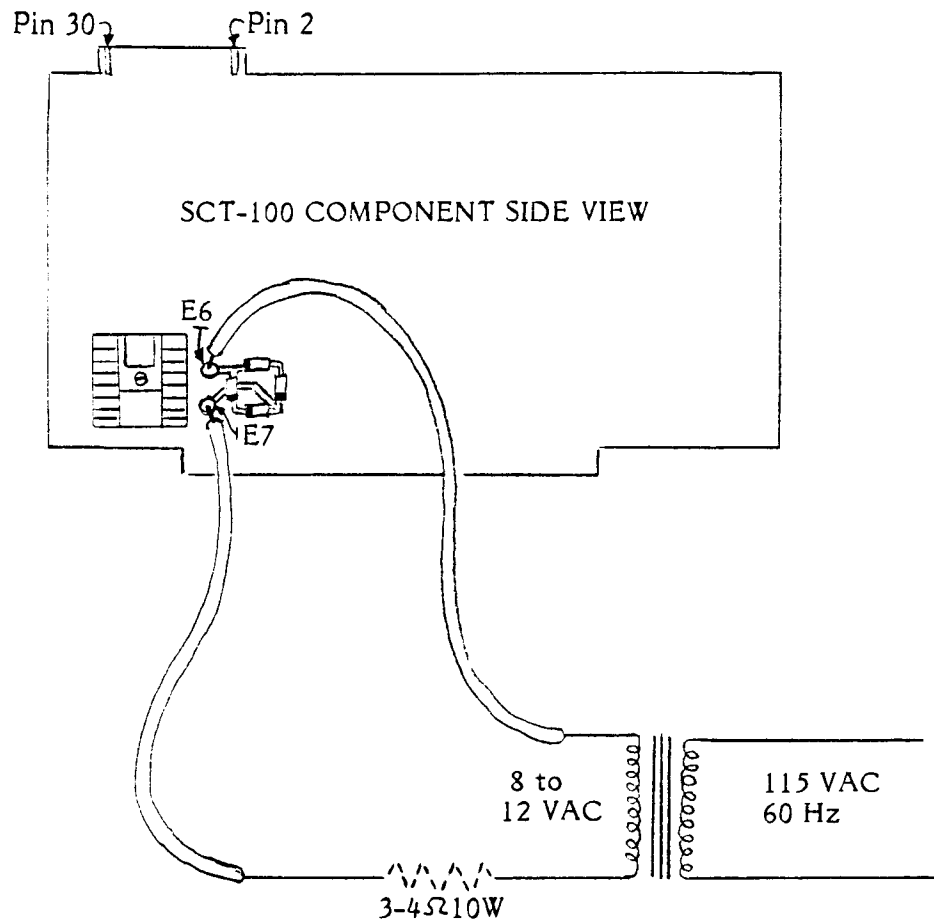

Figure 4.1
Operation of the SCT-100 from an AC Transformer

NOTE: The dropping resistor is only required when using the common 12.6VAC filament transformer. When using an 8VAC transformer this resistor may be omitted.

4.3 Attachment to the Video Monitor

The connection to the Video Monitor is to be made through points E1 and E2 on the SCT-100. Pad E1 is the EIA composite video output and pad E2 is the common ground point. Connection must be made in the following manner:

1. Solder wires into the plated through holes identified as E1 and E2.
2. If a commercial video monitor such as the Sanyo model VM4092 or equivalent is to be used, the wire from E1 must be routed into the center conductor of the UHF connector. This can best be accomplished by terminating the wires from E1 and E2 to a mating UHF connector such as the Amphenol model PL259, taking care that the wire from E1 is routed to the center post of the connector.
3. A television set suitably modified to accept standard EIA composite video can be used as a monitor and may be connected to the SCT-100 in a manner similar to that discussed for a commercial monitor, with the video output (E1) connected to the input of the first video amplifier stage of the television set and the ground (E2) connected to the ground (zero volts) of the television set.

CAUTION

When a modified commercial TV receiver is being used as a monitor, extreme care should be exercised since some receivers do not have a transformer type power supply. This can result in the TV chassis 'ground' being 120V AC 'hot' relative to earth ground.

4.4 Keyboard Connection

A +5V only, positive true logic, ASCII encoded keyboard, such as the Cherry B70-4753 or equivalent must be connected to the edge connector J1 in the following manner:

Keyboard Function		J1 Connector Pin #	
+5V	(5)	2 & 4	
Ground	(8)	1 & 3	
Data Bit 0	(15)	13	NOTE: Parenthetical numbers denote pin numbers on the Cherry model B70-4753 keyboard.
Data Bit 1	(14)	15	
Data Bit 2	(13)	17	
Data Bit 3	(12)	19	These connections may alternately be made through the 16 pin socket labled J2.
Data Bit 4	(10)	21	Check the schematic for the appropriate J2 pin numbers.
Data Bit 5	(11)	23	
Data Bit 6	(9)	25	
Strobe	(6)	27	

CAUTION: If the keyboard used requires more than 250ma at 5V, or if the keyboard requires a voltage different than +5V, the keyboard must be externally powered. In this event the external power supply ground must be hooked to the ground or zero voltage point of the SCT-100.

4.5 Serial Interface Options

4.5.1 Baud Rate and ASCII/Baudot Selection

The SCT-100 will operate as either an ASCII or a Baudot terminal at the following baud rates: 110 or 300 baud ASCII, or 45.45 or 74.2 Baudot. The strapping connections for these options are located on the 30 pin J1 connector. The various options are obtained by either grounding or leaving open the particular pins on the card edge connector. J1 pin #10 controls the mode (ASCII or Baudot) of operation. When pin#10 is open the SCT-100 is in the ASCII mode. When pin#10 is grounded (i.e. connected to J1 pins 1 & 3), the SCT-100 will accept serial Baudot information from the current loop and display it on the screen and will accept information from the ASCII keyboard and output it in serial Baudot code to the current loop interface.

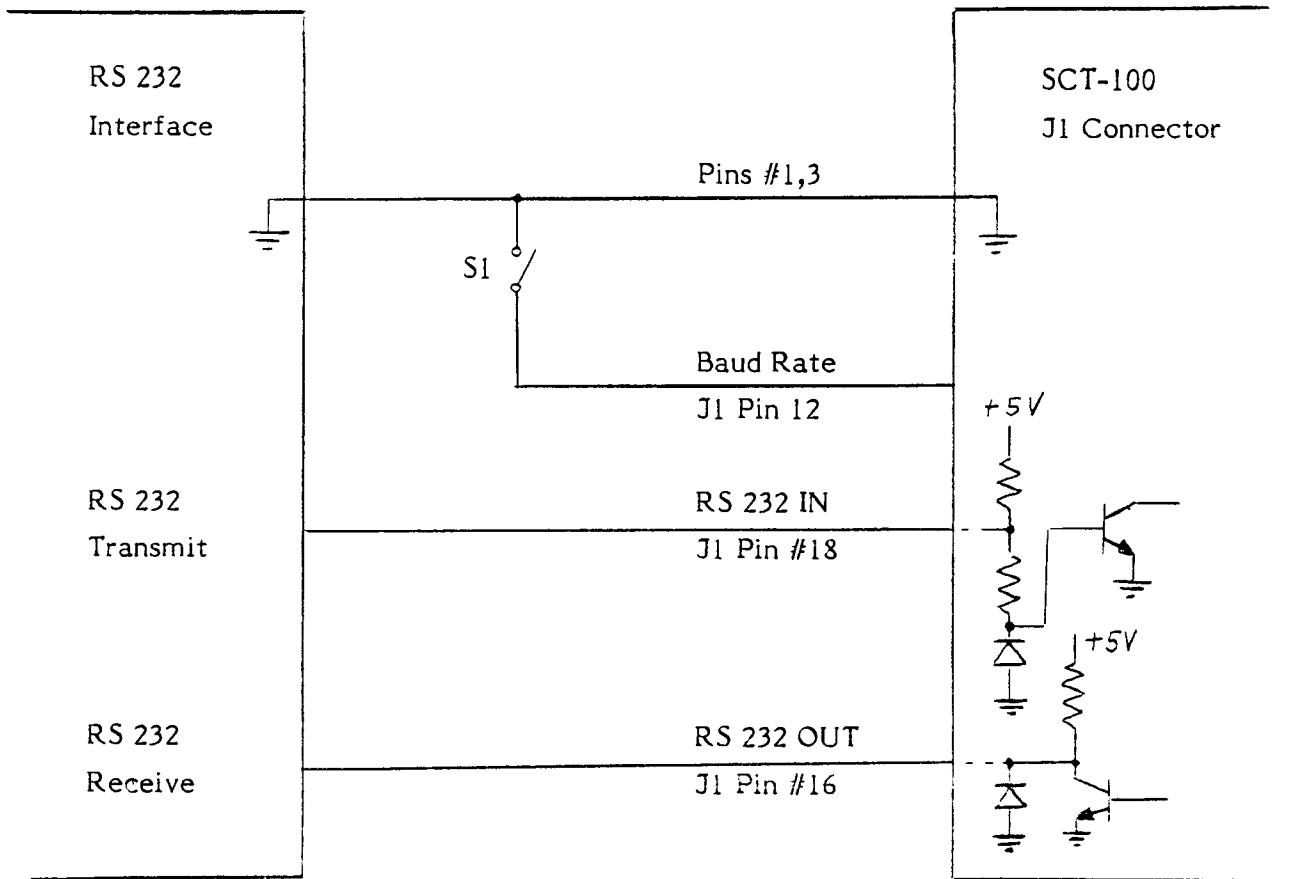

S1 Open = 300 Baud
 S1 Closed = 110 Baud

TTL/EIA 3 wire hook-up

Figure 4.3

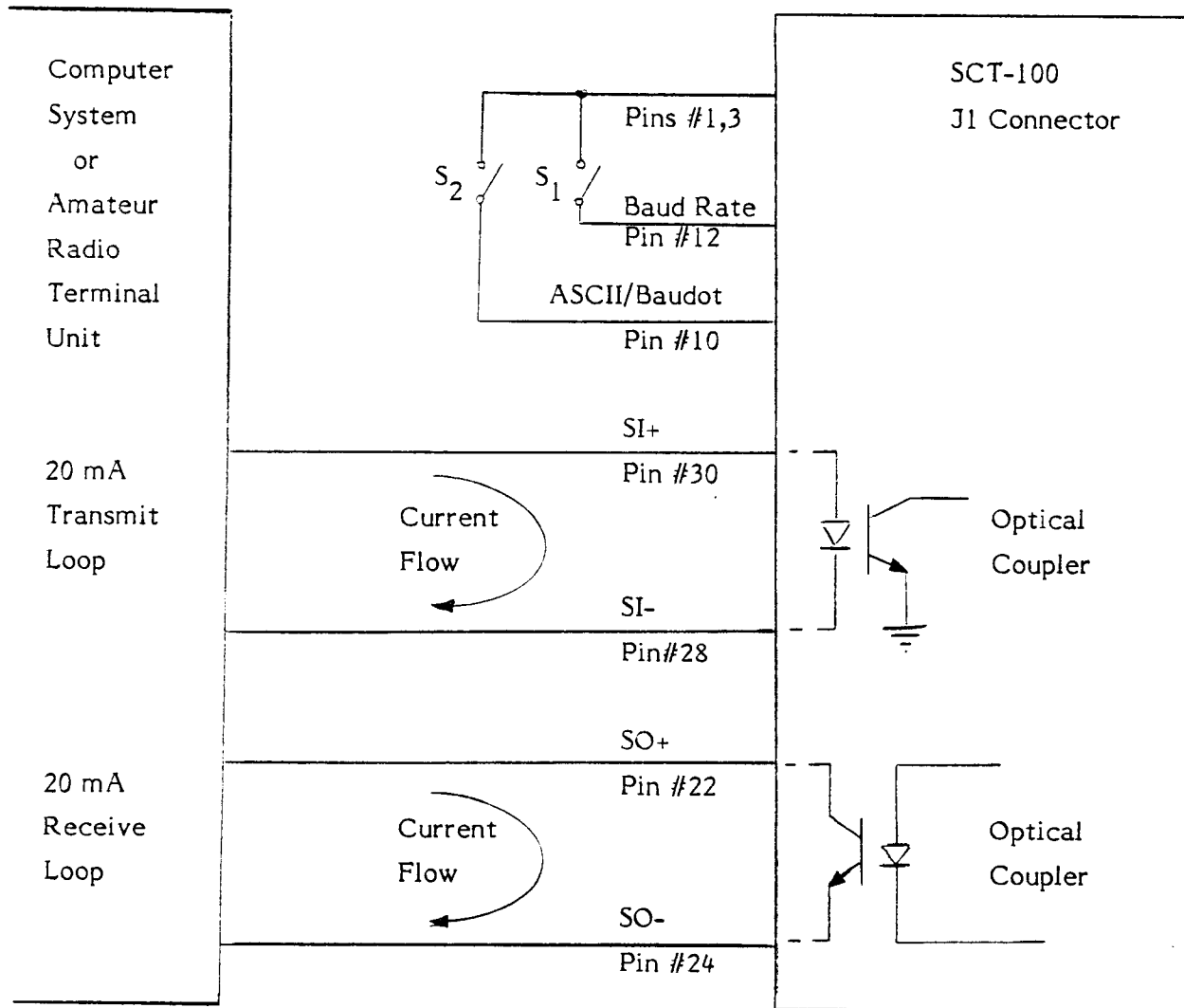

- S1 Open = High Baud Rate (300 Baud ASCII or 74.2 Baud Baudot)
- S1 Closed = Low Baud Rate (110 Baud ASCII or 45.45 Baud Baudot)
- S2 Open = ASCII Operation
- S2 Closed = Baudot Operation

FULL DUPLEX CURRENT LOOP HOOKUP

Figure 4.4

J1 pin 12 controls the selection of the terminal Baud rate. When pin 12 is open the high Baud rate (300 Baud ASCII or 74.2 Baud Baudot) has been selected. When pin 12 is grounded (i.e. tied to J1 pins 1&3) the low Baud rate (110 Baud ASCII or 45.45 Baud Baudot) has been selected.

<u>Pin 10</u>	<u>Pin 12</u>	<u>Mode</u>
open	open	300 Baud ASCII
open	Grounded	110 Baud ASCII
Grounded	Open	74.2 Baud Baudot
Grounded	Grounded	45.45 Baud Baudot

Note: In the Baudot mode the SCT-100 will accept inputs from the current loop in Baudot code and from the keyboard in ASCII code. It is never necessary to purchase a Baudot keyboard.

4.5.2 Simplex, Duplex, and EIA.TTL Interface Options

The SCT-100 has been configured to operate with virtually any computer system having a serial I/O port with either TTL/EIA voltage level signaling or a full Duplex current loop or a Simplex current loop interface. The methods of connecting the SCT-100 to these three types of interfaces are discussed below.

NOTE: In this section pin numbers refer to the pins of the SCT-100 card edge connector J1 unless otherwise specified.

CAUTION: Before attempting to hook up your computer, amateur radio terminal unit, Teletype system, or modem to the SCT-100, determine which of the following three types of interface is required.

- A. TTL/EIA voltage level switching, i.e. 3 wire hookup
- B. Full Duplex 20 ma current loop switching, i.e. 4 wire hookup
- C. Simplex 60ma current loop switching, i.e. 2 wire hookup

For systems having the TTL/EIA voltage switching interface, the voltage levels may not exceed +12V (positive) or -12V (negative) with respect to ground. For systems having either Duplex or Simplex current loop switching, the maximum voltage may not exceed 180V and the maximum current may not exceed 70ma.

4.5.2.1 TTL/EIA Voltage Level Switching (3 wire hookup)

Refer to Figure 4.3

For TTL/EIA voltage level switching between the SCT-100 and a computer, the signal "RS 232 in", (pin 18) from the SCT-100 must be connected to the "RS 232 out" signal from the computer. The signal "RS 232 out" (pin 16) from the SCT-100 must be connected to the "RS 232 in" signal from the computer. The ground pins (1&3) from the SCT-100 must be connected to the computer ground. With these connections, the SCT-100 will transmit TTL level signals and will receive full EIA level signals.

4.5.2.2 Duplex Current Loop Connection (4 wire hookup)

Refer to Figure 4.4

Many small computers have a full duplex current loop interface used to communicate with a Teletype. The SCT100 has a full Duplex, fully isolated current loop interface that allows the SCT-100 to replace a Teletype. To connect the SCT-100 to the computer, a 4 wire hookup must be made connecting the current loop transmit section of the computer to the current loop receiver section (SI+ = pin 30 and SI- = pin 28) of the SCT-100, and the current loop receiver section of the computer to the transmit section (SO+ = pin 22 and SO- = pin 24) of the SCT100.

NOTE: Current flows into both SO+ (Pin 22) and SI+ (pin 30).

Current flows out of both SO- (pin 24) and SI- (pin 28).

CAUTION: Maximum Voltage = 180V, Maximum Current = 70ma.

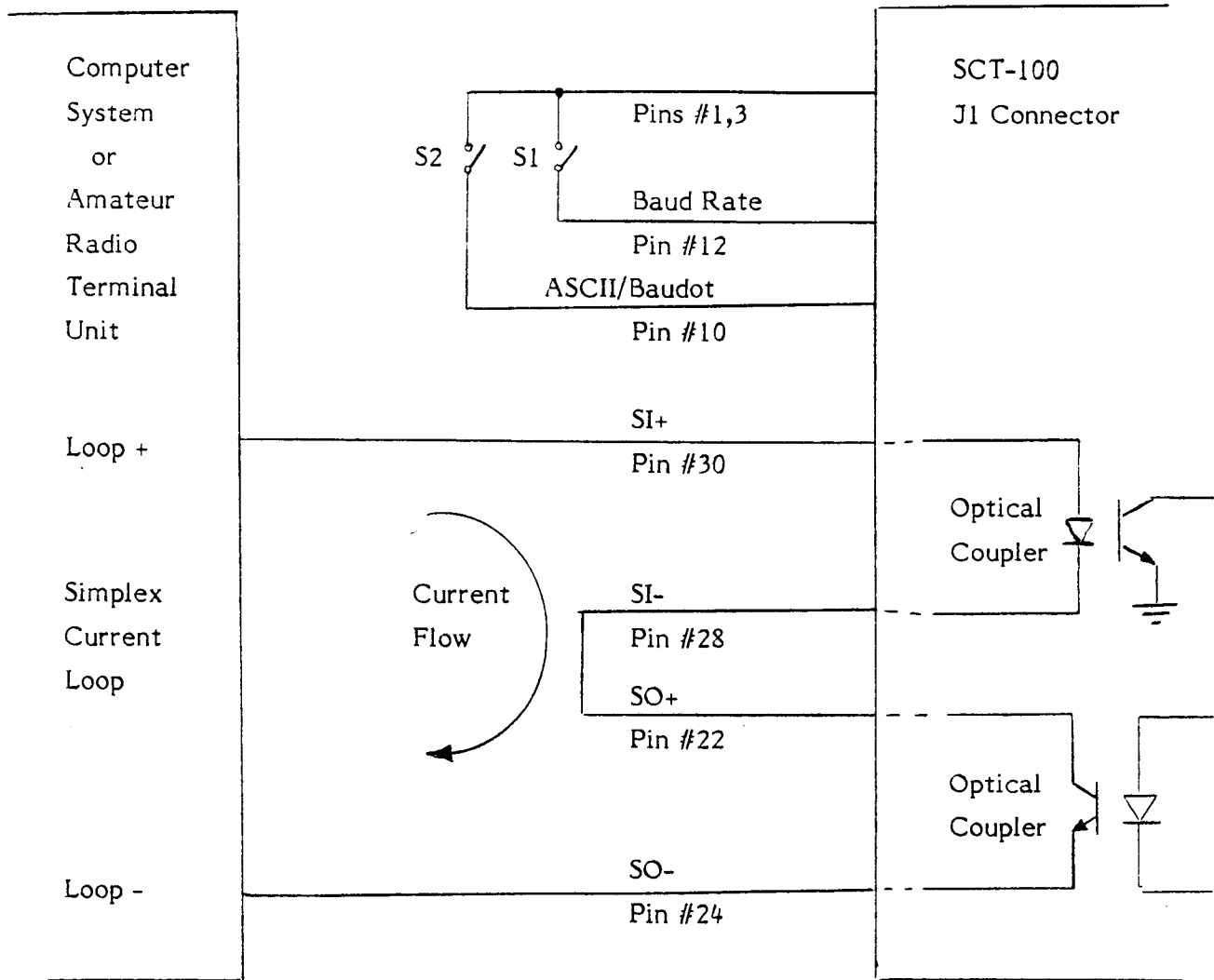

S1 Open = High Baud Rate (300 ASCII or 74.2 Baud Baudot)

S1 Closed = Low Baud Rate (110 Baud ASCII or 45.45 Baud Baudot)

S2 Open = ASCII Operation

S2 Closed = Baudot Operation

SIMPLEX CURRENT LOOP - 2 Wire Hook-up

Figure 4.5

4.5.2.3 Simplex Current Loop Connection (2 wire hook-up)

Refer to figure 4.5

The SCT100 may be used in a simplex current loop system by making the following connections:

- A Connect SI- (pin 23) to SO+ (pin 22)
- B Connect SI+ (pin 30) to the positive connection in the simplex current loop, i.e. current flows into SI+ (pin 30).
- C Connect SO- (pin 24) to the negative connection in the simplex current loop, i.e. current flows out of SO- (pin 24).

CAUTION: Maximum voltage = 180V - Maximum current = 70ma.

4.6 Initial Hook-up and Checkout (Local Mode)

The first check of the system is to configure the SCT-100 as a "TV Typewriter," i.e. a local terminal. This will allow the user to verify all of the SCT-100 functions prior to attaching his computer. To configure the SCT-100 as a local terminal the following must be done:

- A Attach a power supply as discussed in section 4.2. Check the power and verify that the supply is delivering +5V 5% to pad E4.
- B Attach the video monitor as discussed in section 4.3.
- C Attach the ASCII keyboard as discussed in section 4.4.
- D Connect the "RS 232 out" signal (J1 pin 16) to the "RS 232 in" signal (J1 pin 18).
- E Verify that steps A through D have been properly implemented.

The SCT-100 is now hooked up as a local terminal. The power may now be turned on. Simultaneously press the keyboard keys "CTRL" and "L". The cursor should now be in the upper left hand corner of the monitor screen. Depress keys on the keyboard. If the appropriate numbers/letters appear on the screen, go to section 5 for a detailed treatment of the special control characters of the SCT-100. If problems are encountered at this point, turn off the power and recheck the entire hook-up and check the SCT-100 for improper construction if your SCT-100 was purchased in kit form. Refer to section 4.8 for trouble shooting hints.

4.7 Hook-up and Checkout with a Mini/Micro Computer

After completing the checkout of the SCT-100 as described in section 4.6, it only remains to add the computer to the system. This section will discuss in detail a 300 Baud, ASCII, full Duplex hook-up to the computer.

NOTE: Refer to figures 4.2 through 4.4 for the various hook-up options.

The steps in making the hook-up are:

- A Attach the power supply as described in section 4.2
- B Attach the video monitor as described in section 4.3
- C Attach the ASCII keyboard as described in section 4.4
- D Connect the Duplex current loop to the computer as described in section 4.5.2.2
- E Leave open pins 10 and 12 on J1 for 300 Baud ASCII operation.
- F Verify that steps A through E have been properly implemented.

The SCT-100 is now hooked up as a terminal to your computer. The power may now be turned on. Simultaneously depress keyboard keys "CTRL" and "L". The screen should be cleared and the cursor in the upper left hand corner of the screen. Checkout may be completed by turning to section 5 for a discussion of the special control characters of the SCT-100.

If problems are encountered at this point, turn the power off and recheck the entire hook-up and check the SCT-100 for improper construction if your SCT-100 was purchased in kit form. Refer to section 4.8 for trouble shooting hints.

Component Side

Solder side

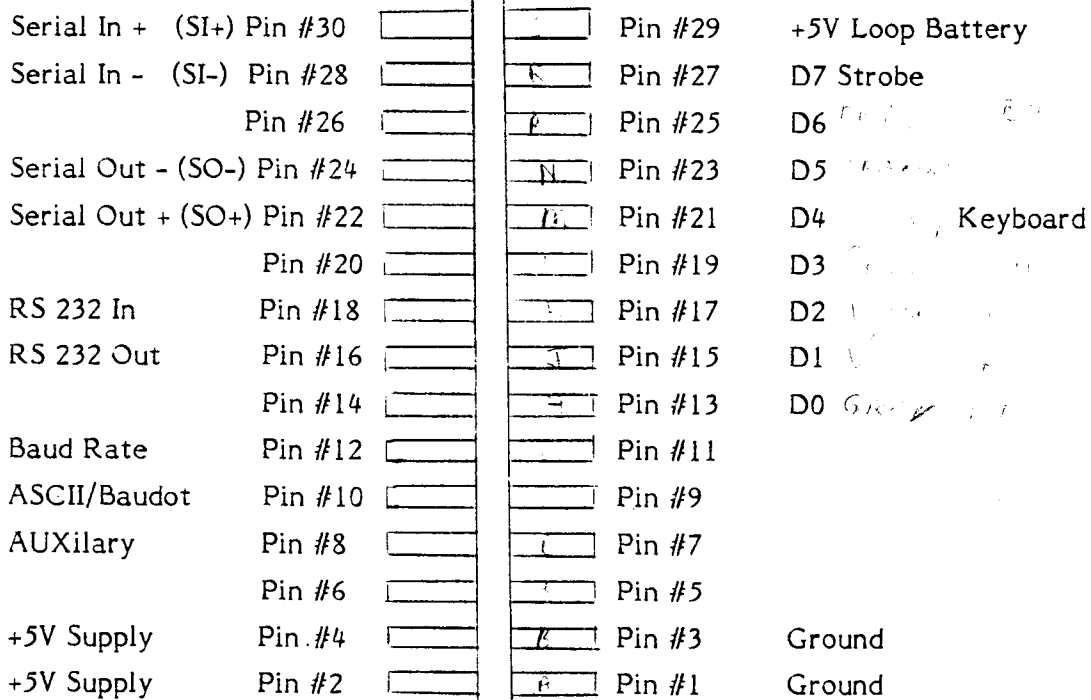

J1 CONNECTOR - PIN MAP

4.8 Trouble Shooting Guide

Fault/Symptom	Corrective Action
No cursor visible	<ul style="list-style-type: none">- Check SCT-100 power supply for +5V output- Physically inspect SCT-100 to video monitor for proper connection.- If still no cursor see warranty section
Cursor visible but does not index on key entry	<ul style="list-style-type: none">- Check SCT-100 to keyboard hook-up for correct connection.- Is keyboard +5V only? If not then external supplies required.- Is keyboard logic positive true logic including strobe? If not see assembly instructions, Section 2.- If problem persists see warranty section.
Screen does not clear on power-up	<ul style="list-style-type: none">- Increase value of C18 to 20 mfd.- If problem persists see warranty section.

For problems other than those discussed here it is advised that you follow the directions in the warranty section so as not to void the warranty.

4.9

LIMITED WARRANTY

KITS: Defective parts supplied by Xitex will be replaced free of charge if returned to the factory within ninety days of receipt. If the entire board is returned for repair within the warranty period, there will be a labor charge of \$25.00 per hour, with the defective parts replaced free.

THIS WARRANTY IS VOID IF THE KIT IS SOLDERED WITH CORROSIVE FLUX OR IF INTEGRATED CIRCUIT SOCKETS NOT SUPPLIED BY XITEX ARE USED IN THE ASSEMBLY OF THIS KIT.

ASSEMBLED UNITS All units assembled and tested by Xitex are warranted to be free from defects for ninety days from the time of shipment. If they are found to be defective within this period they may be returned to the factory for repair or replacement free of charge.

Any unit that has been damaged due to misuse, improper isolation, improper operation or modification may, at the option of Xitex, be repaired at the factory at a labor cost of \$25.00 per hour plus the cost of replacement parts.

This manual has been carefully checked for accuracy, but no warranty is made as to the correctness of this document or the suitability of this product for any purpose. No liability is assumed for any damages, consequential or otherwise, that result from the use or misuse of this product.

XITEX
P.O.Box #20887
Dallas, Texas 75220

5. OPERATING INSTRUCTIONS

5.1 INTRODUCTION

The SCT-100 has two modes of operation: ASCII or Baudot. In either mode an ASCII keyboard is used. The SCT-100, when strapped for either operating mode, automatically selects the proper serial I/O format, control, and editing features. This section outlines in detail the operating features for each mode.

5.2 ASCII OPERATION

5.2.1 CHARACTER SET

Connect the SCT-100 in the ASCII TV Typewriter configuration shown in the Installation and Checkout section 4. You are now ready to verify the printable character set shown in table 5.1.

αβγδεθιλμνπσφψωΩ⁰² 0123 ±÷=√/|↔+↓ Special Characters
!'"#\$%&'()*+,-./0123456789:;<=>? Numbers & Symbols
@ABCDEFGHIJKLMN⁰OPQRSTUVWXYZ[\]^_ Upper Case
`abcdefghijklmnopqrstuvwxyz{|}~ Lower Case

Printable ASCII Character Set
TABLE 5.1

The characters in Table 5.1 correspond to binary values 000 0000 (Hex 00) through 111 1111 (Hex 7F). this gives a total of 128 printable characters. Table 5.1 is arranged in order of increasing binary or Hex value reading left to right and top to bottom, i.e. α = Hex 00, ~ = Hex 7E. If you have a seven bit ASCII keyboard, Numbers and Symbols, Upper Case, and Lower Case characters may be seen by simply depressing the appropriate key. With a six bit keyboard the lower case characters cannot be generated.

Special characters require a multi-key entry sequence to be displayed. The sequence is initiated by a Down Shift 'DS'. The 'DS' is generated by entering a Hex 10. Different keyboards may generate the Hex 10 code with different combinations of keys. For example the 6-bit Cherry model B70 4753 generates Hex 10 when the control 'CNTL' is depressed and held while the 'P' key is depressed and released. This sequence is noted (CNTL then P) or "DS". the "DS" entry is not displayed but is recognised as a control input which defines the next entry (with Hex values 00 through 1F) as corresponding to special characters. Again, you may need to determine the key combinations on your keyboard which give you these Hex values

Example of Special Character Generation

<u>Key Entry</u>		<u>Display</u>
DS	(CNTL then P)	No Change
Hex 0B	(CNTL then K)	Σ
Hex 01	(CNTL then A)	A
Hex 0C	(CNTL then L)	Form Feed
DS	(CNTL then P)	No Change
Hex 1D	(CNTL then J)	→
DS	(CNTL then P)	No Change
Hex 16	(CNTL then V)	±

This example was done using a Cherry model B70-4753 keyboard and the "CNTL" key was simply depressed continuously.

5.2.2 EDIT AND CONTROL FUNCTIONS, GENERAL

A complete listing of all SCT-100 editing, control and cursor addressing functions including the 'DS' sequence just described is given in Table 5.2

OCTAL	HEX	CNTL	FUNCTION
004	04	D	Hom Home - moves cursor to upper left corner of screen
005	05	E	EOL Erase end of line - erases current line from right margin to current cursor position (1600mS max)
006	06	F	EOS Erase end of screen - erases lines from bottom of screen to, but not including, current line (400mS max)
010	08	H	BS Back space - move cursor left one column unless already in left most column.
011	09	I	HT Horizontal tab - moves cursor right one column unless already in right most column
012	0A	J	LF Line feed - moves cursor down one line, scrolls screen up if already on bottom line
013	0B	K	VT Vertical tab - moves cursor up one line, scrolls screen down if already on top line
014	0C	L	FF Form feed - clears screen and homes cursor (400mS)
015	0D	M	CR Carriage return - moves cursor to left margin
020	10	P	DS Down shift - sequence causes character following DS to be interpreted as printable rather than control. Required for lower 32 symbols (Greek and math), but may be used with any characters.
021	11	Q	DC1 Device control - sets AUX bit
023	13	S	DC3 Device control - clears AUX bit
033	1B	CSK	ESC Direct Cursor Addressing - ESC + ΔV ΔH adds ΔV modulo 16 to vertical cursor address, adds ΔH modulo 64 to horizontal cursor address ESC = $\Delta V \Delta H$ sets vertical cursor address to ΔV modulo 16, sets horizontal cursor address to ΔH modulo 64
177	7F	DEL	Delete - moves cursor left one column, unless cursor was already on leftmost column; erases new position

TABLE 5.2 ASCII CONTROL CHARACTERS

Table 5.2 shows the Octal and Hex value of the data word input to the SCT-100 serial input or keyboard in order to perform the desired control function. The 'CNTL' column shows the actual character key which, when depressed while simultaneously holding down the control 'CNTL' key, generates the correct control code.

The 'Function' column shows the mnemonic for the function performed and the function is then briefly described. In certain cases the time required to complete the particular function is shown in parentheses.

5.2.3. Control Functions

The control functions may be verified by proceeding as follows:

FF (Formfeed) - depress the CNTL key and while holding it down simultaneously depress the character key 'L.' This is a Formfeed function which immediately moves the cursor to the bottom line of the display and successively moves the cursor upward a line at a time clearing each line as it goes. The final cursor position is referred to as 'home' and corresponds to Line 0, Column 0 character position.

LF (Linefeed)-Depress CNTL and ' J', the cursor moves down one line in the same column location. If the cursor is on the bottom line the screen scrolls up.

CR (Carriage Return)- Depress 'CNTL' and 'M', the cursor moves to the left most column on the same line.

NOTE: Many keyboards may have single keys for 'LF' and 'CR' functions. Also, both 'LF' and 'CR' are required to advance the cursor to the beginning of the next line.

5.2.4. Cursor Positioning

The characters shown below when depressed simultaneously with the 'CNTL' key give the listed cursor positioning.

- H - Backspace - moves cursor left one column unless cursor is in left-most column. If so, no change.
- I - Horizontal tab - moves cursor right one column unless cursor is in right-most column. If so, no change.
- J - Linefeed - moves cursor down one line in the same column and scrolls the screen up if the cursor is already at the bottom.
- K - Vertical Tab - moves the cursor up one line. If the cursor is already on the top line the screen scrolls down.
- D - Home - moves the cursor to the home position (Line 0, Column 0), the upper left hand corner.

5.2.5. Direct Cursor Addressing

Two types of direct cursor addressing are available with the SCT-100 enabling the operator to move the cursor directly from any screen location to any new location directly.

ESC - Escape is the key used to initialize the SCT-100 for direct cursor addressing. If your keyboard does not have an 'ESC' key it may be necessary to determine the key sequence which gives hex code '1B'. This code is commonly generated by simultaneously depressing the 'CNTL' and 'Shift' key, then while holding them down depressing 'K'.

Relative Addressing - Following the "ESC" entry, a "+" entry establishes the relative addressing mode. Two additional key strokes are now required; ' ΔV ', and ' ΔH '.

ΔV = ASCII equivalent of the entered character added modulo 16 to the existing vertical cursor address.

ΔH = ASCII equivalent of the entered character added modulo 64 to the existing horizontal address.

Seven Bit Binary Equivalent	ASCII Character	Equiv. Disp. ΔV	ΔH	Seven Bit Binary Equivalent	ASCII Character	Equiv. Disp. ΔV	ΔH
100 0000	@	0	0	010 0000	blank	0	32
100 0001	A	1	1	010 0001	!	1	33
100 0010	B	2	2	010 0010	"	2	34
100 0011	C	3	3	010 0011	#	3	35
100 0100	D	4	4	010 0100	\$	4	36
100 0101	E	5	5	010 0101	%	5	37
100 0110	F	6	6	010 0110	&	6	38
100 0111	G	7	7	010 0111	'	7	39
100 1000	H	8	8	010 1000	(8	40
100 1001	I	9	9	010 1001)	9	41
100 1010	J	10	10	010 1010	*	10	42
100 1011	K	11	11	010 1011	+	11	43
100 1100	L	12	12	010 1100	,	12	44
100 1101	M	13	13	010 1101	-	13	45
100 1110	N	14	14	010 1110	.	14	46
100 1111	O	15	15	010 1111	/	15	47
101 0000	P	0	16	011 0000	0	0	48
101 0001	Q	1	17	011 0001	1	1	49
101 0010	R	2	18	011 0010	2	2	50
101 0011	S	3	19	011 0011	3	3	51
101 0100	T	4	20	011 0100	4	4	52
101 0101	U	5	21	011 0101	5	5	53
101 0110	V	6	22	011 0110	6	6	54
101 0111	W	7	23	011 0111	7	7	55
101 1000	X	8	24	011 1000	8	8	56
101 1001	Y	9	25	011 1001	9	9	57
101 1010	Z	10	26	011 1010	:	10	58
101 1011	[11	27	011 1011	;	11	59
101 1100	\	12	28	011 1100	<	12	60
101 1101]	13	29	011 1101	=	13	61
101 1110	↑	14	30	011 1110	>	14	62
101 1111	←	15	31	011 1111	?	15	63

ASCII EQUIVALENT VALUES FOR ΔV AND ΔH
TABLE 5.3

Example of keystroke sequence for relative addressing, ESC + D X. Upon completion of this four key sequence the cursor will be positioned at a new location. Assuming an initial cursor location = line 3, column 9, the new location is now line 3+4 (ASCII value of D mod 16 = 4) or line 7, column 9+24 (ASCII value of X mod 64 = 24) or column 33.

NOTE: no change will occur in the display until completion of the entire four key sequence for either relative or absolute addressing modes.

Absolute Addressing - This mode is identical to the relative addressing mode with the exception that the "=" key is used instead of the "+" key and the ΔV , ΔH entries are not added to the existing address, but are absolute address values.

Example of keystroke sequence for absolute addressing: $\underline{ESC} = \underline{\& 4}$ This sequence will move the cursor to line 6 (ASCII value of $\underline{\&} \bmod 16 = 6$), column 52 (ASCII value of $\underline{4} \bmod 64 = 52$) regardless of the previous cursor position.

5.2.6 Editing

The SCT-100 has several editing features which allow the operator to enter and then later modify the display contents. The functions are generated by depressing simultaneously "CNTL" and one of the keys discussed below.

E "EOL - Erase to End of Line - The cursor moves immediately to the right-most column, then sequentially moves left a column at a time erasing each location until reaching the original cursor location.

F "EOS" - Erase to End of Screen - The cursor moves immediately to the bottom of the display and then sequentially increments a line at a time upward to its original position erasing each line up to but not including the current line.

DEL or Rubout - This key does not require that the "CNTL" key be depressed. It moves the cursor back one space and erases the character in the new position. There is no change if the cursor is in the left-most column.

5.2.7 Auxiliary Device Control

This feature allows the AUX bit from the 3870 microcomputer on the SCT-100 to be set or cleared with the following keystroke sequences:

"CNTL" and "Q" (DC1) sets the AUX bit to +5V level

"CNTL" and "S" (DC3) clears the AUX bit to 0V level

The AUX bit may be used to control any other device in your system. Applications include magnetic cassette control, audible signals, character generator ROM control for modifying display font, etc.

5.2.8 Summary

In the previous operation description it is implied that the source of the control and edit features is an ASCII keyboard. However, in any system where the SCT100 is used as a terminal other than a TV Typewriter, the control and edit features may also be initiated from a computer or another terminal through the serial I/O channel.

5.3 BAUDOT OPERATION

5.3.1 Character Set

With the SCT-100 connected as described in the previous sections but strapped for Baudot operation (see installation and Checkout section) the character set shown in Table 5.4 may be observed.

A B C D E F G H I J K L M N O P Q R S T U V W X Y Z (letters)
- ? : * 3 \$ & # 8 () . , 9 0 1 4 ' 5 7 ; 2 / 6 " (figures)

Printable Baudot Character Set
Table 5.4

NOTE: In the Baudot mode the keyboard used is the same as for ASCII operation. Only the serial in and out ports change to the 5-bit Baudot code.

5.3.2 Control Functions

In Baudot mode only the carriage return "CR" and line feed "LF" control codes are used. One additional control character (ASCII code "Rubout") $7F_{16}$ or 177_8 generates a 'Letters' shift. This control allows the sender to initialize the receiver prior to sending code.

The 'Letters' and 'Figures' shift characters are generated automatically when the operator switches from a 'Letter' key entry to a 'Figure' and vice versa.

With the SCT-100 strapped for Baudot operation, keys corresponding to the 'Letters' and 'Figures' in table 5.4 generate an output. All other key entries are ignored.

6 THEORY OF OPERATION

6.1 INTRODUCTION

This section will provide a functional description of the SCT-100

Refer to Figure 6.1 SCT100 Block Diagram and Figure 6.2 SCT100 Schematic. The numbers corresponding to each device on the schematic may be found within each functional block on the Block Diagram.

6.2 3870

Referring to the Block Diagram, the MK3870 forms the heart of the SCT100 performing the following functions:

- Serial I/O formatting
- Control character decoding
- Keyboard interfacing
- Cursor control
- Scrolling address control

6.3 Address Timing Chain

Timing for the SCT-100 is derived from a crystal controlled TTL divider chain. The Character Generator ROM and Refresh RAM addresses, composite synch, 3870 clock and other control signals are derived from this timing chain.

6.4 Scrolling Adder

This function sums the vertical address from the timing chain and the scroll address from the 3870, generating the vertical address applied to the Refresh RAM. This configuration allows any line within the Refresh RAM to be displayed in any position on the CRT screen by merely changing the scroll address from the 3870.

6.5 Refresh RAM

Seven 21L02, 1K x 1024 static RAMS provide sufficient storage for a 16 line 64 character/line display. A character can only be written into the Refresh RAM when the Cursor Address equals the RAM address. The timing chain addresses each RAM location sequentially at a 60HZ rate providing a stable flicker free display.

6.6 Comparators

The Horizontal and Vertical Comparators provide a means to determine when the 3870 cursor addresses and the Refresh RAM addresses are identical.

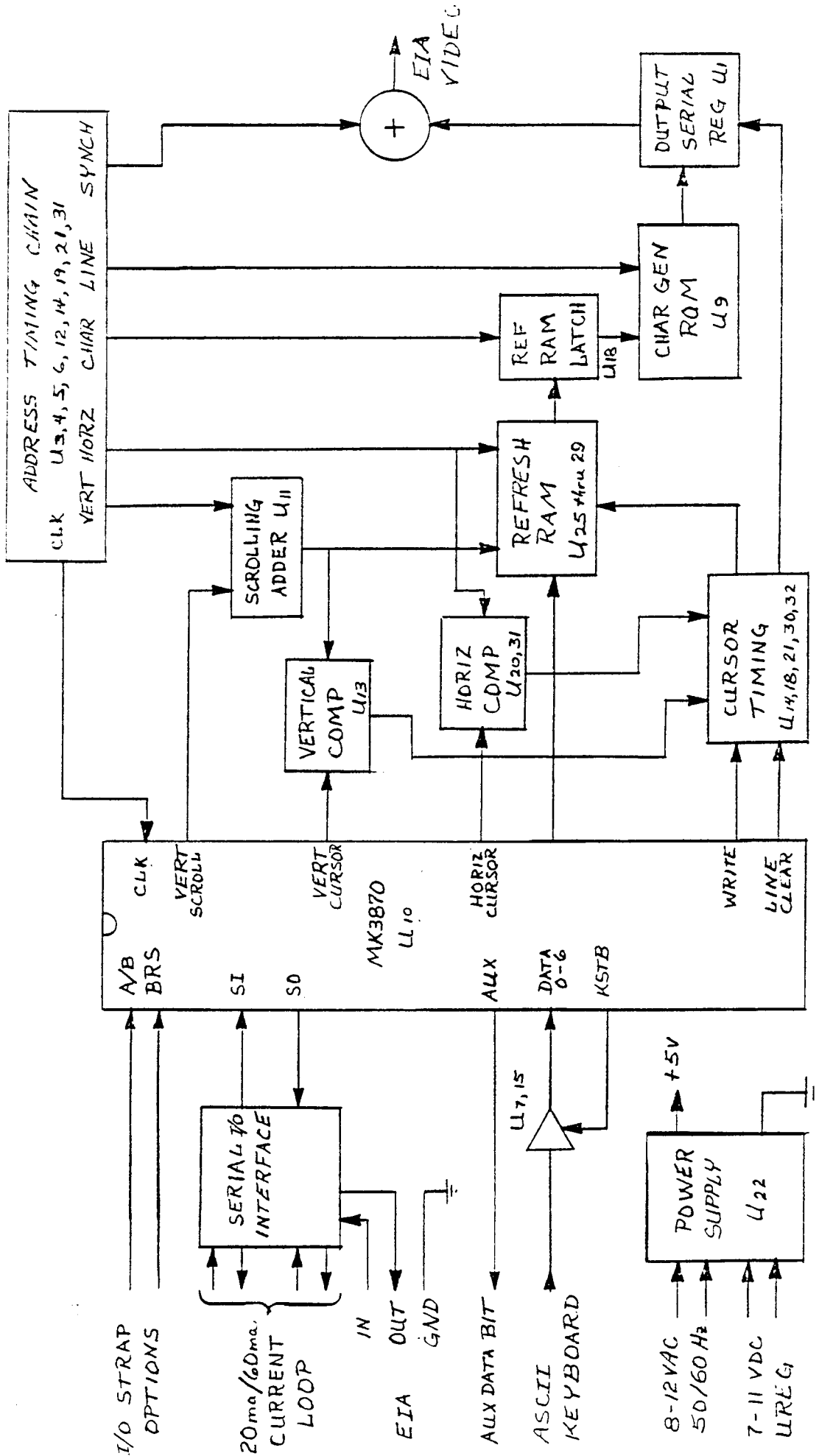

SCT - 100 BLOCK DIAGRAM

Figure 6.1

6.7 Cursor Timing

When a signal from the both comparators is present at the Cursor Timing inputs, the proper sequence is generated using the Write and Line Clear inputs to allow data to be written to the Refresh RAM. The Cursor Timing also derives a clock from the Address Timing Chain to drive the Output Serial Register.

6.8 Refresh RAM Latch

This latch performs the task of holding the character read from the Refresh RAM stable for an entire character read out time while the next location is being addressed in the RAM.

6.9 Character Generator ROM

This MK34000 series ROM accepts a 7-bit ASCII code input from the Refresh RAM latch and with the timing input from the Address Timing Chain outputs a five-bit word to the Output Serial Register.

6.10 Output Serial Register

This register accepts each five-bit data word from the character Generator ROM and in turn serializes the data for presentation to the Video-Synch-Summer.

The SCT-100 employs a Raster Scan technique with a 5 x 8 dot matrix for each character. One column space between characters and three line spaces between each row provide inter-character and inter-line spacing. The cursor appears as an underline in the space where the next printable character will be located.

6.11 Video-Synch-Summer

This circuit takes timing and video data from the Address Timing Chain and the Output Serial Register and combines them in the correct proportions to provide EIA (RS170) 1.5V p-p Composite Video out. This signal may be connected directly to a CRT Monitor as explained in the Installation and Checkout section (#4).

6.12 Serial I/O Interface

Serial data to and from the SCT-100 will usually be in one of three forms:

20 ma	full-duplex current loop
60 ma	simplex current loop
EIA	RS232 bipolar voltage interface

The Serial I/O Interface circuitry provides total ground isolation for the two current loop modes and converts all three formats to levels accepted by the 3870. For hook-up details refer to the Installation and Checkout section.

6.13 Keyboard Interface

This circuit is simply an array of tristate buffers used to properly synchronize the TTL compatible ASCII keyboard. Again refer to the Installation and Checkout section for keyboard details.

6.14 Power Supply

The SCT-100 provides an on-board supply which accepts several different inputs as outlined in the Installation and Checkout section. The supply provides sufficient power for all the circuitry on the SCT-100 and a keyboard with not more than 250 ma current drain.

6.15 I/O Strapping Options

Refer to the Installation and Checkout section for strapping option details.
The 3870 may be configured to handle four different serial I/O formats:

<u>ASCII</u>	Baudot
110 Baud	74.2 Baud
300 Baud	45.45 Baud

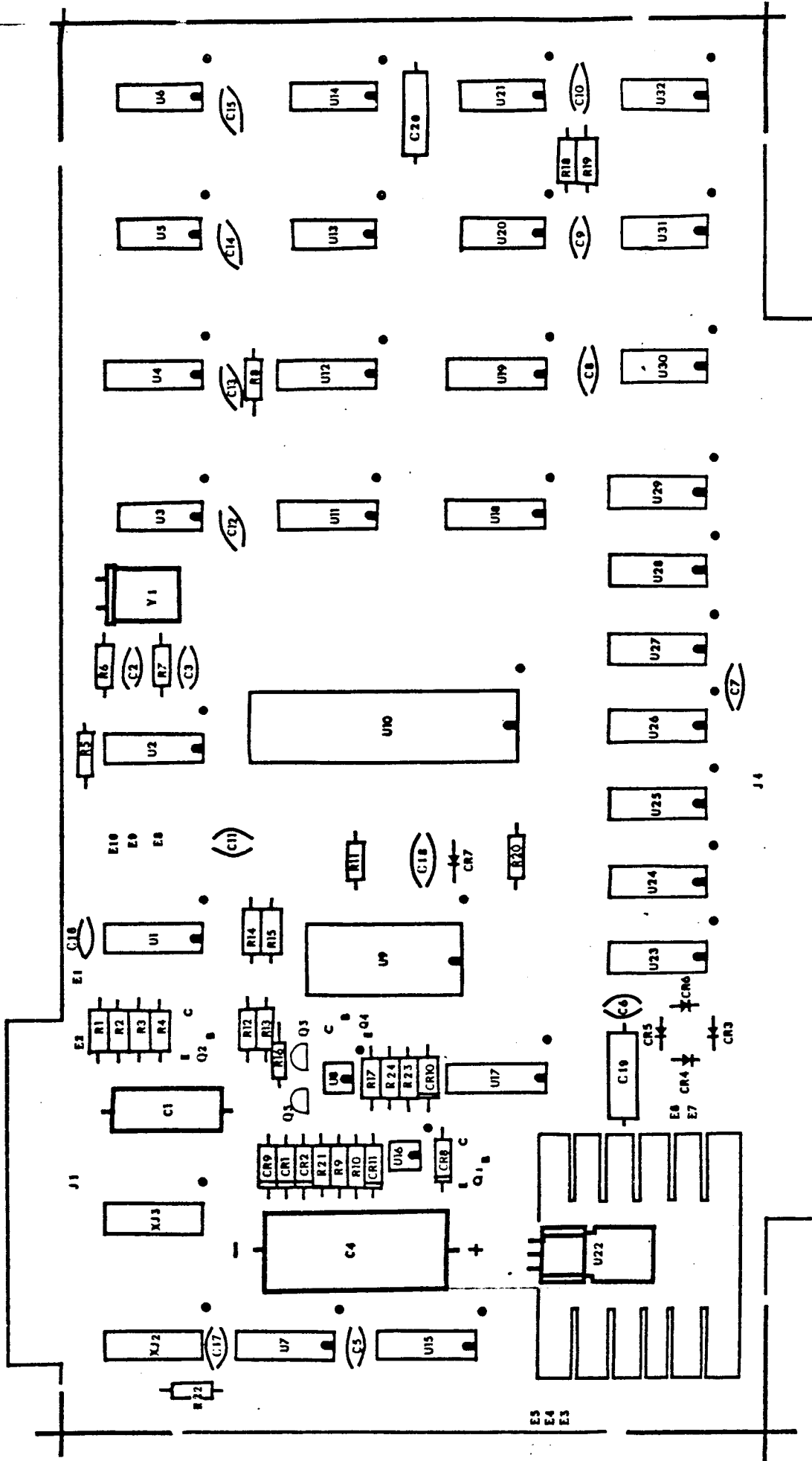

SCT-100 COMPONENT LAYOUT - VIEWED FROM COMPONENT SIDE

SCT-100

SCHEMATIC SWT 1-WZ

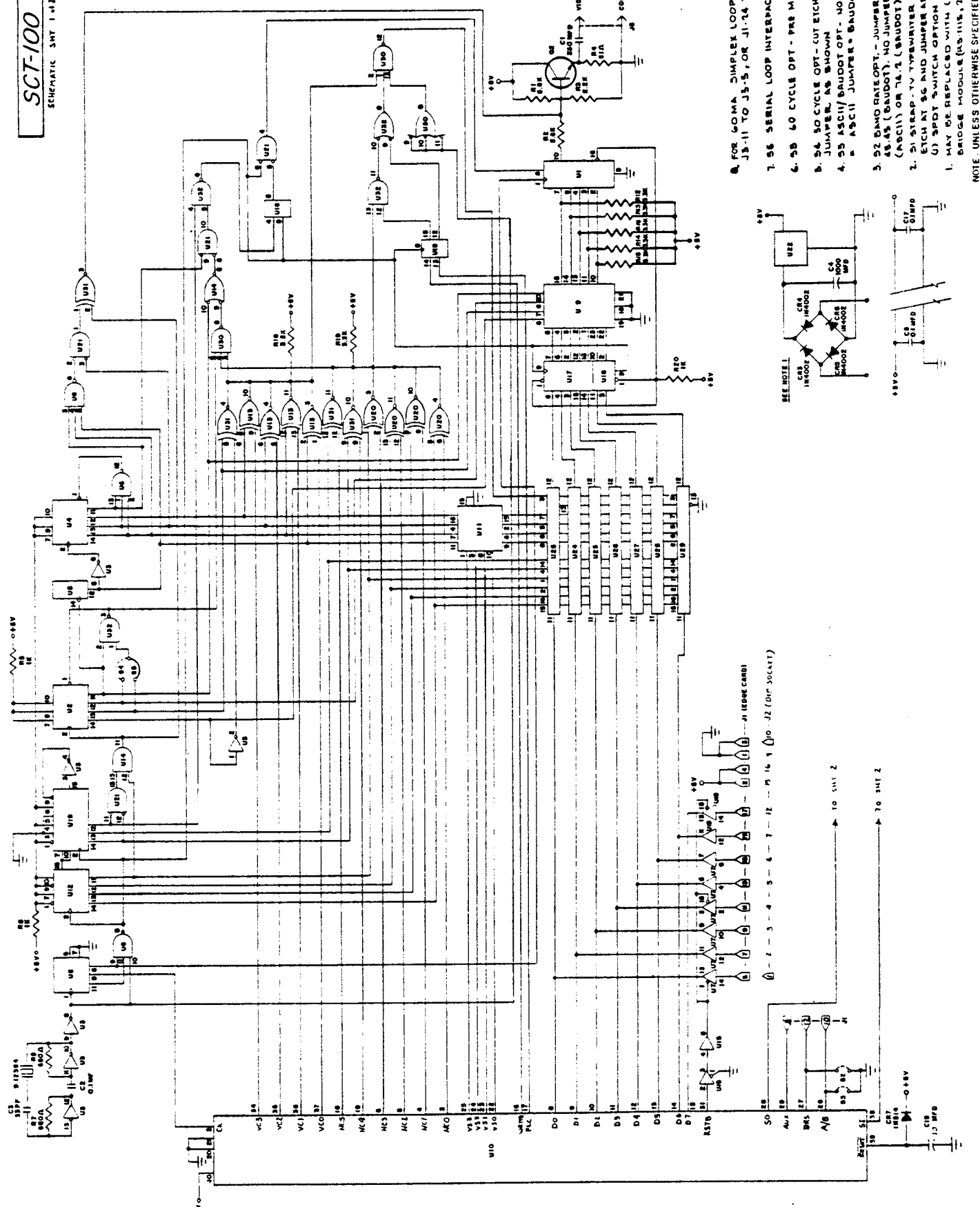

1. FOR GOMA DIMPLEX LOOP JUMPER, J3-11 TO J3-5, OR J1-14 TO J1-13
2. 56 SERIAL LOOP INTERFAC. - PRE MADE
3. 55 60 CYCLE OPT. - PRE MADE
4. 54 50 CYCLE OPT. - CUT ETCH AT 55 AND JUMPER AS SHOWN
5. 55 ASCII/BAUDOT OPT. - NO JUMPER (M15) = ASCII JUMPER = BAUDOT
6. 52 BAND RATE OPT. - JUMPER = 10 (ASCII) OR 48.45 (BAUDOT). NO JUMPER (M15) = 300 (ASCII) OR 74.1 (BAUDOT)
7. 51 STRAP - TV TYPEWRITER OPTION, CUT ETCH AT 56 AND JUMPER AS SHOWN OR U1 SWITCH OPTION
8. MAY BE REPLACED WITH (1) FULL BRIDGE MODULE (AS 115, 2, 8 50/50/50/50).

NOTE: UNLESS OTHERWISE SPECIFIED.

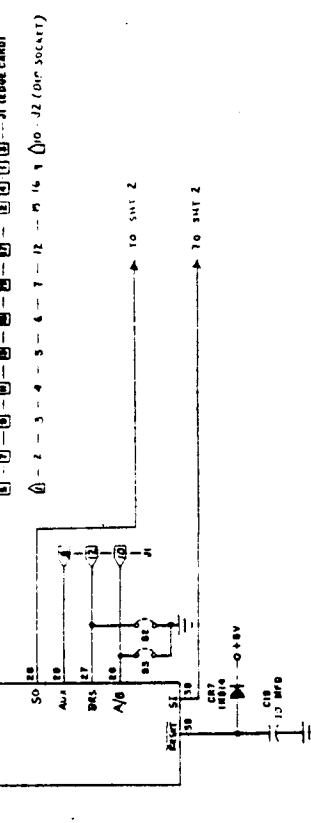
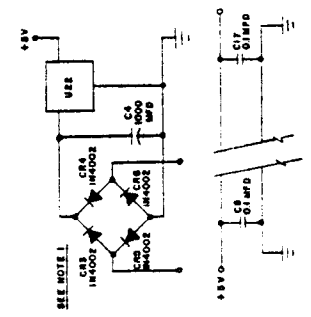

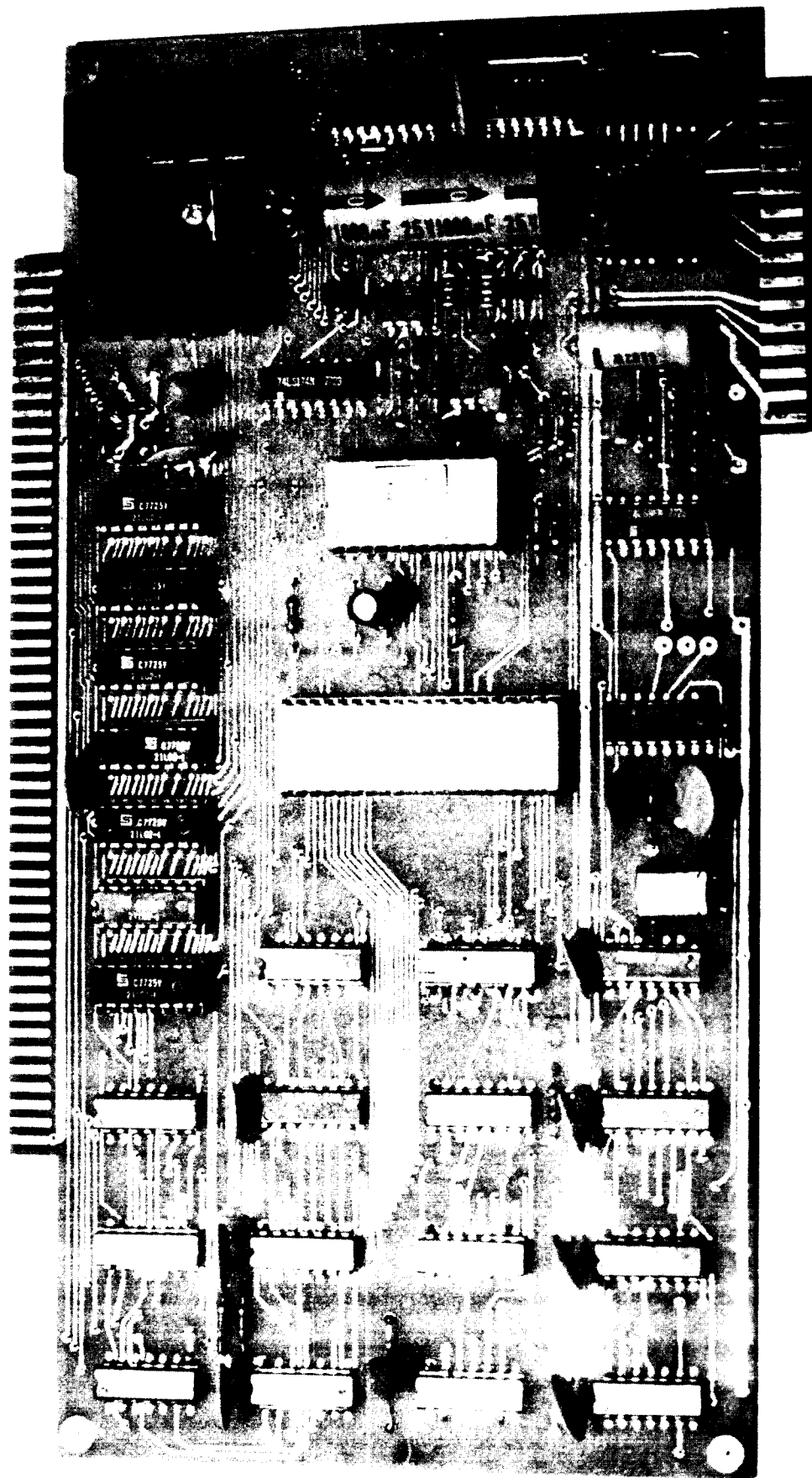

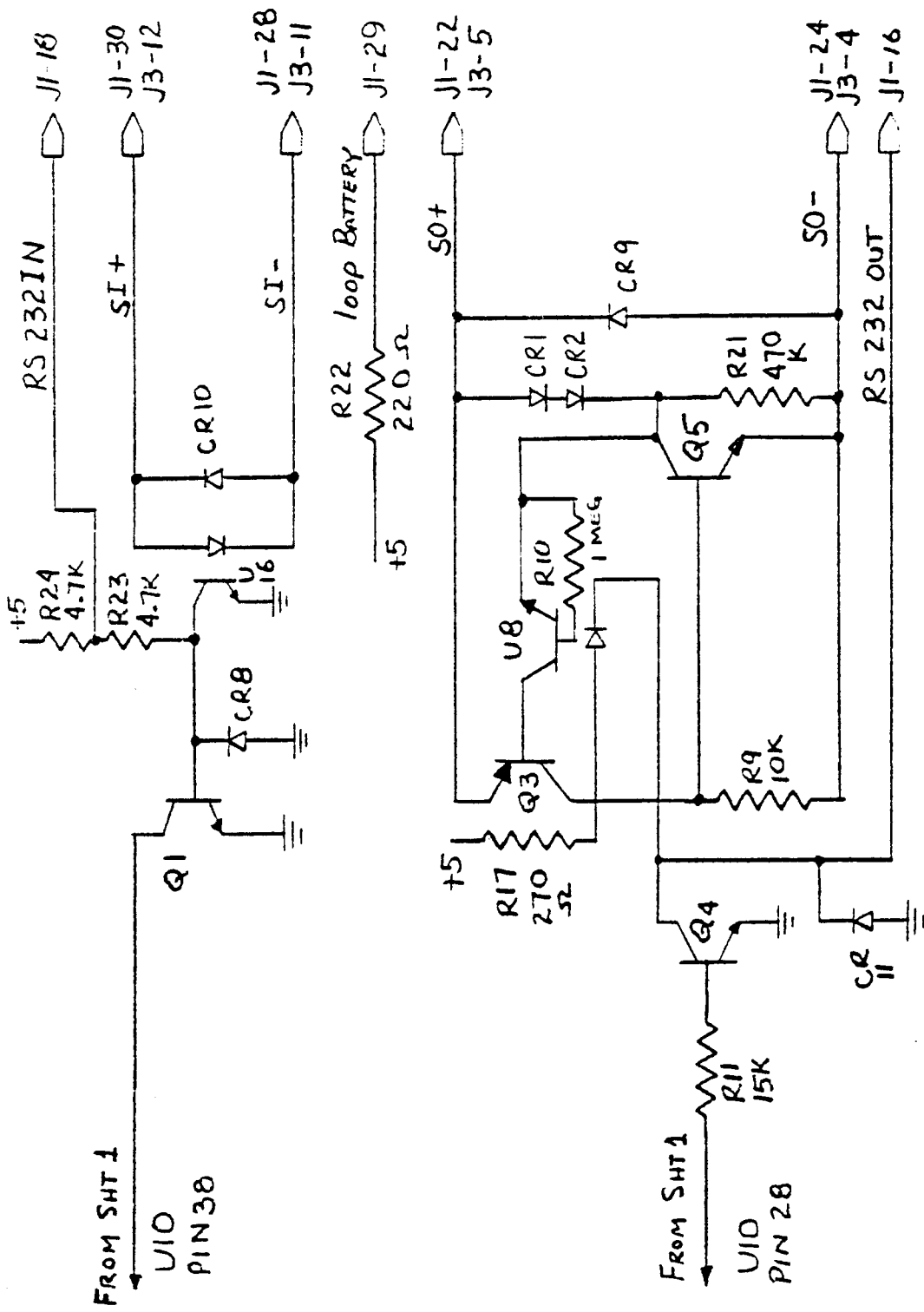

SCT-100 SCHEMATIC SHT 2 of 2

SCALE:	APPROVED BY:	DRAWN BY:
DATE:		REVISED:
DRAWING NUMBER		

IMPORTANT NOTICE

THE COMPONENT LAYOUT MAP IN THE ASSEMBLY AND OPERATIONS MANUAL PICTURES THE TRANSISTORS Q3 AND Q5 IN THE FOLLOWING ORIENTATION:

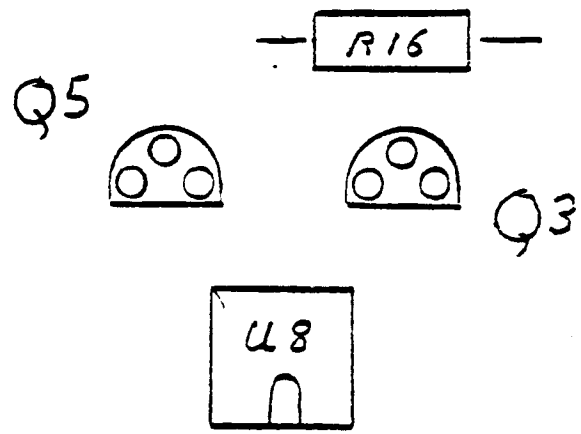

AS VARIOUS MANUFACTURERS OFFER THESE DEVICES WITH DIFFERING LEAD ARRANGEMENTS, DISREGARD THE DRAWING OF THE PHYSICAL SHAPE OF THE TRANSISTOR AND MOUNT THE DEVICE WITH REGARD TO ITS' LEAD FUNCTION ONLY, FOLLOWING THIS PATTERN:

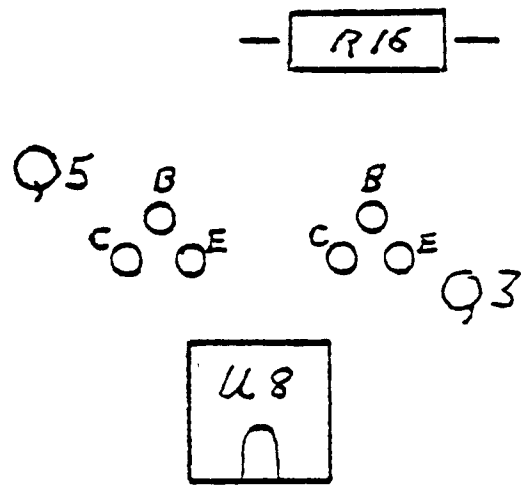

NOTE THAT THE OTHER TRANSISTOR LOCATIONS (THREE EACH, 2N3904) ARE ALREADY MARKED IN THIS FASHION. BE SURE WHICH LEAD IS WHICH BEFORE INSTALLING THE TRANSISTOR.