

HOW WE TEST HI-FI GEAR

75c ■ JUNE 1975

Radio-Electronics

THE MAGAZINE FOR NEW IDEAS IN ELECTRONICS

**NEW WAYS TO
USE YOUR SCOPE**
Special 4-Part Story

MAKE YOUR OWN
Reading Computer

VIDEO DISCS
Today And Tomorrow

**PHONO
CARTRIDGES
FOR CD-4**
See How They Work



A
GERNSBACK
PUBLICATION

PLUS

Equipment Reports
State-of-the-Art Solid-State
Jack Darr's Service Clinic
R-E's Replacement Transistor Directory

**DIGITAL
SCOPE
MEMORY**
Add It To
Your Scope Now

make your own reading computer

This device demonstrates how a computer recognizes characters. It can recognize and identify the numerals 1 through 9

by JOSEPH BRAUNBECK

THE ABILITY TO RECOGNIZE PATTERNS is one of the most impressive features of modern electronic computers. While their ancestors had to get every bit of data via punched card or tape, modern computer systems are able to read numbers and letters, printed or even handwritten. They can recognize star patterns for navigation or search acres of aerial reconnaissance film for the deadly patterns of tanks and rockets. How is this done? Usually a special peripheral unit, called a reading computer, is attached to the central processor of a large computing system. The following description shows how to build a demonstration model of such a reading computer. The relation of this model to a reading computer capable of reading about 3000 characters-per-second is about the same as that of a July-4-fireworks rocket to a Saturn V. Nevertheless this little box containing 17 toggle switches and 25 lamps gives a good idea of what is meant by the term "artificial intelligence."

A practical reading computer

To make this a simple device, I limited the number of patterns to be recognized to the shapes of the numerals 0, 1, 2, 3, 4, 5, 6, 7, 8 and 9.

There is a fairly large number of reading computers, so called "document readers," which are also specialized in reading numerals. For example, magnetic ink inscriptions on checks consist of numbers and a few special symbols only.

A reading computer for practical use has a rather complicated mechanism to transport the paper or film to be scanned towards and away from the scanner at high speed. The scanner locates the shapes to be recognized and converts them into electrical signals.

To keep the investment in money and work within the experimenter's reach, I omitted the mechanical transport as well as the scanner and prefer

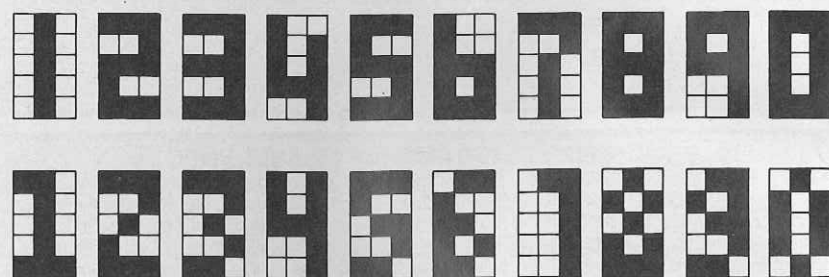
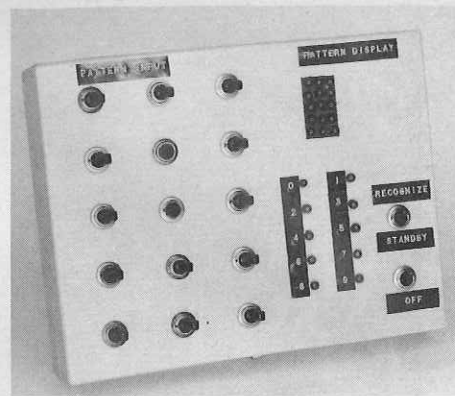

FIG. 1—A FEW RECOGNIZABLE NUMBERS that can be generated with a 15-dot matrix.

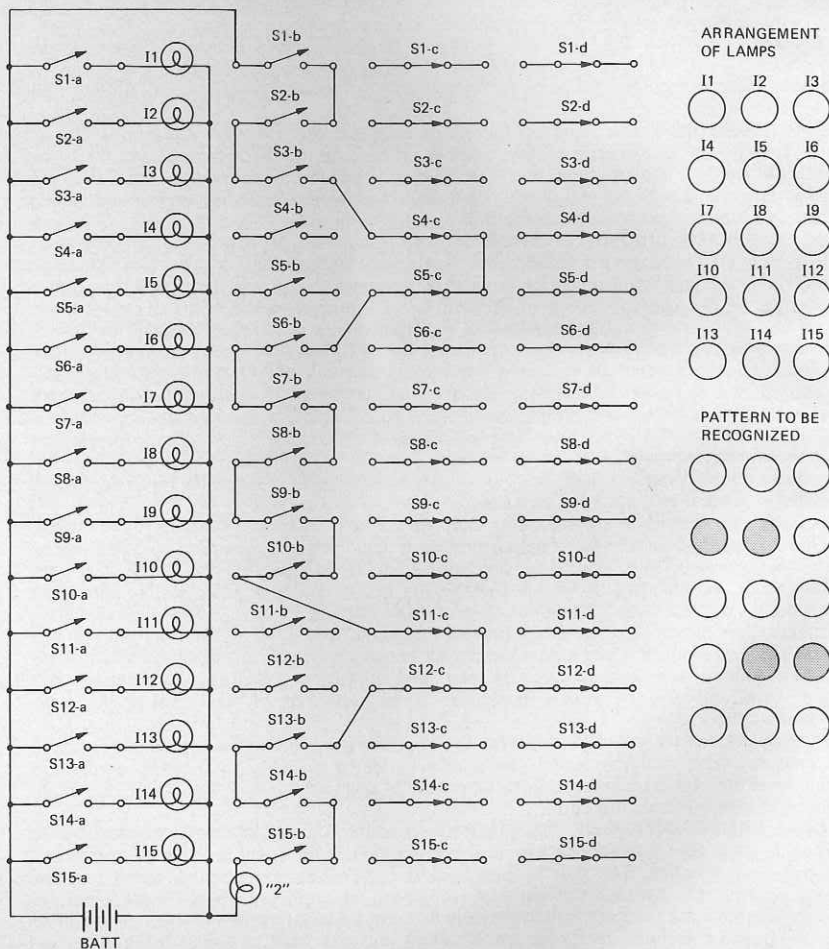
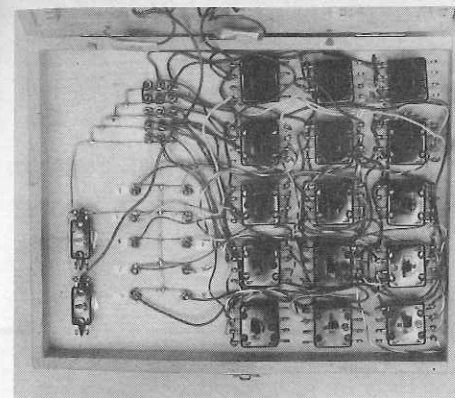

FIG. 2—THIS CIRCUIT WILL ONLY RECOGNIZE the pattern "2". It is an impractical circuit due to the number of switches that would be necessary to recognize all ten numbers.

PARTS LIST

- | | |
|---|--|
| S1 thru S15—4PDT toggle switches (see text) | 40mA (Hudson #1730, Sylvania #342, GE #1730D or equiv.—see text) |
| S16, S17—SPST toggle switches | |
| I1 thru I25 — sub-miniature lamps 6V, | BATT—6V, 800mA (see text) |



pattern input by hand.

In each reading computer, the pattern to be recognized is checked against a number of stored patterns. The stored pattern most similar to the incoming one, is then transmitted to the central processor unit of the computing system. Sometimes, for greater flexibility, the reading computer does not store the complete patterns, but only the characteristic features. We

will duplicate this part of the reading computer using the cheapest logic circuit elements available—switches.

As the average experimenter does not own a computer, our demonstration model has no computer output interface. If a pattern is recognized, the device shows its meaning by lighting one of ten lamps.

As mentioned earlier, pattern input is done by hand. That means that the pattern is composed of a number of lamps, that are switched on and off individually. Again, we have to think of our budget.

What is the minimum number of dots to form the shapes of the numeric characters 0-9? Experience shows, that you need at least 15 dots, 5 lines of 3 dots each. Believe it or not, you can compose 32,768 different patterns by choosing each of the dots to be black or white. Figure 1 shows a few numbers composed of 15 dots.

The circuit for realizing a 15 dot pattern input is shown in the left side of Fig. 2.

Fifteen switches are connected to 15 miniature lamps I1 through I15.

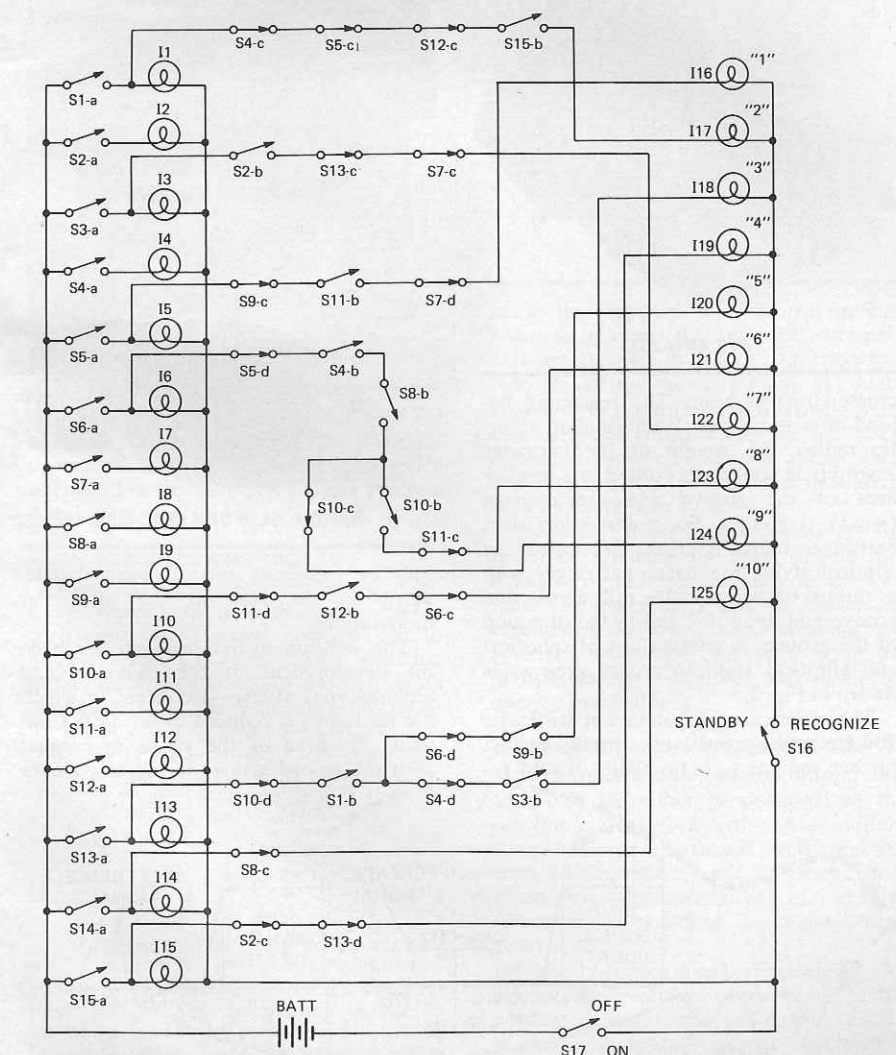

FIG. 3—PRACTICAL CIRCUIT that will recognize all ten numbers. This circuit reduces the number of switch contacts by recognizing only the essential features of numeric characters.

For the sake of convenience, the switches are arranged physically in the same manner as the miniature lamps. Now, by switching the lamps on and off, any of the 32,768 patterns can be realized and is promptly displayed by the lamps. But how can it be recognized? The answer is to use switches with more than one contact.

This device uses double-throw switches that close two contact pairs in one position, and two in the other position. So switch S1 has two contact pairs labelled S1-a and S1-b in the circuit that close when lamp I1 is switched on. And also has two contact pairs labelled S1-c and S1-d that close when lamp I1 is switched off. If such switches are used; there is a total of 60 contact pairs available. Figure 2 now shows a very straightforward approach to pattern recognition. While 15 contact pairs are used to display the pattern by means of lamps, there are 15 more contact pairs wired in such a manner, that the lamp labelled "2" is only energized if the display lamps I1 to I15 form the pattern of a "2" like that shown beside the circuit.

This straightforward approach has two disadvantages. The first is, that we have already used 30 of 60 contacts for recognizing only one shape. We would run into difficulties if we tried to wire all 10 numerals into the 15 switches. The second disadvantage is, that the device still is extremely stupid. If, for example, lamp I3 is extinguished, a human observer would still consider the pattern to be a "2". The machine, wired as in Fig. 2, would not be able to recognize it.

Both difficulties may be overcome if we do not store complete patterns but only essential features of numeric characters. For example, a "2" is sufficiently described if we say that lamps I4, I5 and I12 have to be switched off in any pattern in order to make it look like a "2", while I1 and I15 have to be switched on. Then, with only 60 contact pairs at our disposal, we cannot afford the luxury of using contact pairs only to switch display lamps. Furthermore, the wiring may take into account features common to two different characters. This too, saves contacts.

A circuit based on these principles is shown in Fig. 3. This device is able to recognize a variety of shapes by lighting the appropriate lamp. It does not use all the contact pairs that are available, so that there is enough room left to incorporate additional ideas.

Beside the on/off switch, there is another one labelled STANDBY/RECOGNIZE. This switch, which simply switches the bank of output lamps, adds much to the impressive performance.

(continued on page 78)

READING COMPUTER
(continued from page 45)

ance of the device. The 15-dot pattern is composed with the switch in the **STANDBY** position. Then the switch position is changed to **RECOGNIZE**, and on this command the output lamp lights up. Sometimes there are ambiguous patterns, which might be for example either a defective "2" or an incomplete "3". In this case, the output lamps labelled "2" and "3" will light up simultaneously. Most of these ambiguities, however, appear so also to the human eye.

As this is a digital circuit, the question of voltage ratings and power consumption is of secondary importance. The lamps may be any voltage or power, provided they do not impose excessive load on the switches. The battery, which may be replaced by a suitable transformer, has to be capable of bearing the full load of 15 display lamps and at least two output lamps. If it is desired, display and output lamps may be replaced by neon lamps to conserve power. However, the suitable supply voltage for neon lamps is 75-80 volts AC or 105-125 volts DC. Therefore, a suitable supply must be used.

Construction

The reading computer was built into a wooden case originally designed for 2 by 2 inch color slides. The case contains four flashlight cells in its lower compartment for power. Pattern input and other switches, pattern display lamps and output lamps, are all mounted on the lid of the case. The result is a very handy device suitable to be taken along to lectures, demonstrations, science fairs etc. However, any case that is large enough to accommodate all the components and a power supply can be used.

Switches S1 through S15 are 4PST types with two contact pairs open and two contact pairs closed. A schematic diagram of these switches is shown in Fig. 4-a. However, these switches may

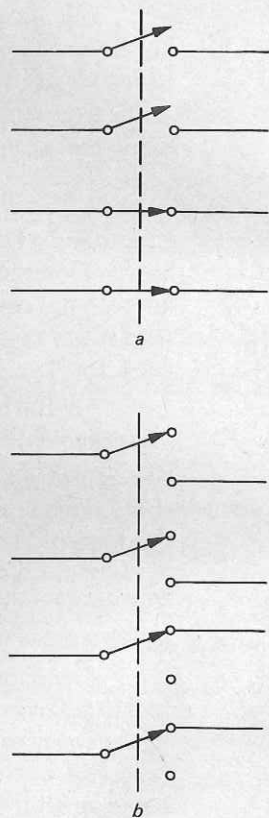

FIG. 4—ORIGINAL SWITCHES used for S1 through S15 were 4PST types with two contact pairs open and two contact pairs closed and are shown in a. In their place, 4PDT switches can be used if they are wired as shown in b.

be difficult to obtain. In their place, 4PDT switches can be used if they are connected as shown in Fig. 4-b. Though this device is extremely simple, it should provide many hours of entertainment in construction and use. **R-E**

IN THIS ISSUE
Radio-Electronics tests hi-fi equipment. Don't miss the introductory article describing how the tests will be done.

INTERNATIONAL FM 2400CH FREQUENCY METER for testing mobile transmitters and receivers

- Tests Predetermined Frequencies 25 to 1000 MHz
- Extended Range Covers 950 MHz Band
- Pin Diode Attenuator for Full Range Coverage as Signal Generator
- Measures FM Deviation



The **FM-2400CH** provides an accurate frequency standard for testing and adjustment of mobile transmitters and receivers at predetermined frequencies.

The FM-2400CH with its extended MHz. The range covers 25 to 1000 frequencies can be those of the radio frequency channels of operation and/or the intermediate frequencies of the receiver between 5 MHz and 40 MHz.

Frequency Stability: $\pm .0005\%$ from $+50^\circ$ to $+104^\circ\text{F}$.
Frequency stability with built-in thermometer and temperature corrected charts: $\pm .00025\%$ from $+25^\circ$ to $+125^\circ$ (.000125% special 450 MHz crystals available).

Self-contained in small portable case. Complete solid state circuitry. Rechargeable batteries.

- FM-2400CH** (meter only) \$595.00
- RF crystals** (with temperature correction) ... 24.00 ea.
- RF crystals** (less temperature correction) 18.00 ea.
- IF crystals** catalog price

Write for catalog!



Circle 25 on reader service card

equipment reports

Weston Model 670 In-Circuit Tester

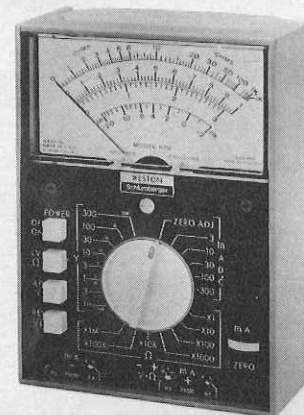

Circle 106 on reader service card

THE "TYPICAL" FET VOM CAN DO TRICKS that were unbelievable only a few years ago. Now, by combining linear IC technology and the FET VOM, they can work wonders. The Weston Model 670 In-Circuit Tester FET VOM is a good example of this new generation.

The model 670 is a portable, self-contained analog multimeter, powered from either 115 or 230 volts AC, at 60 Hz. It reads DC voltages on 8 ranges, from 0.1 volt to 300 volts, full-scale. Polarity is automatic; the meter reads upscale at all times and it displays the polarity on LED's. The AC voltage readings are read on the same scales, as is the current. These all use the handy "1-3" calibration, which makes them easier to read.

The ohmmeter section has both standard and low-voltage functions. On the standard ranges, 1.5 volts appears across the prods. On the low-voltage ohms setting, only 85 millivolts; this will not turn on transistor junctions.

Conventional DC current readings are made in the usual way, from 3.0 to 300 mA, full-scale. Normally, the circuit must be opened to make a current measurement. This is called the "two-terminal" current reading. Now, we get to the really novel feature of the Model 670. With it, you can read DC current in any circuit, on the same ranges, but *without* opening the circuit. No unsoldering of wires or cutting of PC board conductors! Current readings are thus made just as easy as DC voltage readings were; just a quick jab of the test probes.

In operation, it's simple. The circuit itself isn't. The basic metering circuit uses an FET op-amp that feeds a bridge, and the meter itself. A precision resistor

network determines the voltage applied to the op-amp, by the setting of the range switch. For two-terminal current readings, the op-amp monitors the voltage drop across the precision shunts, and this is read out as current values. The circuit must be opened.

To use the four-terminal method, two special probes are plugged in. Although they look like ordinary probes, they're not. Each one has two leads, and special concentric probe tips. These have a sharp, spring-loaded inner tip and an

(continued on page 88)

Retrieve Fading Color... And Save Money, Too with Perma Power Color-Brite



Save \$4.65 when you buy a four-pack of Model C-511 Color-Brites. And get a magnetic telescoping retriever free!

Ever dropped a nut or screw and had it bounce away from you, out of reach? With this magnetic telescoping retriever, it's easy pickings! The 5" long retriever clips to your pocket, so it's handy whenever you need to retrieve a part as far as 19 inches away.

It's just as easy to retrieve sharpness, contrast and fading color! Install a Perma Power Color-Brite . . . for immediate TV picture improvement and certain customer satisfaction. Model C-511 is the one you need for the prevalent rectangular picture tubes. These Color Brites usually sell for \$6.15 each, but for a limited time you can get a four-pack for just \$19.95. That's a \$4.65 savings, and the retriever is our gift. But supplies are limited, so see your distributor *today*.

Perma Power

Chamberlain Manufacturing Corporation
Perma Power Division
5740 North Tripp Avenue, Chicago, Illinois 60646
Telephone (312) 539-7171

Circle 26 on reader service card